

Ready, set, go.



Lenze is a key driver of Industry 4.0 – and your machine as well.

Lenze is a key driver of Industry 4.0 for a long time now. Thanks to open standards and interfaces, we enable an outstanding interplay of machine and machine modules

beyond the boundaries of your system, as well as supplying intelligent products that make decentralised processing of information possible for more efficiency and flexibility.

If you nod in agreement here ...

- You are looking for an easy solution that can be integrated functionally into your machine?
- You want to save time and costs?
- You are averse to long-drawn-out work to rectify defects and problems?
- You expect speed and uncomplicated delivery?
- You prefer a streamlined process for the creation of your machine?
- You have to meet all the requirements relating to the energy efficiency class of your machine?
- You want to use your solution worldwide?

... then Lenze Smart Products are exactly what you are looking for.

Profit from drive solutions that have been tried and tested thousands of times in horizontal materials-handling systems. In the form of ready-made modules that are tailored to your tasks exactly.

- For chain conveyors
- For roller conveyors
- Inline and Outline versions
- Up to 5,200 kg

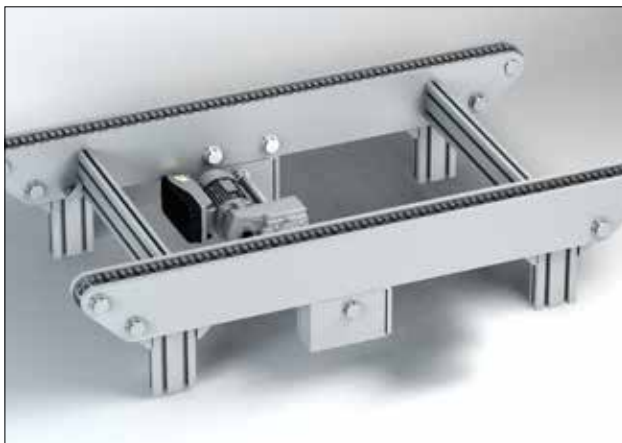

Example: Chain Conveyor Inline



Example: Roller Conveyor Outline

You have the choice – We have the solution.

1. Choose the conveyor system

Conveying speed of 0.1 to 0.5 m/s with a throughput rate of 300 units per hour and universal mounting position

Chain Conveyor

Roller Conveyor

2. Choose the version

Outline

Built-on version for easy mounting
and maintenance concept

Inline

Integrated into the machine frame as a low-cost
solution with minimal interfering contours

3. Choose the payload

up to 1,300 kg up to 2,000 kg up to 2,600 kg up to 4,000 kg up to 5,200 kg

... and that's it

An overview of the Lenze Smart Products.

	Chain Conveyor Inline (CCI)	Chain Conveyor Outline (CCO)		Roller Conveyor Inline (ROI)	Roller Conveyor Outline (RCO)
up to 1,300 kg	Lenze Smart Product CCI-1300	Lenze Smart Product CCO-1300	up to 2,000 kg	Lenze Smart Product RCI-2000	Lenze Smart Product RCO-2000
up to 2,600 kg	Lenze Smart Product CCI-2600	Lenze Smart Product CCO-2600	up to 4,000 kg	Lenze Smart Product RCI-4000	Lenze Smart Product RCO-4000
up to 4,000 kg	Lenze Smart Product CCI-4000	Lenze Smart Product CCO-4000	up to 5,200 kg	Lenze Smart Product RCI-5200	Lenze Smart Product RCO-5200
up to 5,200 kg	Lenze Smart Product CCI-5200	Lenze Smart Product CCO-5200			

Your benefits at a glance.

Simple engineering

- Construction plan with complete, coordinated information
- Optimised functions in accordance with applicable industrial standards
- Drive function optimised for greater energy efficiency, precisely tailored to meet current and future requirements
- Easy integration into the tried-and-tested safety concept with two mains contactors
- Wide mains voltage range for use worldwide

Easy commissioning

- Integrated motor and equipment contactor without complicated wiring
- Integrated brake resistor without complicated wiring
- Connection to mains supply without tools
- Connection and parameterisation with the housing closed
- Standardised control inputs

Long service life

- Design process is based on many years of experience in the area of materials-handling systems and leads to robust and long-lasting solutions
- Low-wear brake control at a standstill
- Versions for optimum maintenance options and minimal interfering contours

Lenze Smart Products – Everything you need.

You have found your Lenze Smart Products pretty quickly. Now, all you have to do is continue with this product name.



All information and data are available on our website for you to download.

Product information

- Key data
- Mounting dimensions
- Electrical connection plan

Engineering data

- CAD drawing
- E-PLAN macros
- Basics of the design
- Mounting instructions

Engineering tools

- App
- PC connection