

Automation systems

Drive solutions

Controls

Inverters

Motors

Gearboxes



Engineering Tools

Motors: MCS synchronous servo motors, MCA asynchronous servo motors

Gearboxes: MPR/MPG planetary gearboxes

Contents of the L-force catalogue

About Lenze		Lenze makes many things easy for you. A matter of principle: the right products for every application. L-force product portfolio		
Automation systems		Controller-based Automation	1.1	
		Drive-based automation	1.2	
Drive solutions		HighLine tasks	2.1	
		StateLine tasks	2.2	
		Baseline tasks	2.3	
Controls	Cabinet Controller	Controller 3200 C	3.1	
		Controller c300	3.2	
	Panel Controller	Controller p500	3.3	
		Controller p300	3.4	
		I/O system 1000	3.5	
		Monitor Panel	3.6	
Inverters	Decentralised	Inverter Drives 8400 protec	4.1	
		Inverter Drives 8400 motec	4.2	
	Cabinet	Servo Drives 9400 HighLine	4.4	
		Inverter Drives 8400 TopLine	4.5	
		Servo Inverters i700	4.6	
		Inverter Drives 8400 HighLine	4.7	
		Inverter Drives 8400 StateLine	4.8	
		Inverter Drives 8400 Baseline	4.10	
	Motors	Servo motors	MCS synchronous servo motors	5.1
			MD□KS synchronous servo motors	5.2
MQA asynchronous servo motors			5.3	
MCA asynchronous servo motors			5.4	
Three-phase AC motors		MF three-phase AC motors	5.5	
		MH three-phase AC motors	5.6	
		MD three-phase AC motors	5.7	
		m300 Lenze Smart Motor	5.8	
		MD/MH basic three-phase AC motors	5.9	
Gearboxes	Axial gearbox	g700-P planetary gearbox	6.1	
		MPR/MPG planetary gearboxes	6.2	
		g500-H helical gearbox	6.3	
		GST helical gearboxes	6.4	
		g500-S shaft-mounted helical gearbox	6.5	
		GFL shaft-mounted helical gearboxes	6.6	
	Right-angle gearbox	g500-B bevel gearbox	6.7	
		GKR bevel gearboxes	6.8	
		GKS helical-bevel gearboxes	6.9	
		GSS helical-worm gearboxes	6.10	
	Motor data	Assignment see above	6.11	
Engineering Tools		Navigator	7.1	
		Drive Solution Designer	7.2	
		Drive Solution Catalogue	7.3	
		Engineer	7.4	
		PLC Designer	7.5	
		VisiWinNET®	7.6	
		EASY Starter	7.7	

 Selected portfolio
 Additional portfolio

Lenze makes many things easy for you.

With our motivated and committed approach, we work together with you to create the best possible solution and set your ideas in motion - whether you are looking to optimise an existing machine or develop a new one. We always strive to make things easy and seek perfection therein. This is anchored in our thinking, in our services and in every detail of our products. It's as easy as that!

1

Developing ideas

Are you looking to build the best machine possible and already have some initial ideas? Then get these down on paper together with us, starting with small innovative details and stretching all the way to completely new machines. Working together, we will develop an intelligent and sustainable concept that is perfectly aligned with your specific requirements.

2

Drafting concepts

We see welcome challenges in your machine tasks, supporting you with our comprehensive expertise and providing valuable impetus for your innovations. We take a holistic view of the individual motion and control functions here and draw up consistent, end-to-end drive and automation solutions for you - keeping everything as easy as possible and as extensive as necessary.

3

Implementing solutions

Our easy formula for satisfied customers is to establish an active partnership with fast decision-making processes and an individually tailored offer. We have been using this simple principle to meet the ever more specialised customer requirements in the field of mechanical engineering for many years.

4

Manufacturing machines

Functional diversity in perfect harmony: as one of the few full-range providers in the market, we can provide you with precisely those products that you actually need for any machine task – no more and no less. Our L-force product portfolio, a consistent platform for implementing drive and automation tasks, is invaluable in this regard.

5

Ensuring productivity

Productivity, reliability and new performance peaks on a daily basis – these are our key success factors for your machine. After delivery, we offer you cleverly devised service concepts to ensure continued safe operation. The primary focus here is on technical support, based on the excellent application expertise of our highly-skilled and knowledgeable after-sales team.

A matter of principle: the right products for every application.

Lenze's extensive L-force product portfolio follows a very simple principle. The functions of our finely scaled products are assigned to the three lines Base-Line, State-Line or High-Line.

But what does this mean for you? It allows you to quickly recognise which products represent the best solution for your own specific requirements.

Powerful products with a major impact:

- Easy handling
- High quality and durability
- Reliable technologies in tune with the latest developments

Lenze products undergo the most stringent testing in our own laboratory. This allows us to ensure that you will receive consistently high quality and a long service life. In addition to this, five logistics centres ensure that the Lenze products you select are available for quick delivery anywhere across the globe. It's as easy as that!

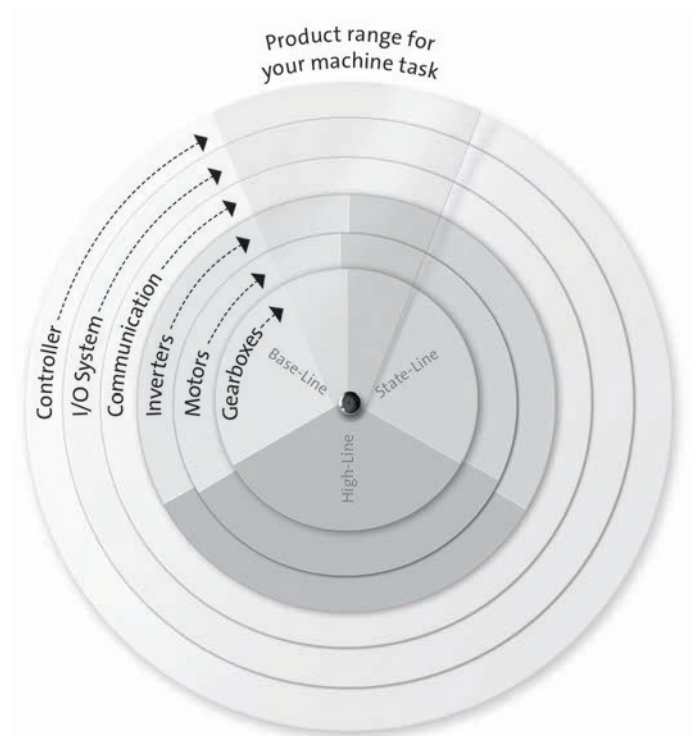

L-force product portfolio

Controls

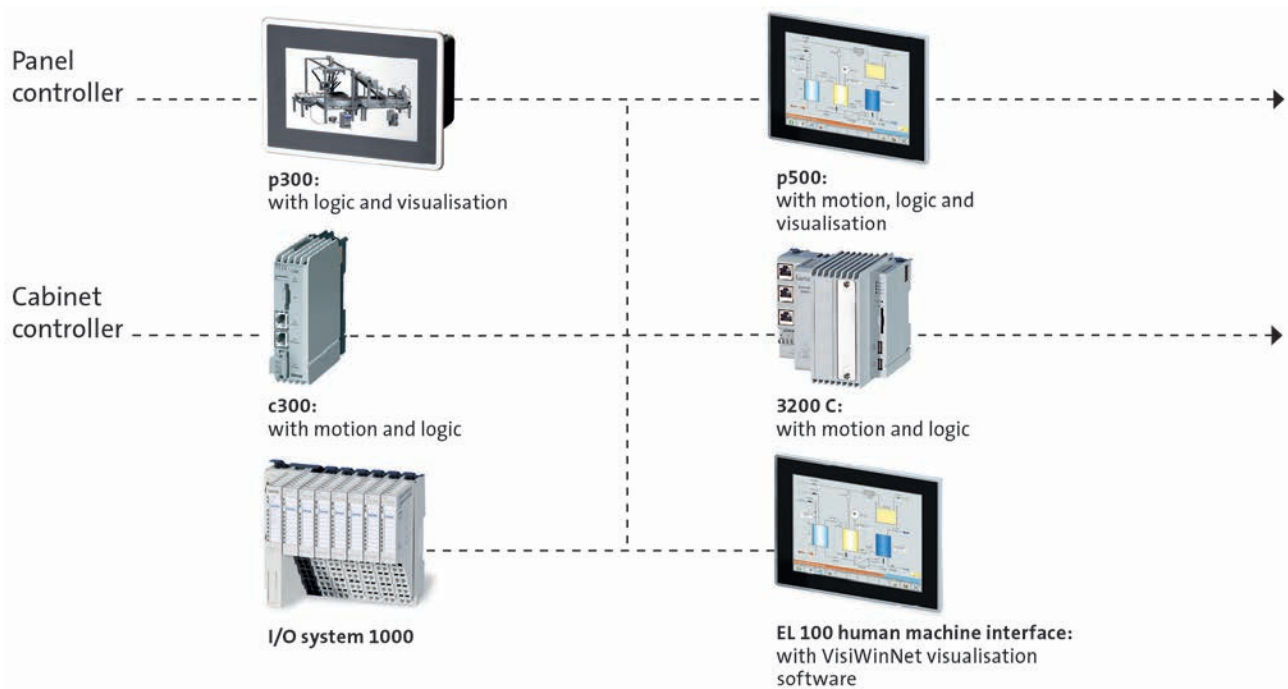

Engineering Tools

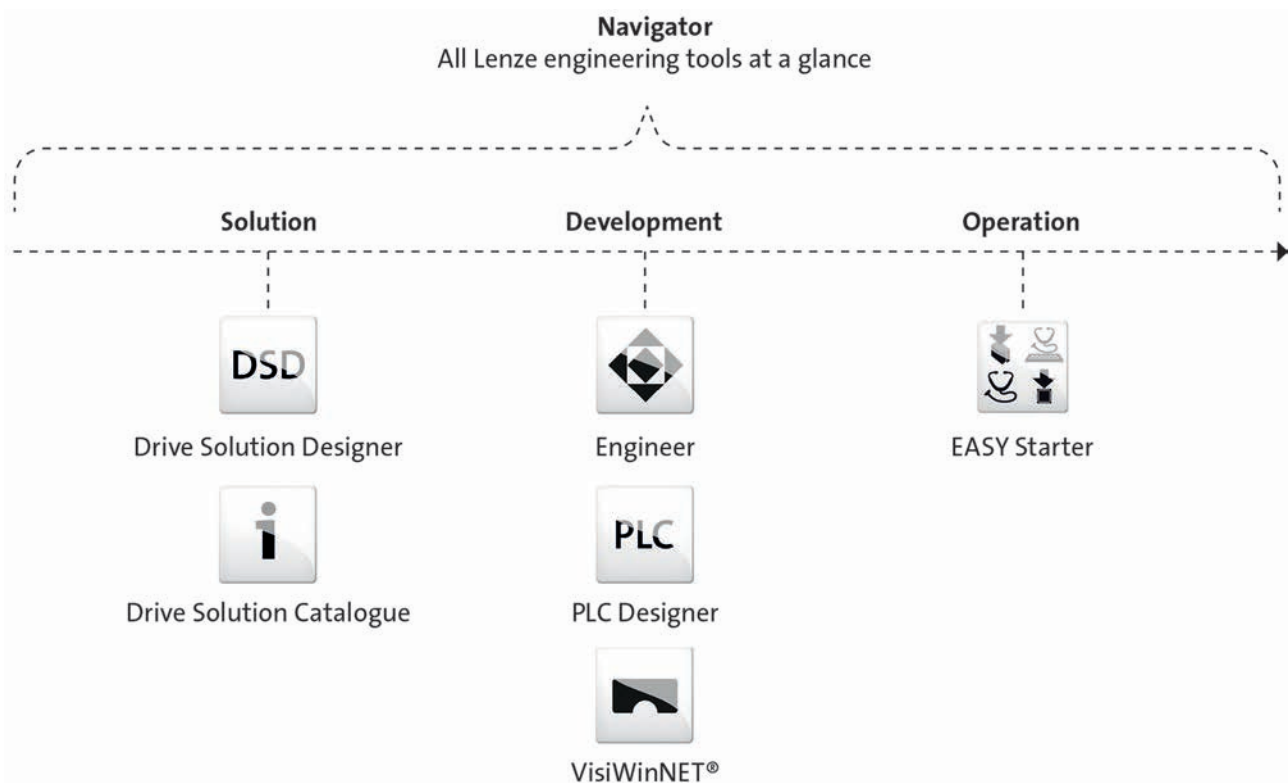

L-force product portfolio

Inverters

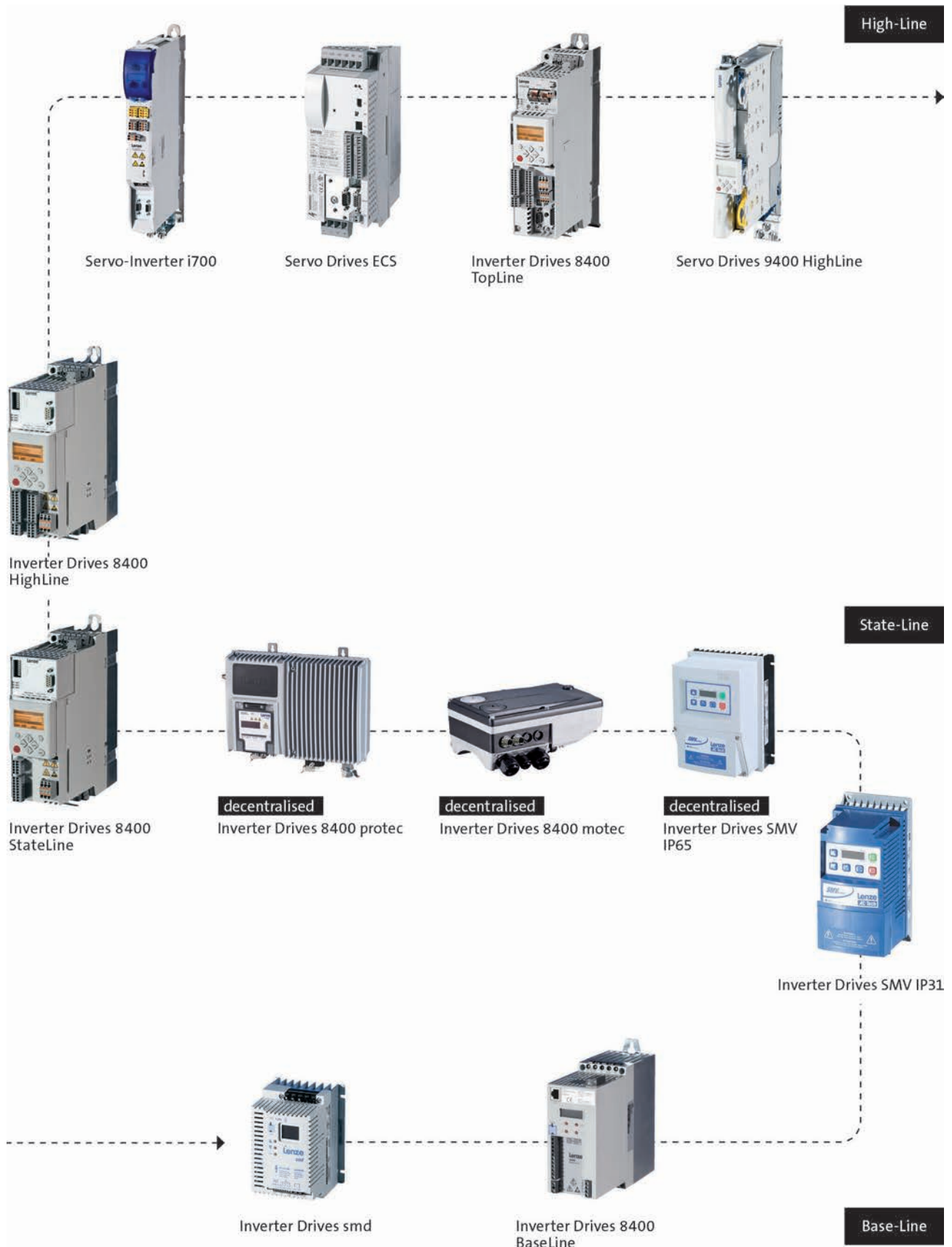

L-force product portfolio

Motors



L-force product portfolio

Gearboxes

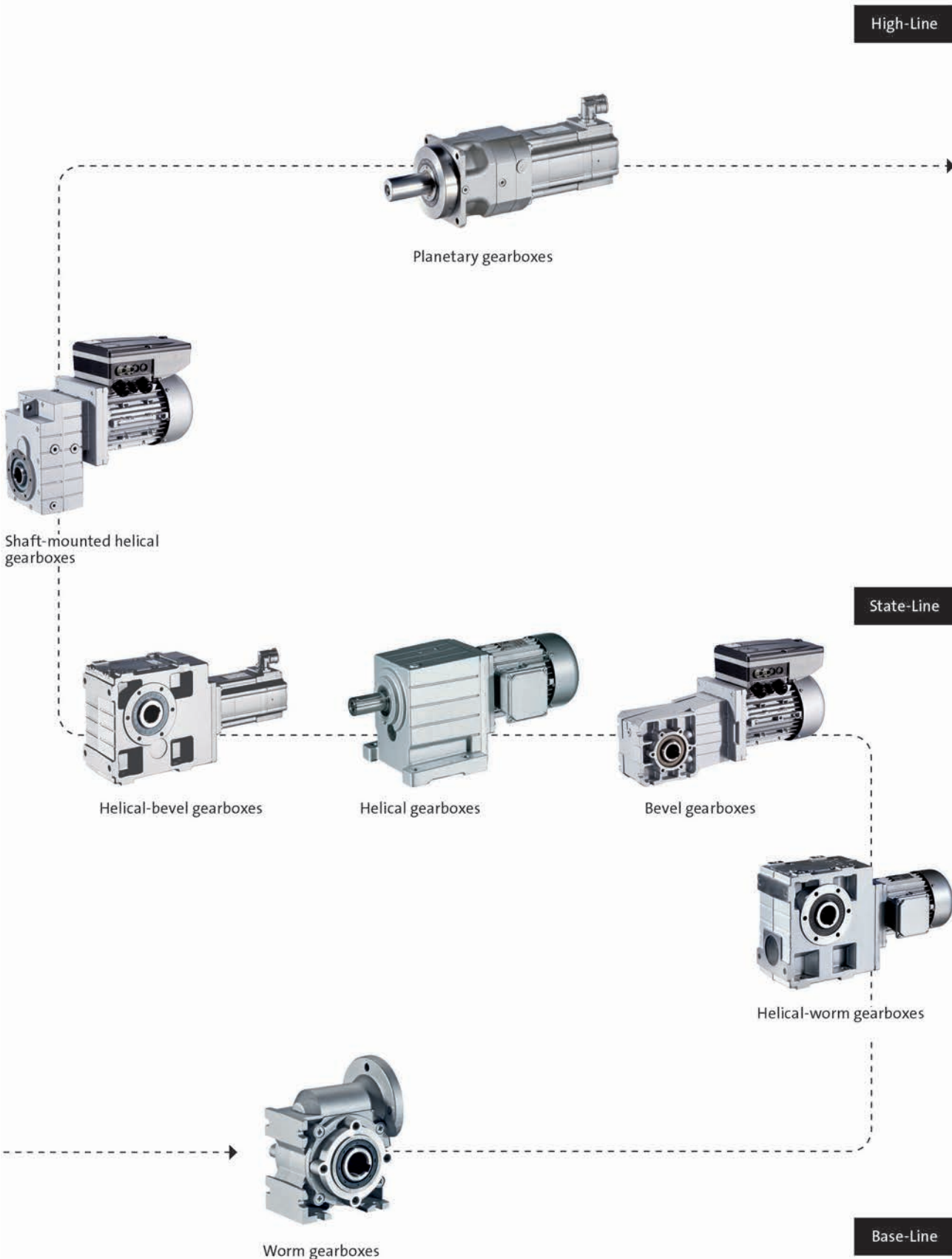

Gearboxes

MPR planetary-geared motors

9 ... 387 Nm (synchronous servo motors)

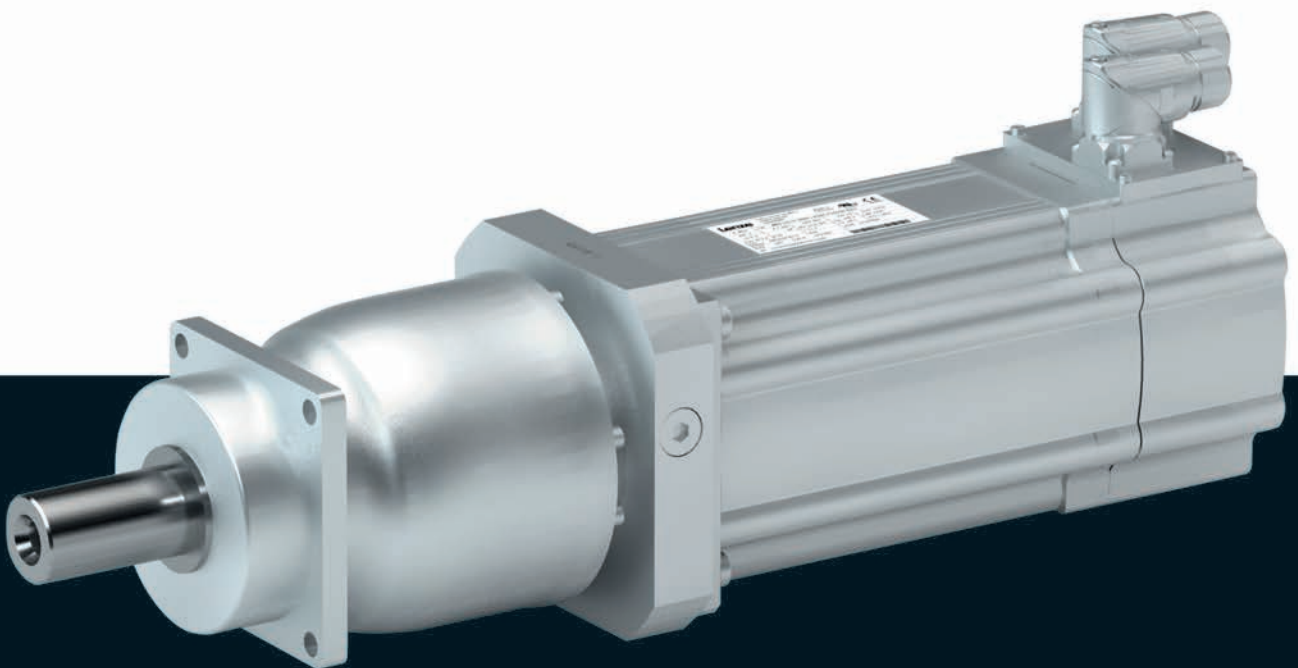

MPR planetary geared motors



Contents

General information	List of abbreviations	6.2.1 - 5
	Product information	6.2.1 - 6
	Equipment	6.2.1 - 7
	The gearbox kit	6.2.1 - 9
	Dimensioning	6.2.1 - 14
Technical data	Selection tables, notes	6.2.1 - 17
	Selection tables	6.2.1 - 18
	Dimensions, notes	6.2.1 - 37
	Dimensions, self-ventilated motors	6.2.1 - 38
	Dimensions, forced ventilated motors	6.2.1 - 53
	Weights, self-ventilated motors	6.2.1 - 61
	Weights, forced ventilated motors	6.2.1 - 61
	Surface and corrosion protection	6.2.1 - 62

MPR planetary geared motors

Contents

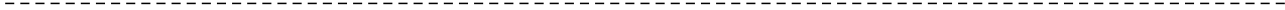

MPR planetary geared motors

General information



List of abbreviations

c		Load capacity
i		Ratio
J	[kgcm ²]	Moment of inertia
m	[kg]	Mass
M ₂	[Nm]	Output torque
M _{2, max}	[Nm]	Max. output torque
n _{2, eto}	[r/min]	Transition speed
n _{2, th}	[r/min]	Thermal limit speed

CCC	China Compulsory Certificate
CE	Communauté Européenne
CSA	Canadian Standards Association
cURus	Combined certification marks of UL for the USA and Canada
DIN	Deutsches Institut für Normung e.V.
EMC	Electromagnetic compatibility
EN	European standard
GOST	Certificate for Russian Federation
IEC	International Electrotechnical Commission
IM	International Mounting Code
IP	International Protection Code
NEMA	National Electrical Manufacturers Association
UL	Underwriters Laboratory Listed Product
UR	Underwriters Laboratory Recognized Product
VDE	Verband deutscher Elektrotechniker (Association of German Electrical Engineers)

MPR planetary geared motors



General information

Product information

The combination of Vogel MPR/MPG planetary gearboxes and Lenze servo motors is the optimum solution for dynamic or highly dynamic applications requiring the highest precision. These solutions cater to the requirements such as those encountered on a daily basis in the printing and packaging industry, as well as in the fields of handling and robot technology, filling and materials handling technology and, in many cases, also general engineering.

The MPR/MPG planetary gearboxes feature a higher-than-average torsional stiffness combined with a backlash down to one angular minute. Their combination with MCS synchronous servo motors and MCA asynchronous servo motors creates flexible and particularly energy-efficient solutions which cover virtually every application.

Version

- Robust planetary gearbox with solid shaft (MPR) or flanged shaft (MPG)
- High precision for the application thanks to low backlash (min. ≤ 1 angular minutes)
- Efficient drive solutions with high efficiency (95 ... 97 %)
- Any mounting position which can be changed subsequently as well
- Enclosure IP65 (dust-tight, protection against water jets under any angle)

The product name

Gearbox type	Product range	Rated torque [Nm]	Product
Planetary gearbox	MPR	29	MPR050
		83	MPR100
		200	MPR200
		390	MPR300

MPR planetary geared motors

General information



Equipment

Overview

The equipment includes all the options available as standard and all the built-on accessories of the product.

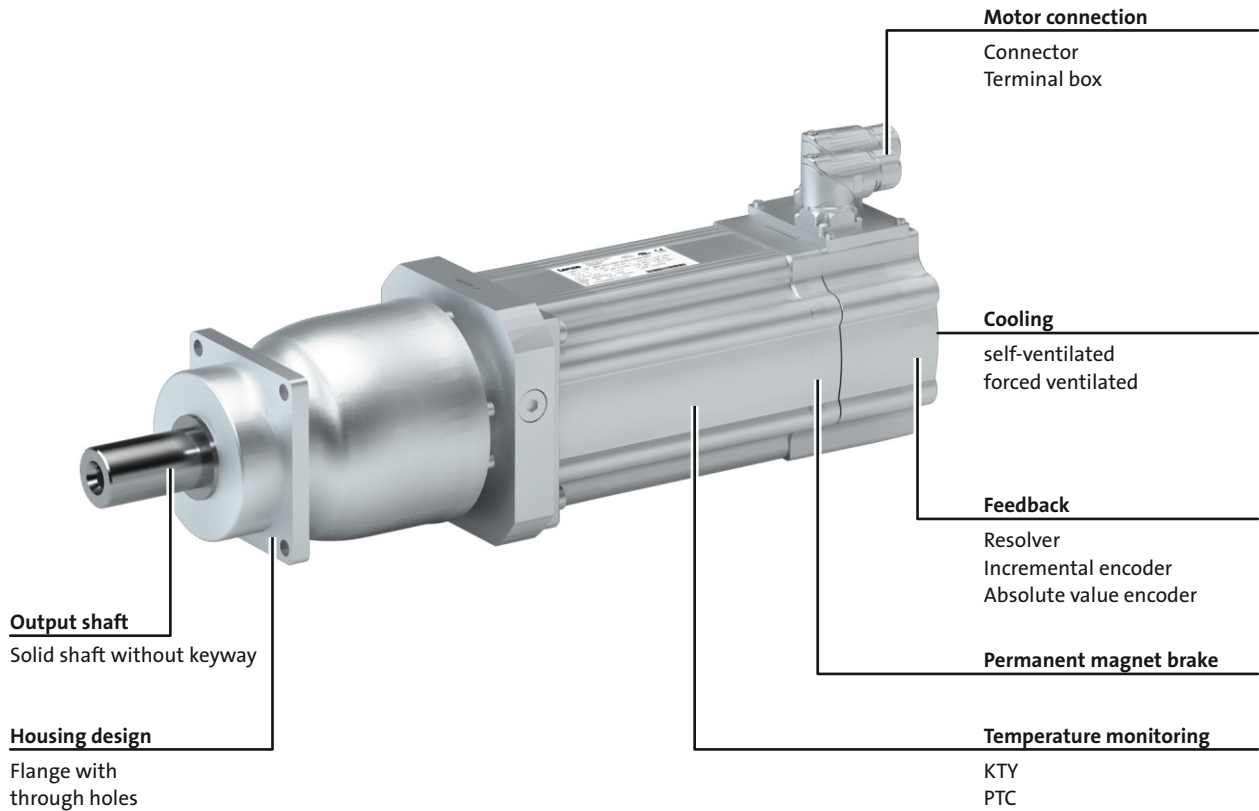

MPR planetary geared motors

General information



MPR planetary geared motors

General information



The gearbox kit

Geared motor

Product	MPR050	MPR100	MPR200	MPR300
Motor type	Synchronous servo motor			
Servo motor				
0.6 - 1.5 Nm	MCS06			
2.3 - 4.5 Nm	MCS09			
5.5 - 17 Nm	MCS12			
9.2 - 42 Nm		MCS14		
27 - 72 Nm			MCS19	
Technical data				
Output torque	See selection table			
Output speed	See selection table			
Ratio	See selection table			
Load capacity	See selection table			
Moment of inertia	See selection table			
Mounting position				
Standard	Any			
Colour				
	primed (RAL 9005M, matt jet black)			
Surface and corrosion protection				
	Without OKS(uncoated) OKS-G (primed)			

MPR planetary geared motors

General information



The gearbox kit

Motor details

Product	MCS				
	06C41	09L41	12H14	14D14	19F12
	06C60	09D41	12L17	14L14	19P12
	06F41	09L51	12D17	14H12	19J12
	06F60	09D60	12L20	14P11	19P14
	06I41	09F38	12H15	14P14	19J14
	06I60	09F60	12D20	14D15	19F14
		09H41	12D35	14H15	19J29
		09H60	12H34	14L15	19P29
			12L39	14H28	19F29
			12D41	14P26	19J30
			12H35	14L30	19F30
			12L41	14D30	19P30
				14H32	
				14P32	
				14D36	
				14L32	
Connection type	Plug connectors		Plug connectors Terminal box		
Permanent magnet holding brake					
Rated torque [Nm]	2.2	8.0	12	22	37
Brake voltage [V]	DC 24				
Feedback	With absolute value encoder With incremental encoder With resolver				
Cooling	Self-ventilated		Self-ventilated Forced-ventilated		
Temperature monitoring	KTY83-110 thermal detector		KTY83-110 thermal detector PTC thermistor		
Approval	cURus GOST_R UkrSepro				
Degree of protection	IP54 IP65				

- Further information and installation feasibilities can be found in the Motors chapter.







MPR planetary geared motors

General information



The gearbox kit

Motor details

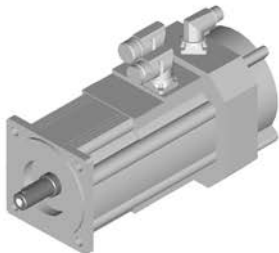
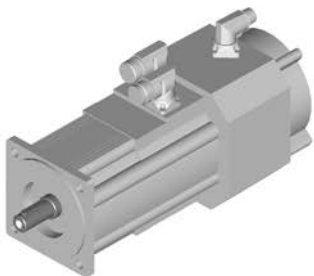
Connection type		
 Plug connectors	 Terminal box	
Cooling: self-ventilated		
 With resolver	 With permanent magnet brake	 With feedback With feedback and permanent magnet brake
Cooling: forced ventilated		
 With resolver	 With permanent magnet brake	 With feedback With feedback and permanent magnet brake

6.2.1

MPR planetary geared motors

General information



The gearbox kit

Gearbox details

Product	MPR050	MPR100	MPR200	MPR300
Driven shaft				
Solid shaft without keyway [mm]	16x28	22x36	32x58	40x82
Design	Standard			
Gasket	NBR			
Bearing	Standard			
Housing				
Housing version	Without foot with centering			
Output flange				
Flange square [mm]	62	76	101	141
Lubricant				
Type	Mobil SHC 629			
Breather element	Without			
Backlash				
Backlash	Standard Reduced			

- Further information and installation feasibilities can be found in the Gearboxes chapter.

MPR planetary geared motors

General information



The gearbox kit

Gearbox details

Solid shaft



With centering

MPR planetary geared motors



General information

Dimensioning

General information about the data provided in this catalogue

The powers, torques and speeds specified in this catalogue are rounded values and are valid under the following conditions:

- Operating time/day = 8 h (100% OT)
- Duty class I for up to 10 switching operations/h
- Mounting positions and designs in this catalogue
- Standard lubricant
- $T_{amb} = 30\text{ °C}$ for gearboxes,
 $T_{amb} = 40\text{ °C}$ for motors (in accordance with EN 60034)
- Site altitude $< = 1000\text{ m amsl}$
- The selection tables provide the permissible mechanical powers and torques. For notes on the thermal power limit, see chapter drive dimensioning.
- The rated power specified for motors and geared motors applies to operating mode S1 (in accordance with EN 60034).

Under different operating conditions, the values obtained may vary from those listed here.

In the case of extreme operating conditions, please consult your Lenze sales office.

MPR planetary geared motors



General information

Dimensioning

Load capacity and application factor

Load capacity c of gearbox

Rated value for the load capacity of Lenze geared motors.

- c is the ratio of the permissible rated torque of the gearbox to the rated torque supplied by the drive component (e.g. the built-in Lenze motor).
- The value of c must always be greater than the value of the application factor k calculated for the application.

Application factor k (according to DIN 3990)

Takes into account the influence of temporally variable loads which are actually present during the anticipated operating time of gearboxes and geared motors.

k is determined by:

- the type of load
- the load intensity
- temporal influences

Duty class	Load type
I	Smooth operation, small or light jolts
II	Uneven operation, average jolts
III	Uneven operation, severe jolts and/or alternating load

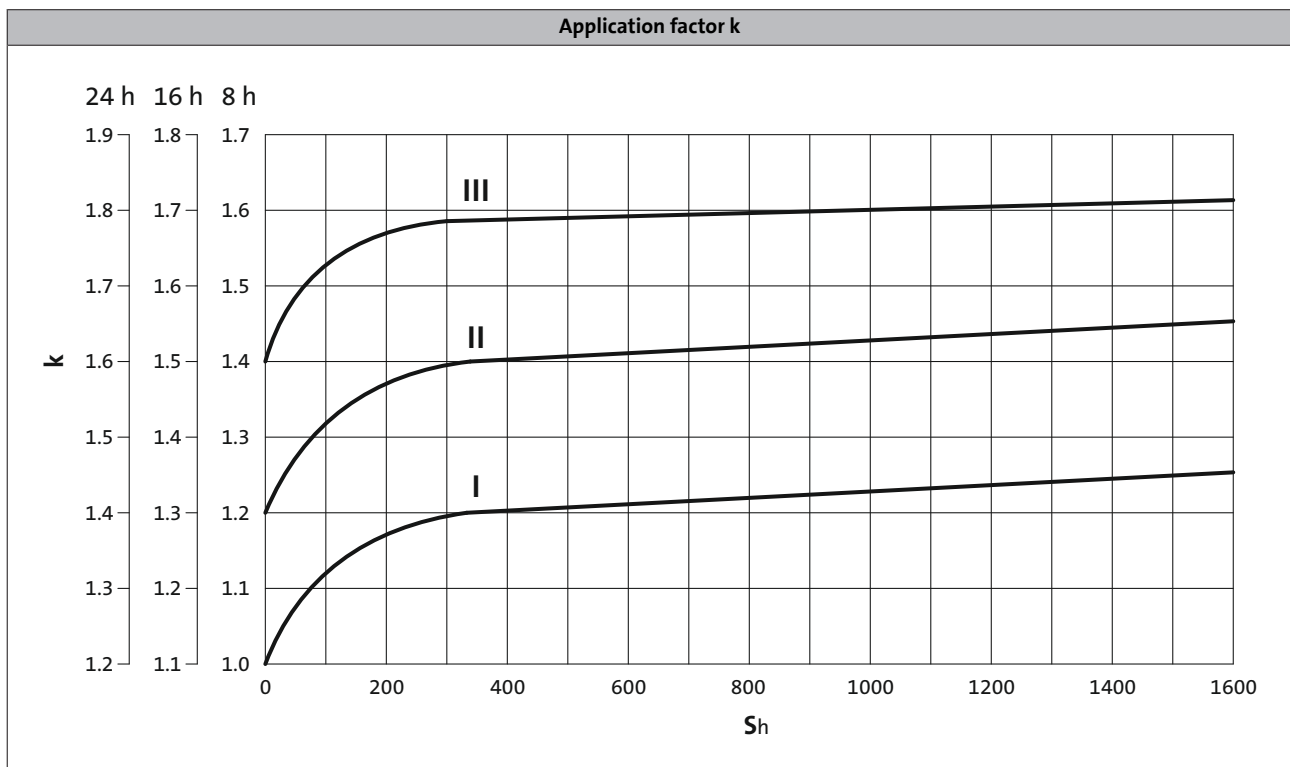

► S_h = switchings/h

MPR planetary geared motors



General information

Dimensioning

Weights

The values given in the tables consider the following gearbox/motor combination:

- Gearbox with solid shaft including lubricant amount
- Motor with feedback

For versions deviating from this, additional weights have to be considered.

The respective values can be found for:

- Geared motors with feedback
 - > Chapter: Geared motors/Technical data
- Motor options: Brake
 - > Chapter: Motors/Accessories

Moments of inertia

The given moments of inertia of the gearbox refer to the drive shaft. The influence of the ratio (i^2) has been considered in the data.

When the total moment of inertia of the geared motor is calculated, the values of the geared motors and the brake have to be added.

The respective values can be found for:

- Geared motors with feedback
 - > Chapter: Geared motors/Technical data/Selection tables
- Motor options: Brake
 - > Chapter: Motors/Accessories

MPR planetary geared motors



Technical data

Selection tables, notes

Notes on the selection tables

The selection tables show the available combinations of gearbox type, number of stages, ratio and motor. They are used only to provide basic orientation.

The following legend indicates the structure of the selection tables.

Number of the gear stage of the gearbox



2-stage gearboxes

Inverter operation						i	Product		Cooling	
M _{2, max} [Nm]	n _{2, th} [r/min]	M ₂ [Nm]	n _{2, eto} [r/min]	c	J [kgcm ²]		MPR	MCS		
20	333	6	333	3.6	0.300	12.000	050	06C60	Selbst	40
20	333	7	333	3.0	0.300	12.000	050	06C41	Selbst	40
20	333	10	333	1.9	0.400	12.000	050	06F60	Selbst	40
20	333	14	333	1.5	0.400	12.000	050	06F41	Selbst	40

For operating mode S1
Torque M₂ and
thermal output speed n_{2, th}

For operating mode S2, S3 und S6
Max. permissible acceleration torque of geared
motor M_{2, max} and
output speed n_{2, eto}

Moment of inertia of
geared motor

Ratio i

Product
Gearbox

Product
Motor

Type of
motor cooling

Page number
for dimensions

Load capacity of the gearbox
c is the ratio between the permissible rated torque of the
gearbox and the rated torque of the three-phase AC
motor (converted to the driven shaft).
c must be always higher than the service factor k
determined for the application k.

$$c = \frac{M_{2, zul}}{M_{1N} \cdot i \cdot \eta_{Getr}} > k$$

MPR planetary geared motors

Technical data



Selection tables

1-stage gearboxes

Inverter operation						i	Product		Cooling	
M _{2, max} [Nm]	n _{2, th} [r/min]	M ₂ [Nm]	n _{2, eto} [r/min]	c	J [kgcm ²]		MPR	MCS		
13	1100	3	1100	5.7	0.600	3.000	050	06F41	natural	38
18	1100	3	1100	5.8	0.600	3.000	050	06I60	natural	38
18	1100	4	1100	4.5	0.600	3.000	050	06I41	natural	38
19	400	5	400	4.0	0.300	10.000	050	06C60	natural	38
19	400	6	400	3.3	0.300	10.000	050	06C41	natural	38
19	400	9	400	2.2	0.400	10.000	050	06F60	natural	38
19	400	12	400	1.6	0.400	10.000	050	06F41	natural	38
19	400	12	400	1.6	0.500	10.000	050	06I60	natural	38
19	400	15	400	1.3	0.500	10.000	050	06I41	natural	38
19	400	17	400	1.1	1.300	10.000	050	09D60	natural	38
20	1100	5	1100	3.9	1.500	3.000	050	09D60	natural	38
20	1100	7	1100	2.9	1.900	3.000	050	09F60	natural	38
20	1100	7	1100	2.9	1.500	3.000	050	09D41	natural	38
20	1100	9	1100	2.3	1.900	3.000	050	09F38	natural	38
20	1100	9	1100	2.3	2.300	3.000	050	09H60	natural	38
20	1100	10	1100	1.9	3.200	3.000	050	09L51	natural	38
20	1100	11	1100	1.8	2.300	3.000	050	09H41	natural	38
20	1100	12	1100	1.6	4.500	3.000	050	12D41	natural	38
20	1100	13	1100	1.5	3.200	3.000	050	09L41	natural	38
20	1100	17	1100	1.1	4.500	3.000	050	12D35	forced	53
20	650	16	650	1.3	4.500	3.000	050	12D20	natural	38
21	660	6	660	5.0	0.400	5.000	050	06F41	natural	38
24	825	6	825	5.0	0.500	4.000	050	06I41	natural	38
29	825	7	825	4.3	1.400	4.000	050	09D60	natural	38
29	825	9	825	3.1	1.800	4.000	050	09F60	natural	38
29	825	9	825	3.2	1.400	4.000	050	09D41	natural	38
29	825	12	825	2.5	1.800	4.000	050	09F38	natural	38
29	825	12	825	2.5	2.200	4.000	050	09H60	natural	38
29	825	14	825	2.1	3.100	4.000	050	09L51	natural	38
29	825	15	825	2.0	2.200	4.000	050	09H41	natural	38
29	825	16	825	1.8	4.400	4.000	050	12D41	natural	38
29	825	17	825	1.7	3.100	4.000	050	09L41	natural	38
29	825	23	825	1.3	4.400	4.000	050	12D35	forced	53
29	660	6	660	5.0	0.500	5.000	050	06I60	natural	38
29	660	7	660	4.0	0.500	5.000	050	06I41	natural	38
29	660	8	660	3.4	1.300	5.000	050	09D60	natural	38
29	660	11	660	2.5	1.300	5.000	050	09D41	natural	38
29	660	12	660	2.5	1.700	5.000	050	09F60	natural	38
29	660	15	660	2.0	1.700	5.000	050	09F38	natural	38
29	660	15	660	2.0	2.100	5.000	050	09H60	natural	38

6.2.1

MPR planetary geared motors

Technical data



Selection tables

1-stage gearboxes

Inverter operation						i	Product		Cooling	
M _{2, max} [Nm]	n _{2, th} [r/min]	M ₂ [Nm]	n _{2, eto} [r/min]	c	J [kgcm ²]		MPR	MCS		
29	660	17	660	1.7	3.000	5.000	050	09L51	natural	38
29	660	18	660	1.6	2.100	5.000	050	09H41	natural	38
29	660	21	660	1.4	4.400	5.000	050	12D41	natural	38
29	660	22	660	1.3	3.000	5.000	050	09L41	natural	38
29	660	29	660	1.0	4.400	5.000	050	12D35	forced	53
29	529	6	529	4.7	0.400	7.000	050	06F60	natural	38
29	529	8	529	3.5	0.400	7.000	050	06F41	natural	38
29	529	8	529	3.6	0.500	7.000	050	06I60	natural	38
29	529	10	529	2.8	0.500	7.000	050	06I41	natural	38
29	529	12	529	2.4	1.300	7.000	050	09D60	natural	38
29	529	16	529	1.8	1.700	7.000	050	09F60	natural	38
29	529	16	529	1.8	1.300	7.000	050	09D41	natural	38
29	529	21	529	1.4	1.700	7.000	050	09F38	natural	38
29	529	21	529	1.4	2.100	7.000	050	09H60	natural	38
29	529	24	529	1.2	3.000	7.000	050	09L51	natural	38
29	529	26	529	1.1	2.100	7.000	050	09H41	natural	38
29	529	29	529	1.0	4.300	7.000	050	12D41	natural	38
29	488	21	488	1.4	4.400	4.000	050	12D20	natural	38
29	413	27	413	1.1	4.400	4.000	050	12D17	forced	53
29	390	26	390	1.1	4.400	5.000	050	12D20	natural	38
52	933	12	933	4.5	5.200	3.000	100	12D41	natural	41
52	933	17	933	3.2	5.200	3.000	100	12D35	forced	54
52	650	16	650	3.6	5.200	3.000	100	12D20	natural	41
52	550	20	550	2.8	5.200	3.000	100	12D17	forced	54
56	933	10	933	5.4	3.900	3.000	100	09L51	natural	41
56	933	11	933	5.1	3.000	3.000	100	09H41	natural	41
56	933	13	933	4.3	3.900	3.000	100	09L41	natural	41
56	933	22	933	2.5	8.500	3.000	100	12H35	natural	41
56	933	22	933	2.6	10.000	3.000	100	14D36	natural	41
56	933	23	933	2.4	8.500	3.000	100	12H30	natural	41
56	933	30	933	1.8	8.500	3.000	100	12H34	forced	54
56	933	31	933	1.8	10.000	3.000	100	14D30	forced	54
56	933	32	933	1.7	12.000	3.000	100	12L41	natural	41
56	933	41	933	1.4	12.000	3.000	100	12L39	forced	54
56	650	40	650	1.4	12.000	3.000	100	12L20	natural	41
56	550	49	550	1.1	12.000	3.000	100	12L17	forced	54
56	500	27	500	2.1	10.000	3.000	100	14D15	natural	41
56	500	30	500	1.9	8.500	3.000	100	12H15	natural	41
56	450	35	450	1.6	8.500	3.000	100	12H14	forced	54
56	450	35	450	1.6	10.000	3.000	100	14D14	forced	54

6.2.1

MPR planetary geared motors

Technical data



Selection tables

1-stage gearboxes

Inverter operation						i	Product		Cooling	
M _{2, max} [Nm]	n _{2, th} [r/min]	M ₂ [Nm]	n _{2, eto} [r/min]	c	J [kgcm ²]		MPR	MCS		
58	310	17	310	3.4	1.600	10.000	100	09D60	natural	41
58	310	23	310	2.5	1.600	10.000	100	09D41	natural	41
58	310	23	310	2.5	2.000	10.000	100	09F60	natural	41
58	310	29	310	2.0	2.400	10.000	100	09H60	natural	41
58	310	30	310	2.0	2.000	10.000	100	09F38	natural	41
58	310	35	310	1.7	3.300	10.000	100	09L51	natural	41
58	310	37	310	1.6	2.400	10.000	100	09H41	natural	41
58	310	41	310	1.4	4.600	10.000	100	12D41	natural	41
58	310	43	310	1.3	3.300	10.000	100	09L41	natural	41
58	310	58	310	1.0	4.600	10.000	100	12D35	forced	54
58	195	52	195	1.1	4.600	10.000	100	12D20	natural	41
65	400	16	400	5.2	1.600	7.000	100	09D41	natural	41
69	700	23	700	3.6	4.900	4.000	100	12D35	forced	54
69	413	27	413	3.1	4.900	4.000	100	12D17	forced	54
70	700	16	700	5.0	4.900	4.000	100	12D41	natural	41
70	488	21	488	4.0	4.900	4.000	100	12D20	natural	41
73	560	15	560	5.6	2.100	5.000	100	09F38	natural	41
78	700	15	700	5.7	2.600	4.000	100	09H41	natural	41
83	700	17	700	4.8	3.500	4.000	100	09L41	natural	41
83	700	29	700	2.8	8.200	4.000	100	12H35	natural	41
83	700	29	700	2.9	9.700	4.000	100	14D36	natural	41
83	700	31	700	2.7	8.200	4.000	100	12H30	natural	41
83	700	41	700	2.0	8.200	4.000	100	12H34	forced	54
83	700	41	700	2.0	9.700	4.000	100	14D30	forced	54
83	700	43	700	1.9	11.000	4.000	100	12L41	natural	41
83	700	54	700	1.5	11.000	4.000	100	12L39	forced	54
83	560	15	560	5.7	2.500	5.000	100	09H60	natural	41
83	560	17	560	4.8	3.400	5.000	100	09L51	natural	41
83	560	18	560	4.5	2.500	5.000	100	09H41	natural	41
83	560	21	560	4.0	4.800	5.000	100	12D41	natural	41
83	560	22	560	3.8	3.400	5.000	100	09L41	natural	41
83	560	29	560	2.9	4.800	5.000	100	12D35	forced	54
83	560	36	560	2.3	9.600	5.000	100	14D36	natural	41
83	560	37	560	2.3	8.100	5.000	100	12H35	natural	41
83	560	39	560	2.1	8.100	5.000	100	12H30	natural	41
83	560	51	560	1.6	8.100	5.000	100	12H34	forced	54
83	560	51	560	1.6	9.600	5.000	100	14D30	forced	54
83	560	54	560	1.5	11.000	5.000	100	12L41	natural	41
83	560	68	560	1.2	11.000	5.000	100	12L39	forced	54
83	488	53	488	1.6	11.000	4.000	100	12L20	natural	41

6.2.1

MPR planetary geared motors

Technical data



Selection tables

1-stage gearboxes

Inverter operation						i	Product		Cooling	
M _{2, max} [Nm]	n _{2, th} [r/min]	M ₂ [Nm]	n _{2, eto} [r/min]	c	J [kgcm ²]		MPR	MCS		
83	413	65	413	1.3	11.000	4.000	100	12L17	forced	54
83	400	16	400	5.1	2.000	7.000	100	09F60	natural	41
83	400	21	400	4.0	2.400	7.000	100	09H60	natural	41
83	400	21	400	4.0	2.000	7.000	100	09F38	natural	41
83	400	24	400	3.4	3.300	7.000	100	09L51	natural	41
83	400	26	400	3.2	2.400	7.000	100	09H41	natural	41
83	400	29	400	2.9	4.700	7.000	100	12D41	natural	41
83	400	30	400	2.7	3.300	7.000	100	09L41	natural	41
83	400	40	400	2.0	4.700	7.000	100	12D35	forced	54
83	400	50	400	1.6	9.500	7.000	100	14D36	natural	41
83	400	52	400	1.6	8.000	7.000	100	12H35	natural	41
83	400	54	400	1.5	8.000	7.000	100	12H30	natural	41
83	400	71	400	1.2	8.000	7.000	100	12H34	forced	54
83	400	71	400	1.2	9.500	7.000	100	14D30	forced	54
83	400	75	400	1.1	11.000	7.000	100	12L41	natural	41
83	390	26	390	3.2	4.800	5.000	100	12D20	natural	41
83	390	67	390	1.3	11.000	5.000	100	12L20	natural	41
83	375	36	375	2.3	9.700	4.000	100	14D15	natural	41
83	375	40	375	2.1	8.200	4.000	100	12H15	natural	41
83	338	47	338	1.8	8.200	4.000	100	12H14	forced	54
83	338	47	338	1.8	9.700	4.000	100	14D14	forced	54
83	330	34	330	2.5	4.800	5.000	100	12D17	forced	54
83	330	81	330	1.0	11.000	5.000	100	12L17	forced	54
83	300	45	300	1.9	9.600	5.000	100	14D15	natural	41
83	300	49	300	1.7	8.100	5.000	100	12H15	natural	41
83	279	37	279	2.3	4.700	7.000	100	12D20	natural	41
83	270	58	270	1.4	8.100	5.000	100	12H14	forced	54
83	270	58	270	1.4	9.600	5.000	100	14D14	forced	54
83	236	47	236	1.8	4.700	7.000	100	12D17	forced	54
83	214	63	214	1.3	9.500	7.000	100	14D15	natural	41
83	214	69	214	1.2	8.000	7.000	100	12H15	natural	41
83	193	82	193	1.0	8.000	7.000	100	12H14	forced	54
83	193	82	193	1.0	9.500	7.000	100	14D14	forced	54
84	833	23	833	5.8	12.000	3.000	200	12H30	natural	45
84	833	30	833	4.4	12.000	3.000	200	12H34	forced	55
84	833	31	833	4.4	13.000	3.000	200	14D30	forced	55
84	500	27	500	5.0	13.000	3.000	200	14D15	natural	45
84	500	30	500	4.5	12.000	3.000	200	12H15	natural	45
84	450	35	450	3.9	12.000	3.000	200	12H14	forced	55
84	450	35	450	3.9	13.000	3.000	200	14D14	forced	55

6.2.1

MPR planetary geared motors

Technical data



Selection tables

1-stage gearboxes

Inverter operation						i	Product		Cooling	
M _{2, max} [Nm]	n _{2, th} [r/min]	M ₂ [Nm]	n _{2, eto} [r/min]	c	J [kgcm ²]		MPR	MCS		
86	330	34	330	5.8	6.800	5.000	200	12D17	forced	55
113	625	41	625	4.9	11.000	4.000	200	12H34	forced	55
113	625	41	625	4.9	12.000	4.000	200	14D30	forced	55
113	375	36	375	5.6	12.000	4.000	200	14D15	natural	45
113	375	40	375	5.1	11.000	4.000	200	12H15	natural	45
113	338	47	338	4.3	11.000	4.000	200	12H14	forced	55
113	338	47	338	4.3	12.000	4.000	200	14D14	forced	55
120	400	40	400	4.7	6.400	7.000	200	12D35	forced	55
120	236	47	236	4.0	6.400	7.000	200	12D17	forced	55
122	279	37	279	5.2	6.400	7.000	200	12D20	natural	45
135	833	32	833	4.2	15.000	3.000	200	12L41	natural	45
135	833	40	833	3.3	19.000	3.000	200	14H32	natural	45
135	833	41	833	3.3	15.000	3.000	200	12L39	forced	55
135	833	50	833	2.7	28.000	3.000	200	14L32	natural	45
135	833	60	833	2.3	19.000	3.000	200	14H28	forced	55
135	833	61	833	2.2	72.000	3.000	200	19F30	natural	45
135	833	61	833	2.2	40.000	3.000	200	14P32	natural	45
135	833	74	833	1.8	28.000	3.000	200	14L30	forced	55
135	833	84	833	1.6	112.000	3.000	200	19J30	natural	45
135	833	95	833	1.4	72.000	3.000	200	19F29	forced	55
135	833	96	833	1.4	40.000	3.000	200	14P26	forced	55
135	650	40	650	3.4	15.000	3.000	200	12L20	natural	45
135	550	49	550	2.8	15.000	3.000	200	12L17	forced	55
135	500	46	500	2.9	19.000	3.000	200	14H15	natural	45
135	500	67	500	2.0	28.000	3.000	200	14L15	natural	45
135	475	78	475	1.7	72.000	3.000	200	19F14	natural	45
135	475	117	475	1.1	112.000	3.000	200	19J14	natural	45
135	450	86	450	1.6	40.000	3.000	200	14P14	natural	45
135	450	89	450	1.5	28.000	3.000	200	14L14	forced	55
135	400	69	400	1.9	19.000	3.000	200	14H12	forced	55
135	400	111	400	1.2	72.000	3.000	200	19F12	forced	55
135	350	122	350	1.1	40.000	3.000	200	14P11	forced	55
135	280	41	280	3.3	6.200	10.000	200	12D41	natural	45
135	280	58	280	2.3	6.200	10.000	200	12D35	forced	55
135	280	72	280	1.9	11.000	10.000	200	14D36	natural	45
135	280	74	280	1.8	9.500	10.000	200	12H35	natural	45
135	280	77	280	1.8	9.500	10.000	200	12H30	natural	45
135	280	102	280	1.3	9.500	10.000	200	12H34	forced	55
135	280	102	280	1.3	11.000	10.000	200	14D30	forced	55
135	280	107	280	1.3	13.000	10.000	200	12L41	natural	45

6.2.1

MPR planetary geared motors

Technical data



Selection tables

1-stage gearboxes

Inverter operation						i	Product		Cooling	
M _{2, max} [Nm]	n _{2, th} [r/min]	M ₂ [Nm]	n _{2, eto} [r/min]	c	J [kgcm ²]		MPR	MCS		
135	280	135	280	1.0	17.000	10.000	200	14H32	natural	45
135	195	52	195	2.6	6.200	10.000	200	12D20	natural	45
135	195	133	195	1.0	13.000	10.000	200	12L20	natural	45
135	165	67	165	2.0	6.200	10.000	200	12D17	forced	55
135	150	90	150	1.5	11.000	10.000	200	14D15	natural	45
135	150	99	150	1.4	9.500	10.000	200	12H15	natural	45
135	135	117	135	1.2	9.500	10.000	200	12H14	forced	55
135	135	117	135	1.2	11.000	10.000	200	14D14	forced	55
141	500	36	500	5.4	11.000	5.000	200	14D36	natural	45
141	500	37	500	5.3	10.000	5.000	200	12H35	natural	45
141	500	39	500	5.0	10.000	5.000	200	12H30	natural	45
141	500	51	500	3.8	10.000	5.000	200	12H34	forced	55
141	500	51	500	3.8	11.000	5.000	200	14D30	forced	55
141	300	45	300	4.4	11.000	5.000	200	14D15	natural	45
141	300	49	300	4.0	10.000	5.000	200	12H15	natural	45
141	270	58	270	3.3	10.000	5.000	200	12H14	forced	55
141	270	58	270	3.3	11.000	5.000	200	14D14	forced	55
159	700	60	700	4.8	28.000	3.000	300	14H28	forced	58
159	400	69	400	4.2	28.000	3.000	300	14H12	forced	58
190	400	50	400	3.8	11.000	7.000	200	14D36	natural	45
190	400	52	400	3.7	9.700	7.000	200	12H35	natural	45
190	400	54	400	3.5	9.700	7.000	200	12H30	natural	45
190	400	71	400	2.7	9.700	7.000	200	12H34	forced	55
190	400	71	400	2.7	11.000	7.000	200	14D30	forced	55
190	400	75	400	2.5	13.000	7.000	200	12L41	natural	45
190	400	94	400	2.0	17.000	7.000	200	14H32	natural	45
190	400	95	400	2.0	13.000	7.000	200	12L39	forced	55
190	400	117	400	1.6	26.000	7.000	200	14L32	natural	45
190	400	143	400	1.3	70.000	7.000	200	19F30	natural	45
190	400	143	400	1.3	38.000	7.000	200	14P32	natural	45
190	400	173	400	1.1	26.000	7.000	200	14L30	forced	55
190	396	140	396	1.4	17.000	7.000	200	14H28	forced	55
190	279	93	279	2.0	13.000	7.000	200	12L20	natural	45
190	236	114	236	1.7	13.000	7.000	200	12L17	forced	55
190	214	63	214	3.0	11.000	7.000	200	14D15	natural	45
190	214	69	214	2.8	9.700	7.000	200	12H15	natural	45
190	214	108	214	1.8	17.000	7.000	200	14H15	natural	45
190	214	156	214	1.2	26.000	7.000	200	14L15	natural	45
190	204	182	204	1.0	70.000	7.000	200	19F14	natural	45
190	193	82	193	2.3	9.700	7.000	200	12H14	forced	55

6.2.1

MPR planetary geared motors



Technical data

Selection tables

1-stage gearboxes

Inverter operation						i	Product		Cooling	
M _{2, max} [Nm]	n _{2, th} [r/min]	M ₂ [Nm]	n _{2, eto} [r/min]	c	J [kgcm ²]		MPR	MCS		
190	193	82	193	2.3	11.000	7.000	200	14D14	forced	55
190	171	162	171	1.2	17.000	7.000	200	14H12	forced	55
195	500	54	500	3.6	13.000	5.000	200	12L41	natural	45
195	500	67	500	2.9	18.000	5.000	200	14H32	natural	45
195	500	68	500	2.9	13.000	5.000	200	12L39	forced	55
195	500	83	500	2.3	27.000	5.000	200	14L32	natural	45
195	500	100	500	1.9	18.000	5.000	200	14H28	forced	55
195	500	102	500	1.9	70.000	5.000	200	19F30	natural	45
195	500	102	500	1.9	38.000	5.000	200	14P32	natural	45
195	500	124	500	1.6	27.000	5.000	200	14L30	forced	55
195	500	140	500	1.4	110.000	5.000	200	19J30	natural	45
195	500	158	500	1.2	70.000	5.000	200	19F29	forced	55
195	500	161	500	1.2	38.000	5.000	200	14P26	forced	55
195	390	67	390	2.9	13.000	5.000	200	12L20	natural	45
195	330	81	330	2.4	13.000	5.000	200	12L17	forced	55
195	300	77	300	2.5	18.000	5.000	200	14H15	natural	45
195	300	111	300	1.8	27.000	5.000	200	14L15	natural	45
195	285	130	285	1.5	70.000	5.000	200	19F14	natural	45
195	270	144	270	1.4	38.000	5.000	200	14P14	natural	45
195	270	148	270	1.3	27.000	5.000	200	14L14	forced	55
195	240	116	240	1.7	18.000	5.000	200	14H12	forced	55
195	240	185	240	1.1	70.000	5.000	200	19F12	forced	55
197	329	71	329	5.3	15.000	7.000	300	14D30	forced	58
197	193	82	193	4.7	15.000	7.000	300	14D14	forced	58
200	625	43	625	4.7	14.000	4.000	200	12L41	natural	45
200	625	54	625	3.7	14.000	4.000	200	12L39	forced	55
200	625	54	625	3.7	18.000	4.000	200	14H32	natural	45
200	625	67	625	3.0	27.000	4.000	200	14L32	natural	45
200	625	80	625	2.5	18.000	4.000	200	14H28	forced	55
200	625	82	625	2.5	71.000	4.000	200	19F30	natural	45
200	625	82	625	2.5	38.000	4.000	200	14P32	natural	45
200	625	99	625	2.0	27.000	4.000	200	14L30	forced	55
200	625	112	625	1.8	111.000	4.000	200	19J30	natural	45
200	625	126	625	1.6	71.000	4.000	200	19F29	forced	55
200	625	128	625	1.6	38.000	4.000	200	14P26	forced	55
200	488	53	488	3.8	14.000	4.000	200	12L20	natural	45
200	413	65	413	3.1	14.000	4.000	200	12L17	forced	55
200	375	62	375	3.2	18.000	4.000	200	14H15	natural	45
200	375	89	375	2.3	27.000	4.000	200	14L15	natural	45
200	356	104	356	1.9	71.000	4.000	200	19F14	natural	45

6.2.1

MPR planetary geared motors



Technical data

Selection tables

1-stage gearboxes

Inverter operation						i	Product		Cooling	
M _{2, max} [Nm]	n _{2, th} [r/min]	M ₂ [Nm]	n _{2, eto} [r/min]	c	J [kgcm ²]		MPR	MCS		
200	356	156	356	1.3	111.000	4.000	200	19J14	natural	45
200	338	115	338	1.7	38.000	4.000	200	14P14	natural	45
200	338	118	338	1.7	27.000	4.000	200	14L14	forced	55
200	300	93	300	2.2	18.000	4.000	200	14H12	forced	55
200	300	148	300	1.4	71.000	4.000	200	19F12	forced	55
200	263	162	263	1.2	38.000	4.000	200	14P11	forced	55
213	525	80	525	4.9	24.000	4.000	300	14H28	forced	58
213	300	93	300	4.2	24.000	4.000	300	14H12	forced	58
224	700	50	700	5.8	37.000	3.000	300	14L32	natural	49
224	700	74	700	3.9	37.000	3.000	300	14L30	forced	58
224	500	67	500	4.3	37.000	3.000	300	14L15	natural	49
224	450	89	450	3.3	37.000	3.000	300	14L14	forced	58
245	260	72	260	3.4	15.000	10.000	300	14D36	natural	49
245	260	102	260	2.4	15.000	10.000	300	14D30	forced	58
245	260	135	260	1.8	21.000	10.000	300	14H32	natural	49
245	260	167	260	1.5	30.000	10.000	300	14L32	natural	49
245	260	200	260	1.2	21.000	10.000	300	14H28	forced	58
245	260	204	260	1.2	41.000	10.000	300	14P32	natural	49
245	260	204	260	1.2	73.000	10.000	300	19F30	natural	49
245	150	90	150	2.7	15.000	10.000	300	14D15	natural	49
245	150	154	150	1.6	21.000	10.000	300	14H15	natural	49
245	150	222	150	1.1	30.000	10.000	300	14L15	natural	49
245	135	117	135	2.1	15.000	10.000	300	14D14	forced	58
245	120	232	120	1.1	21.000	10.000	300	14H12	forced	58
250	700	61	700	4.7	80.000	3.000	300	19F30	natural	49
250	700	95	700	3.1	80.000	3.000	300	19F29	forced	58
250	475	78	475	3.7	80.000	3.000	300	19F14	natural	49
250	400	111	400	2.6	80.000	3.000	300	19F12	forced	58
266	420	100	420	3.9	22.000	5.000	300	14H28	forced	58
266	240	116	240	3.4	22.000	5.000	300	14H12	forced	58
267	420	67	420	5.8	22.000	5.000	300	14H32	natural	49
267	300	77	300	5.0	22.000	5.000	300	14H15	natural	49
290	700	61	700	4.7	48.000	3.000	300	14P32	natural	49
290	700	84	700	3.4	120.000	3.000	300	19J30	natural	49
290	700	93	700	3.1	175.000	3.000	300	19P30	natural	49
290	700	96	700	3.0	48.000	3.000	300	14P26	forced	58
290	700	147	700	2.0	120.000	3.000	300	19J29	forced	58
290	700	154	700	1.9	175.000	3.000	300	19P29	forced	58
290	475	117	475	2.5	120.000	3.000	300	19J14	natural	49
290	450	86	450	3.4	48.000	3.000	300	14P14	natural	49

6.2.1

MPR planetary geared motors



Technical data

Selection tables

1-stage gearboxes

Inverter operation						i	Product		Cooling	
M _{2, max} [Nm]	n _{2, th} [r/min]	M ₂ [Nm]	n _{2, eto} [r/min]	c	J [kgcm ²]		MPR	MCS		
290	450	148	450	2.0	175.000	3.000	300	19P14	natural	49
290	400	183	400	1.6	120.000	3.000	300	19J12	forced	58
290	400	208	400	1.4	175.000	3.000	300	19P12	forced	58
290	350	122	350	2.4	48.000	3.000	300	14P11	forced	58
299	525	67	525	5.8	33.000	4.000	300	14L32	natural	49
299	525	99	525	4.0	33.000	4.000	300	14L30	forced	58
299	375	89	375	4.4	33.000	4.000	300	14L15	natural	49
299	338	118	338	3.3	33.000	4.000	300	14L14	forced	58
334	525	82	525	4.8	76.000	4.000	300	19F30	natural	49
334	525	126	525	3.1	76.000	4.000	300	19F29	forced	58
334	356	104	356	3.8	76.000	4.000	300	19F14	natural	49
334	300	148	300	2.6	76.000	4.000	300	19F12	forced	58
372	329	140	329	2.7	21.000	7.000	300	14H28	forced	58
372	171	162	171	2.3	21.000	7.000	300	14H12	forced	58
373	420	83	420	4.7	32.000	5.000	300	14L32	natural	49
373	329	94	329	4.0	21.000	7.000	300	14H32	natural	49
373	300	111	300	3.5	32.000	5.000	300	14L15	natural	49
373	214	108	214	3.5	21.000	7.000	300	14H15	natural	49
374	420	124	420	3.2	32.000	5.000	300	14L30	forced	58
374	270	148	270	2.6	32.000	5.000	300	14L14	forced	58
380	329	117	329	3.3	31.000	7.000	300	14L32	natural	49
380	329	143	329	2.7	42.000	7.000	300	14P32	natural	49
380	329	143	329	2.7	74.000	7.000	300	19F30	natural	49
380	329	173	329	2.2	31.000	7.000	300	14L30	forced	58
380	329	197	329	1.9	114.000	7.000	300	19J30	natural	49
380	329	216	329	1.8	169.000	7.000	300	19P30	natural	49
380	329	221	329	1.7	74.000	7.000	300	19F29	forced	58
380	329	225	329	1.7	42.000	7.000	300	14P26	forced	58
380	329	344	329	1.1	114.000	7.000	300	19J29	forced	58
380	329	359	329	1.1	169.000	7.000	300	19P29	forced	58
380	214	156	214	2.4	31.000	7.000	300	14L15	natural	49
380	204	182	204	2.1	74.000	7.000	300	19F14	natural	49
380	204	273	204	1.4	114.000	7.000	300	19J14	natural	49
380	193	202	193	1.9	42.000	7.000	300	14P14	natural	49
380	193	207	193	1.8	31.000	7.000	300	14L14	forced	58
380	193	346	193	1.1	169.000	7.000	300	19P14	natural	49
380	171	259	171	1.5	74.000	7.000	300	19F12	forced	58
380	150	284	150	1.3	42.000	7.000	300	14P11	forced	58
390	525	82	525	4.8	44.000	4.000	300	14P32	natural	49
390	525	112	525	3.5	116.000	4.000	300	19J30	natural	49

6.2.1

MPR planetary geared motors

Technical data



Selection tables

1-stage gearboxes

Inverter operation						i	Product		Cooling	
M _{2, max} [Nm]	n _{2, th} [r/min]	M ₂ [Nm]	n _{2, eto} [r/min]	c	J [kgcm ²]		MPR	MCS		
390	525	124	525	3.2	171.000	4.000	300	19P30	natural	49
390	525	128	525	3.0	44.000	4.000	300	14P26	forced	58
390	525	196	525	2.0	116.000	4.000	300	19J29	forced	58
390	525	205	525	1.9	171.000	4.000	300	19P29	forced	58
390	420	102	420	3.8	43.000	5.000	300	14P32	natural	49
390	420	102	420	3.8	75.000	5.000	300	19F30	natural	49
390	420	140	420	2.8	115.000	5.000	300	19J30	natural	49
390	420	154	420	2.5	170.000	5.000	300	19P30	natural	49
390	420	158	420	2.5	75.000	5.000	300	19F29	forced	58
390	420	161	420	2.4	43.000	5.000	300	14P26	forced	58
390	420	245	420	1.6	115.000	5.000	300	19J29	forced	58
390	420	257	420	1.5	170.000	5.000	300	19P29	forced	58
390	356	156	356	2.5	116.000	4.000	300	19J14	natural	49
390	338	115	338	3.4	44.000	4.000	300	14P14	natural	49
390	338	198	338	2.0	171.000	4.000	300	19P14	natural	49
390	300	244	300	1.6	116.000	4.000	300	19J12	forced	58
390	300	278	300	1.4	171.000	4.000	300	19P12	forced	58
390	285	130	285	3.0	75.000	5.000	300	19F14	natural	49
390	285	195	285	2.0	115.000	5.000	300	19J14	natural	49
390	270	144	270	2.7	43.000	5.000	300	14P14	natural	49
390	270	247	270	1.6	170.000	5.000	300	19P14	natural	49
390	263	162	263	2.4	44.000	4.000	300	14P11	forced	58
390	240	185	240	2.1	75.000	5.000	300	19F12	forced	58
390	240	305	240	1.3	115.000	5.000	300	19J12	forced	58
390	240	347	240	1.1	170.000	5.000	300	19P12	forced	58
390	210	203	210	1.9	43.000	5.000	300	14P11	forced	58

6.2.1

MPR planetary geared motors

Technical data



Selection tables

2-stage gearboxes

Inverter operation						i	Product		Cooling	
M _{2, max} [Nm]	n _{2, th} [r/min]	M ₂ [Nm]	n _{2, eto} [r/min]	c	J [kgcm ²]		MPR	MCS		
20	333	6	333	3.6	0.300	12.000	050	06C60	natural	40
20	333	7	333	3.0	0.300	12.000	050	06C41	natural	40
20	333	10	333	1.9	0.400	12.000	050	06F60	natural	40
20	333	14	333	1.5	0.400	12.000	050	06F41	natural	40
20	333	14	333	1.5	0.500	12.000	050	06I60	natural	40
20	333	17	333	1.2	0.500	12.000	050	06I41	natural	40
20	333	20	333	1.0	1.400	12.000	050	09D60	natural	40
29	275	7	275	3.9	0.300	16.000	050	06C60	natural	40
29	275	14	275	2.1	0.400	16.000	050	06F60	natural	40
29	275	18	275	1.6	0.500	16.000	050	06I60	natural	40
29	275	27	275	1.1	1.300	16.000	050	09D60	natural	40
29	253	9	253	3.2	0.300	16.000	050	06C41	natural	40
29	253	18	253	1.6	0.400	16.000	050	06F41	natural	40
29	253	23	253	1.3	0.500	16.000	050	06I41	natural	40
29	220	9	220	3.1	0.300	20.000	050	06C60	natural	40
29	220	17	220	1.7	0.400	20.000	050	06F60	natural	40
29	220	23	220	1.3	0.500	20.000	050	06I60	natural	40
29	203	11	203	2.6	0.300	20.000	050	06C41	natural	40
29	203	23	203	1.3	0.400	20.000	050	06F41	natural	40
29	203	29	203	1.0	0.500	20.000	050	06I41	natural	40
29	176	12	176	2.5	0.300	25.000	050	06C60	natural	40
29	176	22	176	1.4	0.400	25.000	050	06F60	natural	40
29	176	28	176	1.0	0.500	25.000	050	06I60	natural	40
29	162	14	162	2.1	0.300	25.000	050	06C41	natural	40
29	162	29	162	1.0	0.400	25.000	050	06F41	natural	40
29	157	13	157	2.2	0.300	28.000	050	06C60	natural	40
29	157	24	157	1.2	0.400	28.000	050	06F60	natural	40
29	145	16	145	1.9	0.300	28.000	050	06C41	natural	40
29	126	16	126	1.8	0.300	35.000	050	06C60	natural	40
29	116	20	116	1.5	0.300	35.000	050	06C41	natural	40
29	110	19	110	1.6	0.300	40.000	050	06C60	natural	40
29	101	22	101	1.3	0.300	40.000	050	06C41	natural	40
29	96	23	96	1.2	0.300	50.000	050	06C60	natural	40
29	81	28	81	1.0	0.300	50.000	050	06C41	natural	40
50	258	10	258	5.4	0.500	12.000	100	06F60	natural	43
50	258	14	258	4.1	0.500	12.000	100	06F41	natural	43
56	258	14	258	4.1	0.600	12.000	100	06I60	natural	43
56	258	17	258	3.3	0.600	12.000	100	06I41	natural	43
56	258	20	258	2.8	1.400	12.000	100	09D60	natural	43
56	258	27	258	2.1	1.800	12.000	100	09F60	natural	43

6.2.1

MPR planetary geared motors



Technical data

Selection tables

2-stage gearboxes

Inverter operation						i	Product		Cooling	
M _{2, max} [Nm]	n _{2, th} [r/min]	M ₂ [Nm]	n _{2, eto} [r/min]	c	J [kgcm ²]		MPR	MCS		
56	258	27	258	2.1	1.400	12.000	100	09D41	natural	43
56	258	34	258	1.6	2.200	12.000	100	09H60	natural	43
56	258	35	258	1.6	1.800	12.000	100	09F38	natural	43
56	258	41	258	1.4	3.100	12.000	100	09L51	natural	43
56	258	43	258	1.3	2.200	12.000	100	09H41	natural	43
56	258	51	258	1.1	3.100	12.000	100	09L41	natural	43
57	140	14	140	5.9	0.300	25.000	100	06C41	natural	43
58	45	47	45	1.2	0.300	100.000	100	06C60	natural	43
58	41	56	41	1.0	0.300	100.000	100	06C41	natural	43
64	125	16	125	5.3	0.300	28.000	100	06C41	natural	43
67	219	18	219	4.5	0.500	16.000	100	06F41	natural	43
76	88	19	88	4.0	0.300	40.000	100	06C60	natural	43
76	88	22	88	3.4	0.300	40.000	100	06C41	natural	43
76	88	34	88	2.2	0.400	40.000	100	06F60	natural	43
76	88	45	88	1.7	0.500	40.000	100	06I60	natural	43
76	88	46	88	1.7	0.400	40.000	100	06F41	natural	43
76	88	57	88	1.3	0.500	40.000	100	06I41	natural	43
76	88	67	88	1.1	1.300	40.000	100	09D60	natural	43
80	100	16	100	5.1	0.300	35.000	100	06C60	natural	43
80	100	20	100	4.2	0.300	35.000	100	06C41	natural	43
83	219	18	219	4.6	0.500	16.000	100	06I60	natural	43
83	219	23	219	3.6	0.500	16.000	100	06I41	natural	43
83	219	27	219	3.1	1.400	16.000	100	09D60	natural	43
83	219	36	219	2.3	1.800	16.000	100	09F60	natural	43
83	219	36	219	2.3	1.400	16.000	100	09D41	natural	43
83	219	46	219	1.8	1.800	16.000	100	09F38	natural	43
83	219	46	219	1.8	2.200	16.000	100	09H60	natural	43
83	219	54	219	1.5	3.100	16.000	100	09L51	natural	43
83	219	57	219	1.4	2.200	16.000	100	09H41	natural	43
83	219	68	219	1.2	3.100	16.000	100	09L41	natural	43
83	175	17	175	4.8	0.400	20.000	100	06F60	natural	43
83	175	23	175	3.7	0.500	20.000	100	06I60	natural	43
83	175	23	175	3.6	0.400	20.000	100	06F41	natural	43
83	175	29	175	2.9	0.500	20.000	100	06I41	natural	43
83	175	33	175	2.5	1.300	20.000	100	09D60	natural	43
83	175	45	175	1.8	1.700	20.000	100	09F60	natural	43
83	175	45	175	1.9	1.300	20.000	100	09D41	natural	43
83	175	57	175	1.4	2.100	20.000	100	09H60	natural	43
83	175	58	175	1.4	1.700	20.000	100	09F38	natural	43
83	175	68	175	1.2	3.000	20.000	100	09L51	natural	43

6.2.1

MPR planetary geared motors

Technical data



Selection tables

2-stage gearboxes

Inverter operation						i	Product		Cooling	
M _{2, max} [Nm]	n _{2, th} [r/min]	M ₂ [Nm]	n _{2, eto} [r/min]	c	J [kgcm ²]		MPR	MCS		
83	175	72	175	1.2	2.100	20.000	100	09H41	natural	43
83	140	22	140	3.9	0.400	25.000	100	06F60	natural	43
83	140	28	140	2.9	0.500	25.000	100	06I60	natural	43
83	140	29	140	2.9	0.400	25.000	100	06F41	natural	43
83	140	36	140	2.3	0.500	25.000	100	06I41	natural	43
83	140	42	140	2.0	1.300	25.000	100	09D60	natural	43
83	140	56	140	1.5	1.300	25.000	100	09D41	natural	43
83	140	57	140	1.5	1.700	25.000	100	09F60	natural	43
83	140	72	140	1.2	2.100	25.000	100	09H60	natural	43
83	140	73	140	1.1	1.700	25.000	100	09F38	natural	43
83	125	24	125	3.4	0.400	28.000	100	06F60	natural	43
83	125	32	125	2.6	0.500	28.000	100	06I60	natural	43
83	125	32	125	2.6	0.400	28.000	100	06F41	natural	43
83	125	40	125	2.1	0.500	28.000	100	06I41	natural	43
83	125	47	125	1.8	1.300	28.000	100	09D60	natural	43
83	125	63	125	1.3	1.300	28.000	100	09D41	natural	43
83	125	64	125	1.3	1.700	28.000	100	09F60	natural	43
83	125	80	125	1.0	2.100	28.000	100	09H60	natural	43
83	125	81	125	1.0	1.700	28.000	100	09F38	natural	43
83	100	30	100	2.8	0.400	35.000	100	06F60	natural	43
83	100	40	100	2.1	0.500	35.000	100	06I60	natural	43
83	100	40	100	2.1	0.400	35.000	100	06F41	natural	43
83	100	50	100	1.6	0.500	35.000	100	06I41	natural	43
83	100	58	100	1.4	1.300	35.000	100	09D60	natural	43
83	100	78	100	1.1	1.300	35.000	100	09D41	natural	43
83	100	79	100	1.1	1.700	35.000	100	09F60	natural	43
83	76	23	76	3.5	0.300	50.000	100	06C60	natural	43
83	76	28	76	3.0	0.300	50.000	100	06C41	natural	43
83	76	43	76	1.9	0.400	50.000	100	06F60	natural	43
83	76	57	76	1.5	0.500	50.000	100	06I60	natural	43
83	76	57	76	1.4	0.400	50.000	100	06F41	natural	43
83	76	72	76	1.2	0.500	50.000	100	06I41	natural	43
83	64	33	64	2.5	0.300	70.000	100	06C60	natural	43
83	64	60	64	1.4	0.400	70.000	100	06F60	natural	43
83	64	79	64	1.1	0.500	70.000	100	06I60	natural	43
83	58	39	58	2.1	0.300	70.000	100	06C41	natural	43
83	58	80	58	1.0	0.400	70.000	100	06F41	natural	43
108	233	27	233	5.0	1.900	12.000	200	09D41	natural	47
135	233	27	233	5.0	2.300	12.000	200	09F60	natural	47
135	233	34	233	3.9	2.700	12.000	200	09H60	natural	47

6.2.1

MPR planetary geared motors



Technical data

Selection tables

2-stage gearboxes

Inverter operation						i	Product		Cooling	
M _{2, max} [Nm]	n _{2, th} [r/min]	M ₂ [Nm]	n _{2, eto} [r/min]	c	J [kgcm ²]		MPR	MCS		
135	233	35	233	3.9	2.300	12.000	200	09F38	natural	47
135	233	41	233	3.3	3.600	12.000	200	09L51	natural	47
135	233	43	233	3.1	2.700	12.000	200	09H41	natural	47
135	233	48	233	2.8	5.000	12.000	200	12D41	natural	47
135	233	51	233	2.6	3.600	12.000	200	09L41	natural	47
135	233	68	233	2.0	5.000	12.000	200	12D35	forced	57
135	233	86	233	1.6	8.300	12.000	200	12H35	natural	47
135	233	91	233	1.5	8.300	12.000	200	12H30	natural	47
135	233	119	233	1.1	8.300	12.000	200	12H34	forced	57
135	233	126	233	1.1	12.000	12.000	200	12L41	natural	47
135	163	61	163	2.2	5.000	12.000	200	12D20	natural	47
135	138	79	138	1.7	5.000	12.000	200	12D17	forced	57
135	125	116	125	1.2	8.300	12.000	200	12H15	natural	47
144	194	36	194	5.6	1.900	16.000	200	09D41	natural	47
181	155	33	155	5.9	1.700	20.000	200	09D60	natural	47
181	155	45	155	4.3	1.700	20.000	200	09D41	natural	47
190	60	116	60	1.6	1.600	70.000	200	09D60	natural	47
190	60	159	60	1.2	2.000	70.000	200	09F60	natural	47
190	58	157	58	1.2	1.600	70.000	200	09D41	natural	47
195	155	45	155	4.3	2.100	20.000	200	09F60	natural	47
195	155	57	155	3.4	2.500	20.000	200	09H60	natural	47
195	155	58	155	3.4	2.100	20.000	200	09F38	natural	47
195	155	68	155	2.9	3.400	20.000	200	09L51	natural	47
195	155	72	155	2.7	2.500	20.000	200	09H41	natural	47
195	155	81	155	2.4	4.800	20.000	200	12D41	natural	47
195	155	85	155	2.3	3.400	20.000	200	09L41	natural	47
195	155	113	155	1.7	4.800	20.000	200	12D35	forced	57
195	155	144	155	1.4	8.100	20.000	200	12H35	natural	47
195	150	151	150	1.3	8.100	20.000	200	12H30	natural	47
195	124	42	124	4.7	1.700	25.000	200	09D60	natural	47
195	124	56	124	3.5	1.700	25.000	200	09D41	natural	47
195	124	57	124	3.4	2.100	25.000	200	09F60	natural	47
195	124	72	124	2.7	2.500	25.000	200	09H60	natural	47
195	124	73	124	2.7	2.100	25.000	200	09F38	natural	47
195	124	84	124	2.3	3.400	25.000	200	09L51	natural	47
195	124	90	124	2.2	2.500	25.000	200	09H41	natural	47
195	124	101	124	1.9	4.700	25.000	200	12D41	natural	47
195	124	106	124	1.8	3.400	25.000	200	09L41	natural	47
195	124	142	124	1.4	4.700	25.000	200	12D35	forced	57
195	124	180	124	1.1	8.000	25.000	200	12H35	natural	47

6.2.1

MPR planetary geared motors



Technical data

Selection tables

2-stage gearboxes

Inverter operation						i	Product		Cooling	
M _{2, max} [Nm]	n _{2, th} [r/min]	M ₂ [Nm]	n _{2, eto} [r/min]	c	J [kgcm ²]		MPR	MCS		
195	120	189	120	1.0	8.000	25.000	200	12H30	natural	47
195	98	102	98	1.9	4.800	20.000	200	12D20	natural	47
195	89	58	89	3.4	1.600	35.000	200	09D60	natural	47
195	89	78	89	2.5	1.600	35.000	200	09D41	natural	47
195	89	79	89	2.5	2.000	35.000	200	09F60	natural	47
195	89	101	89	1.9	2.400	35.000	200	09H60	natural	47
195	89	102	89	1.9	2.000	35.000	200	09F38	natural	47
195	89	118	89	1.6	3.300	35.000	200	09L51	natural	47
195	89	125	89	1.6	2.400	35.000	200	09H41	natural	47
195	89	141	89	1.4	4.700	35.000	200	12D41	natural	47
195	89	149	89	1.3	3.300	35.000	200	09L41	natural	47
195	83	132	83	1.5	4.800	20.000	200	12D17	forced	57
195	78	128	78	1.5	4.700	25.000	200	12D20	natural	47
195	75	194	75	1.0	8.100	20.000	200	12H15	natural	47
195	70	83	70	2.3	1.600	50.000	200	09D60	natural	47
195	70	112	70	1.7	1.600	50.000	200	09D41	natural	47
195	70	113	70	1.7	2.000	50.000	200	09F60	natural	47
195	70	144	70	1.4	2.400	50.000	200	09H60	natural	47
195	70	145	70	1.3	2.000	50.000	200	09F38	natural	47
195	70	169	70	1.1	3.300	50.000	200	09L51	natural	47
195	70	179	70	1.1	2.400	50.000	200	09H41	natural	47
195	66	165	66	1.2	4.700	25.000	200	12D17	forced	57
195	56	179	56	1.1	4.700	35.000	200	12D20	natural	47
200	194	36	194	5.5	2.300	16.000	200	09F60	natural	47
200	194	46	194	4.3	2.300	16.000	200	09F38	natural	47
200	194	46	194	4.3	2.700	16.000	200	09H60	natural	47
200	194	54	194	3.7	3.600	16.000	200	09L51	natural	47
200	194	57	194	3.5	2.700	16.000	200	09H41	natural	47
200	194	65	194	3.1	4.900	16.000	200	12D41	natural	47
200	194	68	194	2.9	3.600	16.000	200	09L41	natural	47
200	194	91	194	2.2	4.900	16.000	200	12D35	forced	57
200	194	115	194	1.7	8.200	16.000	200	12H35	natural	47
200	194	159	194	1.3	8.200	16.000	200	12H34	forced	57
200	194	168	194	1.2	12.000	16.000	200	12L41	natural	47
200	188	121	188	1.6	8.200	16.000	200	12H30	natural	47
200	122	82	122	2.4	4.900	16.000	200	12D20	natural	47
200	111	47	111	4.3	1.600	28.000	200	09D60	natural	47
200	111	63	111	3.2	1.600	28.000	200	09D41	natural	47
200	111	64	111	3.1	2.000	28.000	200	09F60	natural	47
200	111	80	111	2.5	2.400	28.000	200	09H60	natural	47

6.2.1

MPR planetary geared motors



Technical data

Selection tables

2-stage gearboxes

Inverter operation						i	Product		Cooling	
M _{2, max} [Nm]	n _{2, th} [r/min]	M ₂ [Nm]	n _{2, eto} [r/min]	c	J [kgcm ²]		MPR	MCS		
200	111	81	111	2.5	2.000	28.000	200	09F38	natural	47
200	111	95	111	2.1	3.300	28.000	200	09L51	natural	47
200	111	100	111	2.0	2.400	28.000	200	09H41	natural	47
200	111	113	111	1.8	4.700	28.000	200	12D41	natural	47
200	111	119	111	1.7	3.300	28.000	200	09L41	natural	47
200	111	159	111	1.3	4.700	28.000	200	12D35	forced	57
200	103	106	103	1.9	4.900	16.000	200	12D17	forced	57
200	94	155	94	1.3	8.200	16.000	200	12H15	natural	47
200	84	183	84	1.1	8.200	16.000	200	12H14	forced	57
200	78	67	78	3.0	1.600	40.000	200	09D60	natural	47
200	78	90	78	2.2	1.600	40.000	200	09D41	natural	47
200	78	91	78	2.2	2.000	40.000	200	09F60	natural	47
200	78	115	78	1.7	2.400	40.000	200	09H60	natural	47
200	78	116	78	1.7	2.000	40.000	200	09F38	natural	47
200	78	135	78	1.5	3.300	40.000	200	09L51	natural	47
200	78	143	78	1.4	2.400	40.000	200	09H41	natural	47
200	78	161	78	1.2	4.600	40.000	200	12D41	natural	47
200	78	170	78	1.2	3.300	40.000	200	09L41	natural	47
200	70	143	70	1.4	4.700	28.000	200	12D20	natural	47
200	59	185	59	1.1	4.700	28.000	200	12D17	forced	57
202	217	68	217	4.3	6.700	12.000	300	12D35	forced	60
202	138	79	138	3.7	6.700	12.000	300	12D17	forced	60
205	217	48	217	6.0	6.700	12.000	300	12D41	natural	51
205	163	61	163	4.7	6.700	12.000	300	12D20	natural	51
269	181	91	181	4.3	6.500	16.000	300	12D35	forced	60
269	103	106	103	3.7	6.500	16.000	300	12D17	forced	60
274	122	82	122	4.8	6.500	16.000	300	12D20	natural	51
290	217	85	217	3.4	11.000	12.000	300	14D36	natural	51
290	217	86	217	3.4	10.000	12.000	300	12H35	natural	51
290	217	91	217	3.2	10.000	12.000	300	12H30	natural	51
290	217	119	217	2.4	10.000	12.000	300	12H34	forced	60
290	217	120	217	2.4	11.000	12.000	300	14D30	forced	60
290	217	126	217	2.3	13.000	12.000	300	12L41	natural	51
290	217	159	217	1.8	13.000	12.000	300	12L39	forced	60
290	217	159	217	1.8	17.000	12.000	300	14H32	natural	51
290	217	196	217	1.5	27.000	12.000	300	14L32	natural	51
290	217	235	217	1.2	17.000	12.000	300	14H28	forced	60
290	217	239	217	1.2	70.000	12.000	300	19F30	natural	51
290	217	240	217	1.2	38.000	12.000	300	14P32	natural	51
290	163	156	163	1.9	13.000	12.000	300	12L20	natural	51

6.2.1

MPR planetary geared motors



Technical data

Selection tables

2-stage gearboxes

Inverter operation						i	Product		Cooling	
M _{2, max} [Nm]	n _{2, th} [r/min]	M ₂ [Nm]	n _{2, eto} [r/min]	c	J [kgcm ²]		MPR	MCS		
290	138	191	138	1.5	13.000	12.000	300	12L17	forced	60
290	125	105	125	2.8	11.000	12.000	300	14D15	natural	51
290	125	116	125	2.5	10.000	12.000	300	12H15	natural	51
290	125	181	125	1.6	17.000	12.000	300	14H15	natural	51
290	125	261	125	1.1	27.000	12.000	300	14L15	natural	51
290	113	137	113	2.1	11.000	12.000	300	14D14	forced	60
290	113	137	113	2.1	10.000	12.000	300	12H14	forced	60
290	100	272	100	1.1	17.000	12.000	300	14H12	forced	60
336	145	113	145	3.4	6.300	20.000	300	12D35	forced	60
336	83	132	83	3.0	6.300	20.000	300	12D17	forced	60
342	145	81	145	4.8	6.300	20.000	300	12D41	natural	51
342	98	102	98	3.8	6.300	20.000	300	12D20	natural	51
380	46	282	46	1.4	6.100	70.000	300	12D41	natural	51
380	28	358	28	1.1	6.100	70.000	300	12D20	natural	51
390	181	113	181	3.5	11.000	16.000	300	14D36	natural	51
390	181	115	181	3.4	9.800	16.000	300	12H35	natural	51
390	181	121	181	3.2	9.800	16.000	300	12H30	natural	51
390	181	159	181	2.5	9.800	16.000	300	12H34	forced	60
390	181	160	181	2.4	11.000	16.000	300	14D30	forced	60
390	181	168	181	2.3	13.000	16.000	300	12L41	natural	51
390	181	212	181	1.8	13.000	16.000	300	12L39	forced	60
390	181	212	181	1.8	17.000	16.000	300	14H32	natural	51
390	181	261	181	1.5	26.000	16.000	300	14L32	natural	51
390	181	319	181	1.2	70.000	16.000	300	19F30	natural	51
390	181	320	181	1.2	38.000	16.000	300	14P32	natural	51
390	181	387	181	1.0	26.000	16.000	300	14L30	forced	60
390	173	314	173	1.2	17.000	16.000	300	14H28	forced	60
390	145	141	145	2.8	11.000	20.000	300	14D36	natural	51
390	145	144	145	2.7	9.600	20.000	300	12H35	natural	51
390	145	151	145	2.6	9.600	20.000	300	12H30	natural	51
390	145	199	145	2.0	9.600	20.000	300	12H34	forced	60
390	145	200	145	1.9	11.000	20.000	300	14D30	forced	60
390	145	211	145	1.9	13.000	20.000	300	12L41	natural	51
390	145	264	145	1.5	17.000	20.000	300	14H32	natural	51
390	145	265	145	1.5	13.000	20.000	300	12L39	forced	60
390	145	326	145	1.2	26.000	20.000	300	14L32	natural	51
390	122	208	122	1.9	13.000	16.000	300	12L20	natural	51
390	116	101	116	3.9	6.200	25.000	300	12D41	natural	51
390	116	142	116	2.8	6.200	25.000	300	12D35	forced	60
390	116	176	116	2.2	11.000	25.000	300	14D36	natural	51

6.2.1

MPR planetary geared motors



Technical data

Selection tables

2-stage gearboxes

Inverter operation						i	Product		Cooling	
M _{2, max} [Nm]	n _{2, th} [r/min]	M ₂ [Nm]	n _{2, eto} [r/min]	c	J [kgcm ²]		MPR	MCS		
390	116	180	116	2.2	9.500	25.000	300	12H35	natural	51
390	116	189	116	2.1	9.500	25.000	300	12H30	natural	51
390	116	249	116	1.6	11.000	25.000	300	14D30	forced	60
390	116	249	116	1.6	9.500	25.000	300	12H34	forced	60
390	116	263	116	1.5	13.000	25.000	300	12L41	natural	51
390	116	331	116	1.2	13.000	25.000	300	12L39	forced	60
390	116	331	116	1.2	17.000	25.000	300	14H32	natural	51
390	104	113	104	3.5	6.100	28.000	300	12D41	natural	51
390	104	159	104	2.5	6.100	28.000	300	12D35	forced	60
390	104	198	104	2.0	11.000	28.000	300	14D36	natural	51
390	104	202	104	1.9	9.400	28.000	300	12H35	natural	51
390	104	212	104	1.8	9.400	28.000	300	12H30	natural	51
390	104	278	104	1.4	9.400	28.000	300	12H34	forced	60
390	104	279	104	1.4	11.000	28.000	300	14D30	forced	60
390	104	295	104	1.3	13.000	28.000	300	12L41	natural	51
390	104	370	104	1.1	17.000	28.000	300	14H32	natural	51
390	104	371	104	1.1	13.000	28.000	300	12L39	forced	60
390	103	255	103	1.5	13.000	16.000	300	12L17	forced	60
390	98	261	98	1.5	13.000	20.000	300	12L20	natural	51
390	94	140	94	2.8	11.000	16.000	300	14D15	natural	51
390	94	155	94	2.5	9.800	16.000	300	12H15	natural	51
390	94	242	94	1.6	17.000	16.000	300	14H15	natural	51
390	94	348	94	1.1	26.000	16.000	300	14L15	natural	51
390	84	183	84	2.1	11.000	16.000	300	14D14	forced	60
390	84	183	84	2.1	9.800	16.000	300	12H14	forced	60
390	83	141	83	2.8	6.100	35.000	300	12D41	natural	51
390	83	198	83	2.0	6.100	35.000	300	12D35	forced	60
390	83	247	83	1.6	11.000	35.000	300	14D36	natural	51
390	83	252	83	1.6	9.400	35.000	300	12H35	natural	51
390	83	265	83	1.5	9.400	35.000	300	12H30	natural	51
390	83	319	83	1.2	13.000	20.000	300	12L17	forced	60
390	83	348	83	1.1	9.400	35.000	300	12H34	forced	60
390	83	349	83	1.1	11.000	35.000	300	14D30	forced	60
390	83	368	83	1.1	13.000	35.000	300	12L41	natural	51
390	78	128	78	3.0	6.200	25.000	300	12D20	natural	51
390	78	326	78	1.2	13.000	25.000	300	12L20	natural	51
390	75	175	75	2.2	11.000	20.000	300	14D15	natural	51
390	75	194	75	2.0	9.600	20.000	300	12H15	natural	51
390	75	302	75	1.3	17.000	20.000	300	14H15	natural	51
390	75	363	75	1.1	17.000	16.000	300	14H12	forced	60

6.2.1

MPR planetary geared motors

Technical data



Selection tables

2-stage gearboxes

Inverter operation						i	Product		Cooling	
M _{2, max} [Nm]	n _{2, th} [r/min]	M ₂ [Nm]	n _{2, eto} [r/min]	c	J [kgcm ²]		MPR	MCS		
390	73	161	73	2.4	6.100	40.000	300	12D41	natural	51
390	73	226	73	1.7	6.100	40.000	300	12D35	forced	60
390	73	282	73	1.4	11.000	40.000	300	14D36	natural	51
390	73	288	73	1.4	9.400	40.000	300	12H35	natural	51
390	73	302	73	1.3	9.400	40.000	300	12H30	natural	51
390	70	143	70	2.7	6.100	28.000	300	12D20	natural	51
390	70	365	70	1.1	13.000	28.000	300	12L20	natural	51
390	68	228	68	1.7	11.000	20.000	300	14D14	forced	60
390	68	228	68	1.7	9.600	20.000	300	12H14	forced	60
390	66	165	66	2.4	6.200	25.000	300	12D17	forced	60
390	64	202	64	1.9	6.100	50.000	300	12D41	natural	51
390	64	283	64	1.4	6.100	50.000	300	12D35	forced	60
390	64	360	64	1.1	9.400	50.000	300	12H35	natural	51
390	60	219	60	1.8	11.000	25.000	300	14D15	natural	51
390	60	242	60	1.6	9.500	25.000	300	12H15	natural	51
390	60	378	60	1.0	17.000	25.000	300	14H15	natural	51
390	60	378	60	1.0	9.400	50.000	300	12H30	natural	51
390	59	185	59	2.1	6.100	28.000	300	12D17	forced	60
390	58	353	58	1.1	11.000	50.000	300	14D36	natural	51
390	56	179	56	2.2	6.100	35.000	300	12D20	natural	51
390	54	246	54	1.6	11.000	28.000	300	14D15	natural	51
390	54	271	54	1.4	9.400	28.000	300	12H15	natural	51
390	54	286	54	1.4	11.000	25.000	300	14D14	forced	60
390	54	286	54	1.4	9.500	25.000	300	12H14	forced	60
390	49	205	49	1.9	6.100	40.000	300	12D20	natural	51
390	48	320	48	1.2	11.000	28.000	300	14D14	forced	60
390	48	320	48	1.2	9.400	28.000	300	12H14	forced	60
390	47	231	47	1.7	6.100	35.000	300	12D17	forced	60
390	43	307	43	1.3	11.000	35.000	300	14D15	natural	51
390	43	339	43	1.1	9.400	35.000	300	12H15	natural	51
390	41	264	41	1.5	6.100	40.000	300	12D17	forced	60
390	39	256	39	1.5	6.100	50.000	300	12D20	natural	51
390	38	351	38	1.1	11.000	40.000	300	14D15	natural	51
390	38	387	38	1.0	9.400	40.000	300	12H15	natural	51
390	33	330	33	1.2	6.100	50.000	300	12D17	forced	60

6.2.1

MPR planetary geared motors

Technical data



Dimensions, notes

Notes on the dimensions

The following legend shows the layout of the dimension sheets.

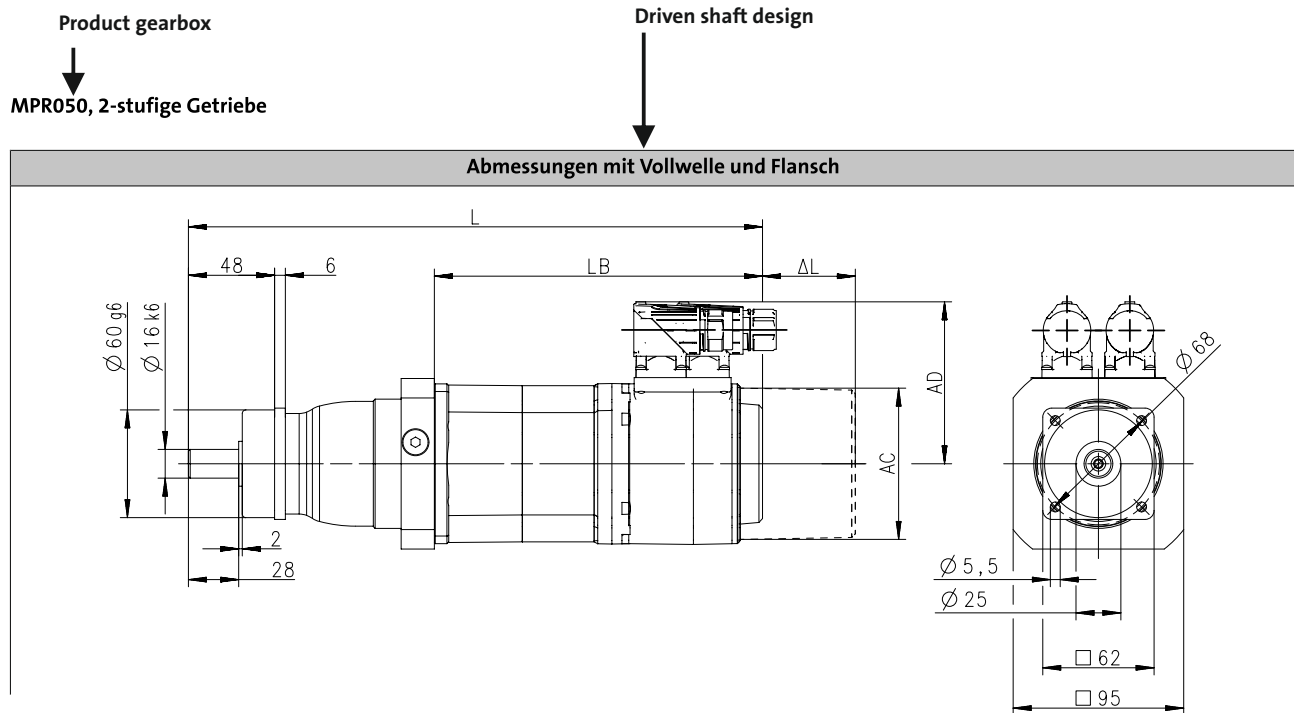

Product Motor

Produkt			MCS						
			06C41	06C60	06F41	06F60	06I41	06I60	09D60
Länge									
Gesamtlänge	L	[mm]	298			328		358	349
Länge Motor	LB	[mm]	182			162		192	183
Länge Motoranbauten	ΔL	[mm]			100				71
Motordurchmesser	AC	[mm]				86			89
Abstand Motor/Anschluss	AD	[mm]				77			89.7

Distance of motor centre to the end of connector

Total length of the drive without built-on accessories

Motor diameter

Motor length without built-on accessories

Additional length of the built-on accessories (longest version)

6.2.1

MPR planetary geared motors

Technical data



Dimensions, self-ventilated motors

MPR0501-stage gearboxes

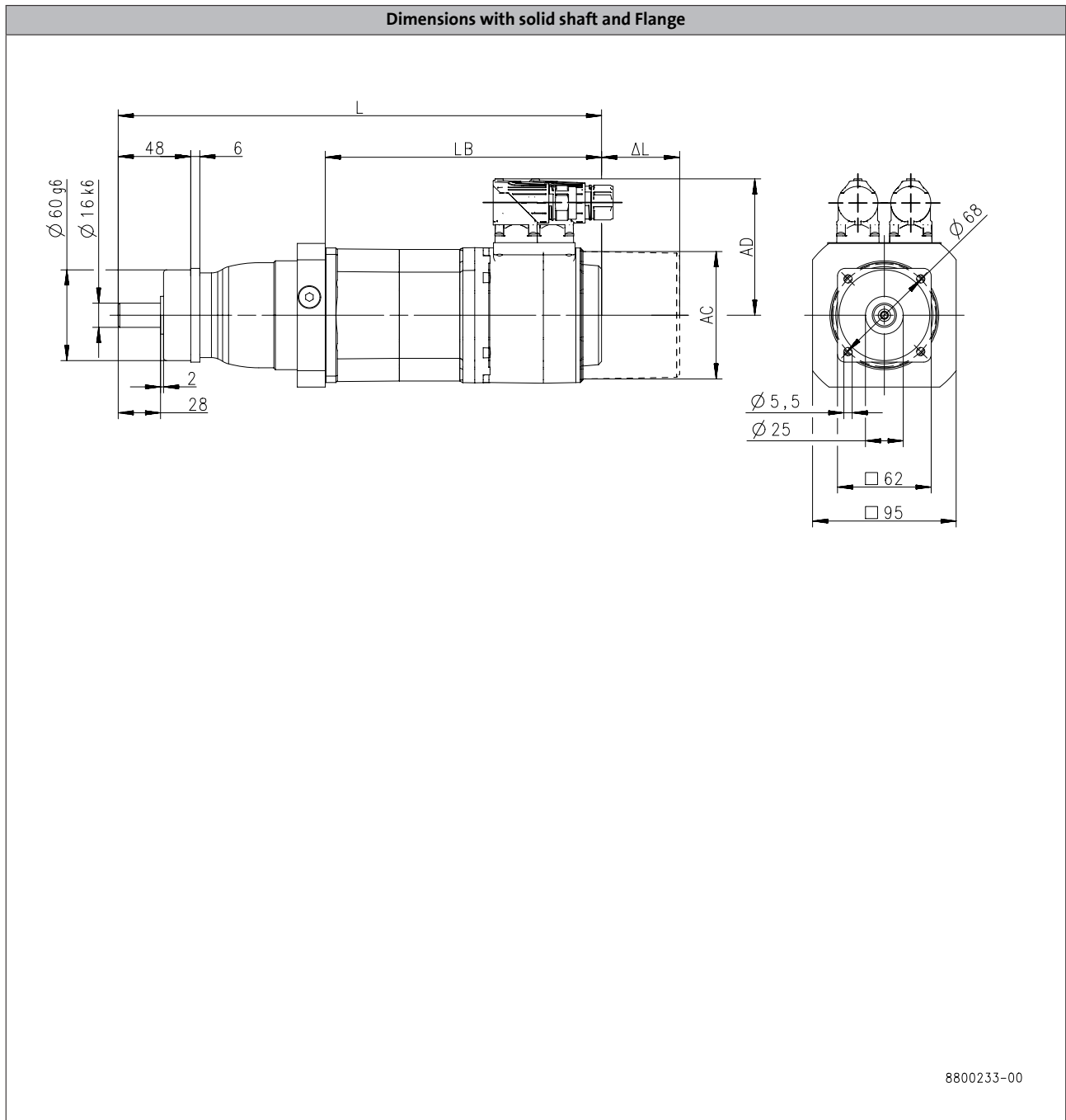

Product			MCS							
			06C41	06C60	06F41	06F60	06I41	06I60	09D41	09D60
Length										
Total length	L	[mm]	269		299			329		320
Motor length	LB	[mm]	132		162			192		183
Length of motor options	Δ L	[mm]			100					71
Motor diameter	AC	[mm]			86					89
Distance motor/connection	AD	[mm]			77					89.7

MPR planetary geared motors

Technical data



Dimensions, self-ventilated motors

MPR0501-stage gearboxes

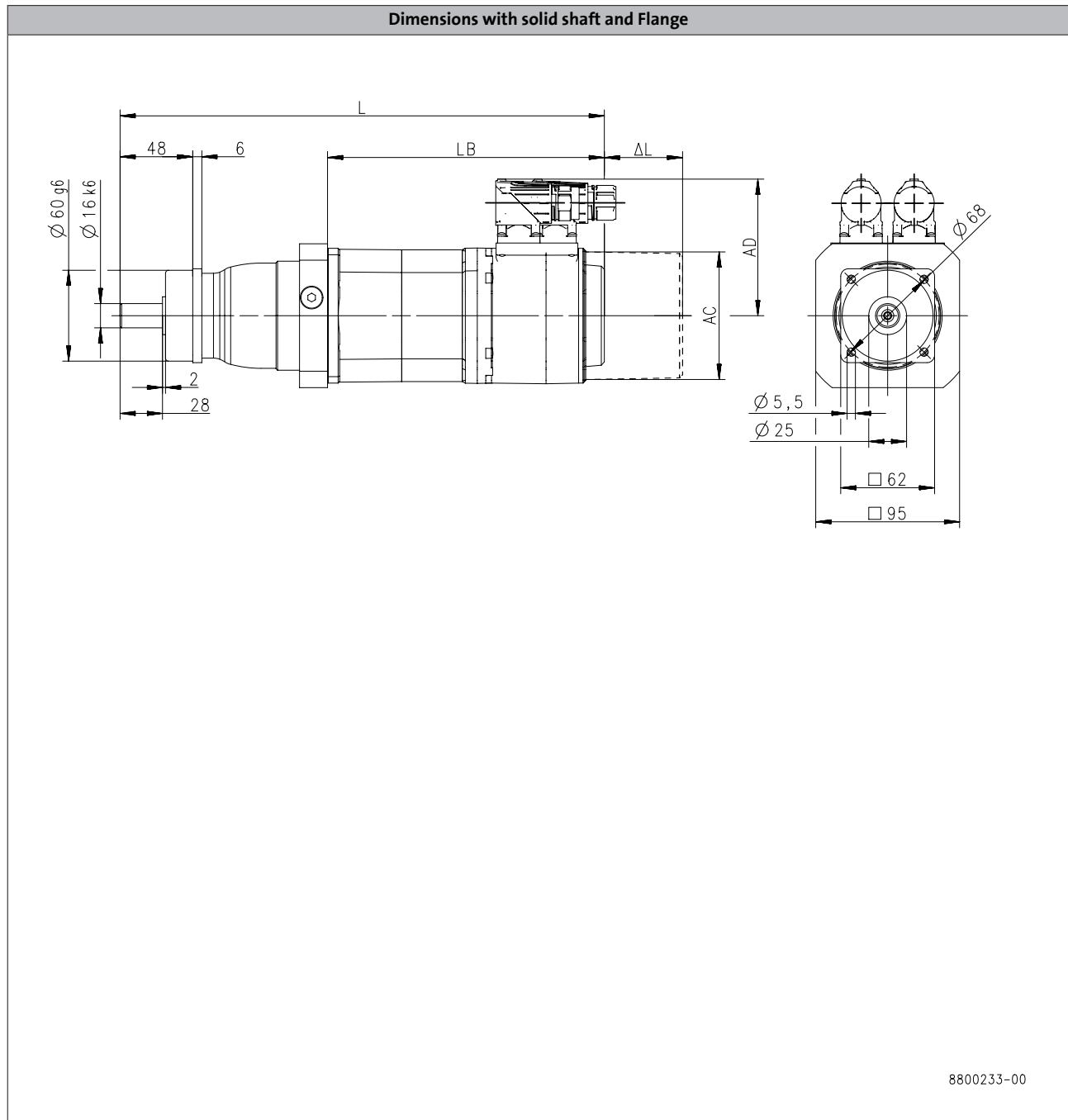

6.2.1

Product			MCS							
			09F38	09F60	09H41	09H60	09L41	09L51	12D20	12D41
Length										
Total length	L	[mm]	340		360		400		334	
Motor length	LB	[mm]	203		223		263		188	
Length of motor options	Δ L	[mm]			71				69	
Motor diameter	AC	[mm]			89				116	
Distance motor/connection	AD	[mm]			89.7				105	

MPR planetary geared motors

Technical data



Dimensions, self-ventilated motors

MPR050: 2-stage gearboxes

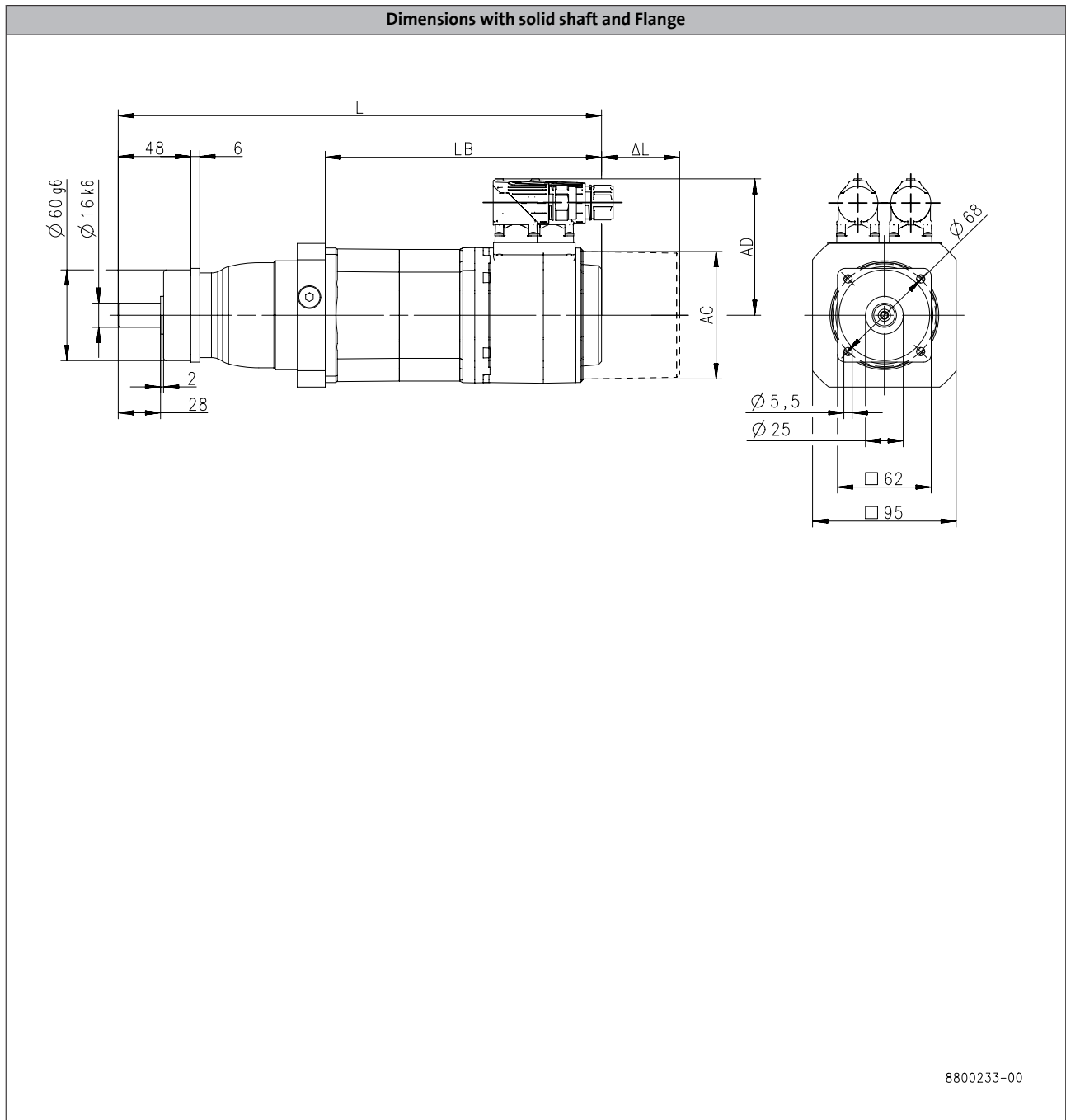

Product			MCS						
			06C41	06C60	06F41	06F60	06I41		06I60
Length									
Total length	L	[mm]	298		328		358		349
Motor length	LB	[mm]	132		162		192		183
Length of motor options	Δ L	[mm]			100				71
Motor diameter	AC	[mm]			86				89
Distance motor/connection	AD	[mm]			77				89.7

MPR planetary geared motors

Technical data



Dimensions, self-ventilated motors

MPR100, 1-stage gearboxes

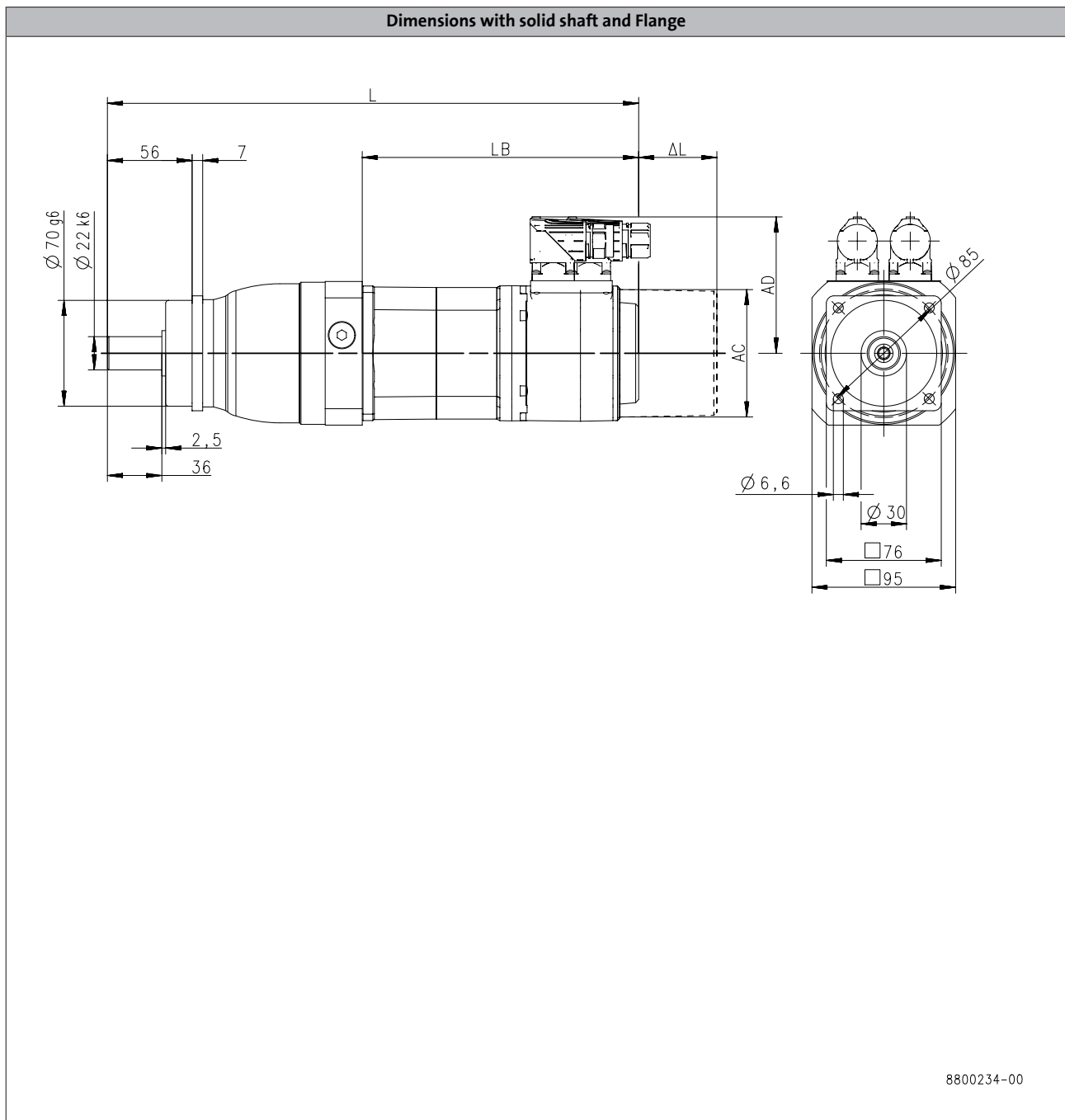

6.2.1

Product			MCS							
			09D41	09D60	09F38	09F60	09H41	09H60	09L41	09L51
Length										
Total length	L	[mm]	352		372		392		432	
Motor length	LB	[mm]	183		203		223		263	
Length of motor options	Δ L	[mm]	71							
Motor diameter	AC	[mm]	89							
Distance motor/connection	AD	[mm]	89.7							

MPR planetary geared motors

Technical data



Dimensions, self-ventilated motors

MPR100, 1-stage gearboxes

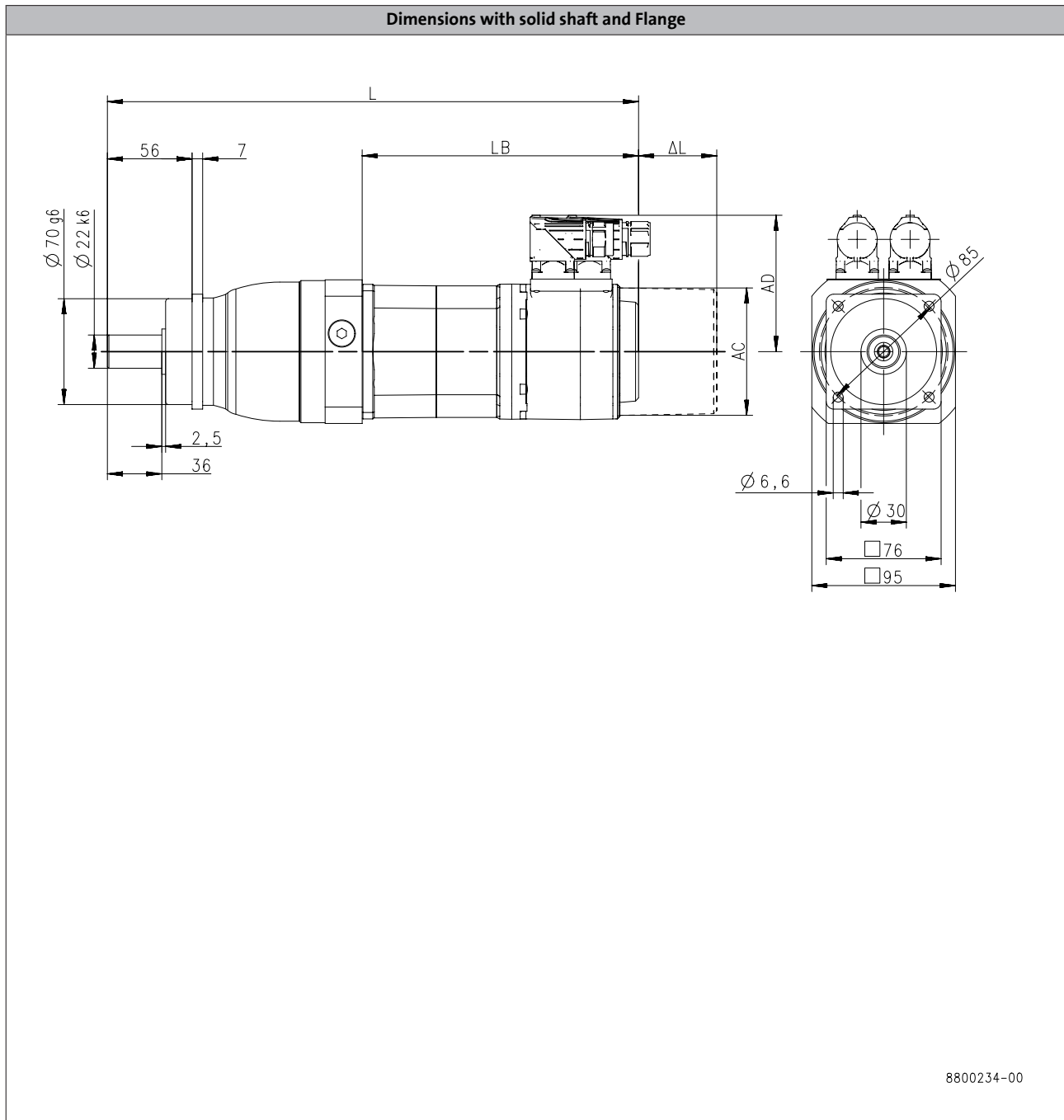

Product			MCS								
			12D20	12D41	12H15	12H30	12H35	12L20	12L41	14D15	14D36
Length											
Total length	L	[mm]	357			397			437		380
Motor length	LB	[mm]	188			228			268		201
Length of motor options	Δ L	[mm]				69					78
Motor diameter	AC	[mm]				116					143
Distance motor/connection	AD	[mm]				105					116.5

MPR planetary geared motors

Technical data



Dimensions, self-ventilated motors

MPR100: 2-stage gearboxes

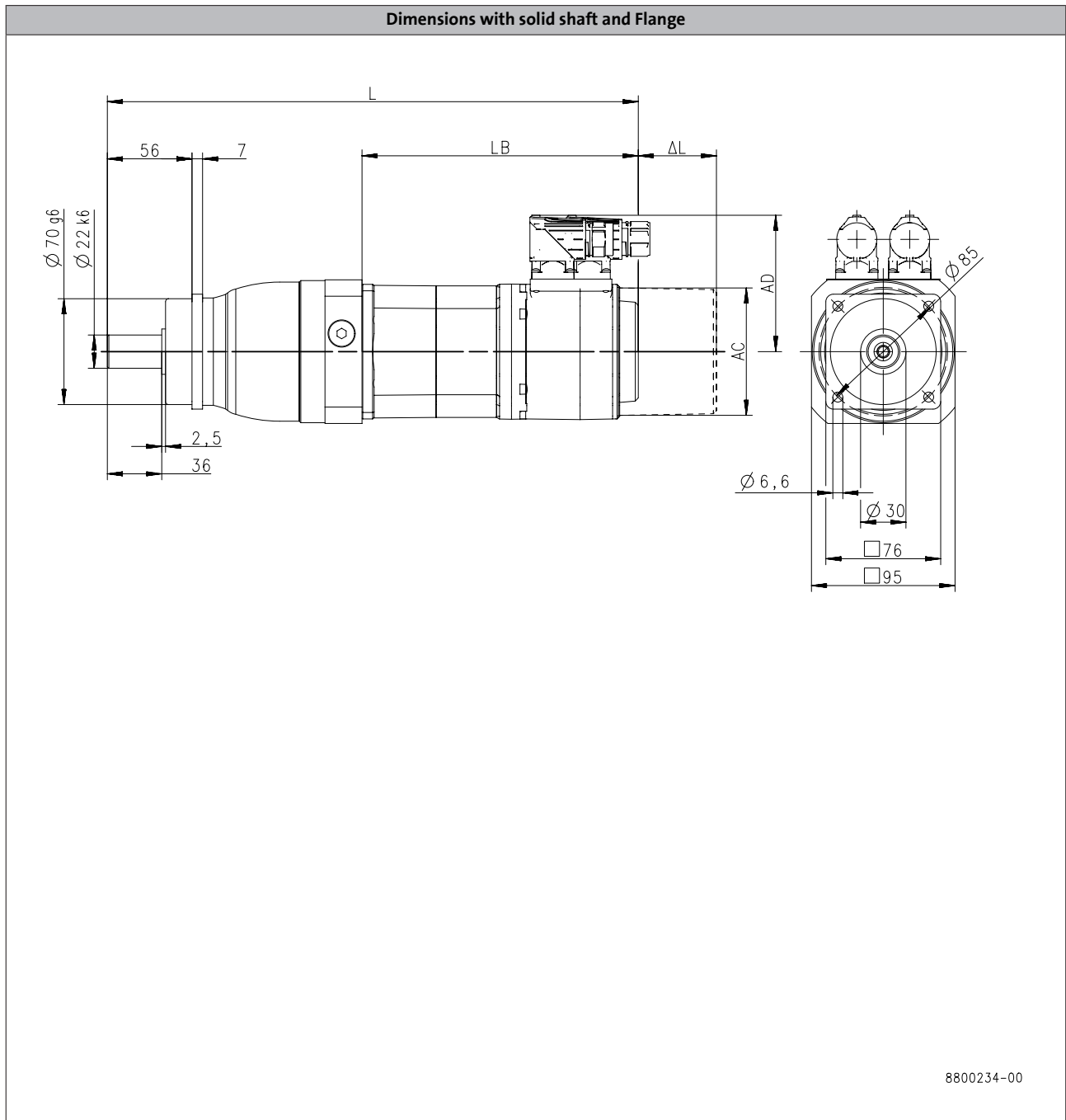

6.2.1

Product			MCS						
			06C41	06C60	06F41	06F60	06I41		06I60
Length									
Total length	L	[mm]	321		351		381		372
Motor length	LB	[mm]	132		162		192		183
Length of motor options	Δ L	[mm]			100				71
Motor diameter	AC	[mm]			86				89
Distance motor/connection	AD	[mm]			77				89.7

MPR planetary geared motors

Technical data



Dimensions, self-ventilated motors

MPR100: 2-stage gearboxes

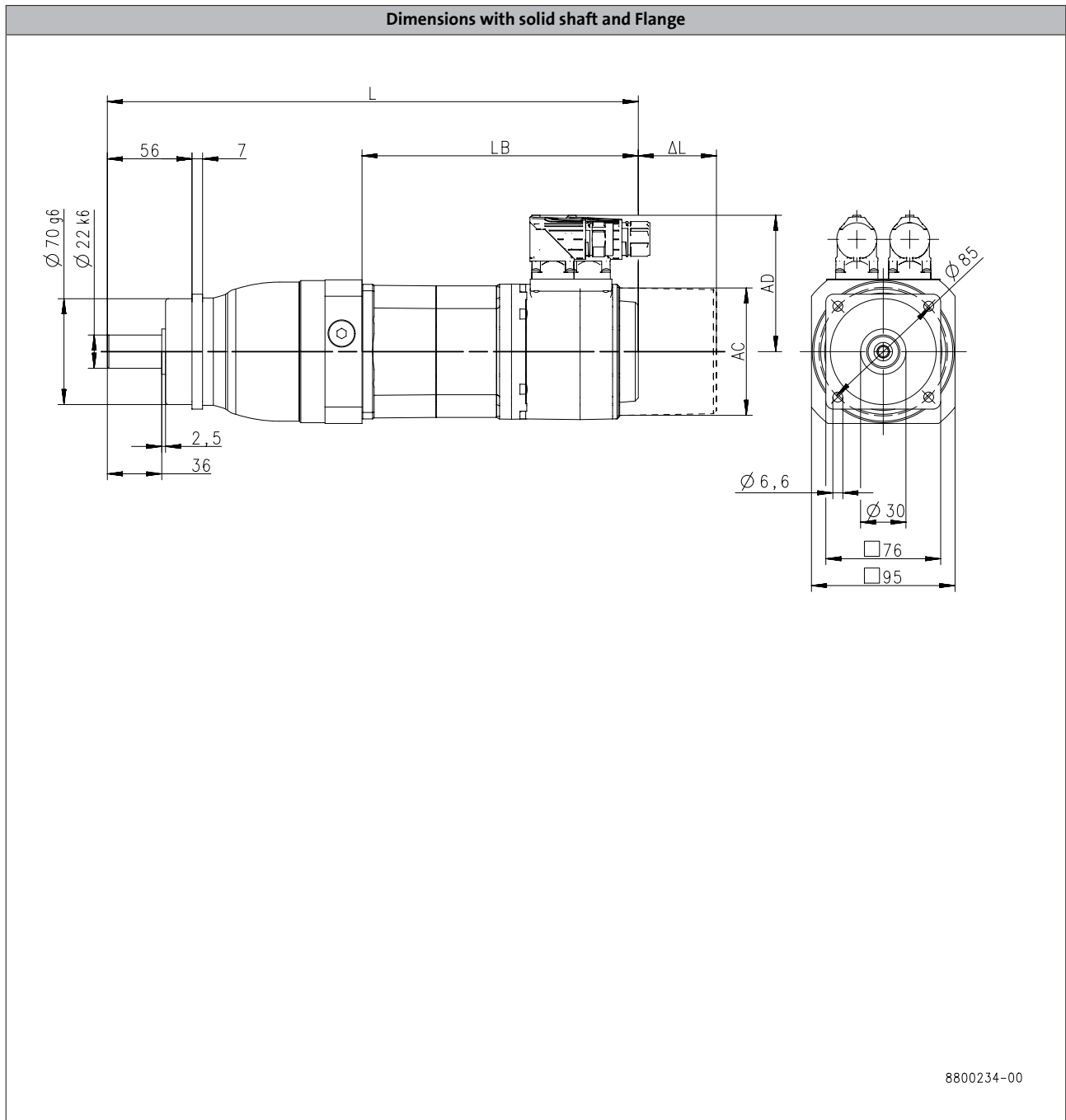

8800234-00

Product			MCS							
			09D60	09F38	09F60	09H41	09H60	09L41	09L51	
Length										
Total length	L	[mm]	372	392		412		452		
Motor length	LB	[mm]	183	203		223		263		
Length of motor options	ΔL	[mm]				71				
Motor diameter	AC	[mm]				89				
Distance motor/connection	AD	[mm]				89.7				

MPR planetary geared motors

Technical data



Dimensions, self-ventilated motors

MPR200, 1-stage gearboxes

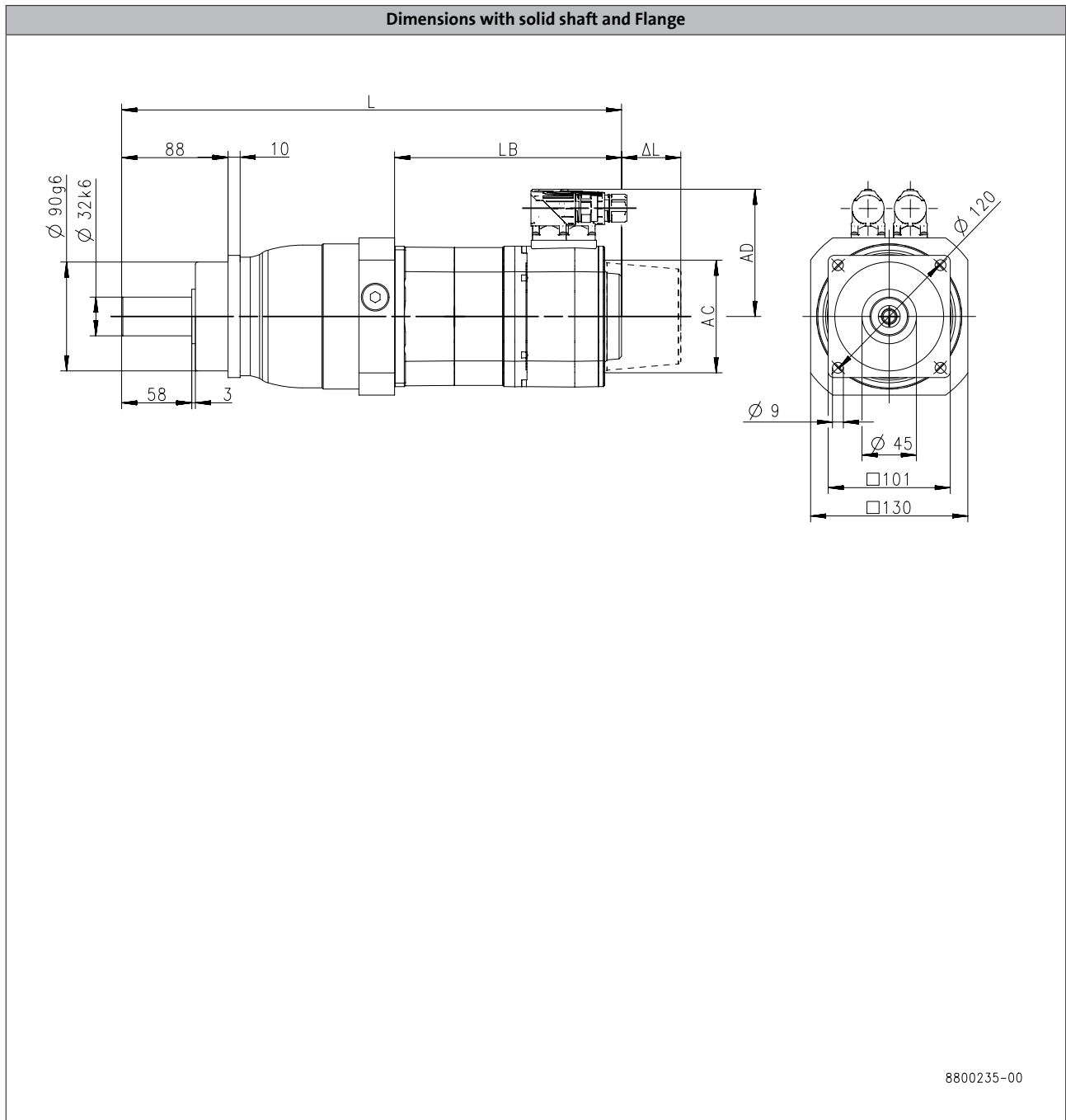

6.2.1

Product			MCS								
			12D20	12D41	12H15	12H30	12H35	12L20	12L41	14D15	14D36
Length											
Total length	L	[mm]	414			454			494		427
Motor length	LB	[mm]	188			228			268		201
Length of motor options	Δ L	[mm]				69					78
Motor diameter	AC	[mm]				116					143
Distance motor/connection	AD	[mm]				105					116.5

MPR planetary geared motors

Technical data



Dimensions, self-ventilated motors

MPR200, 1-stage gearboxes

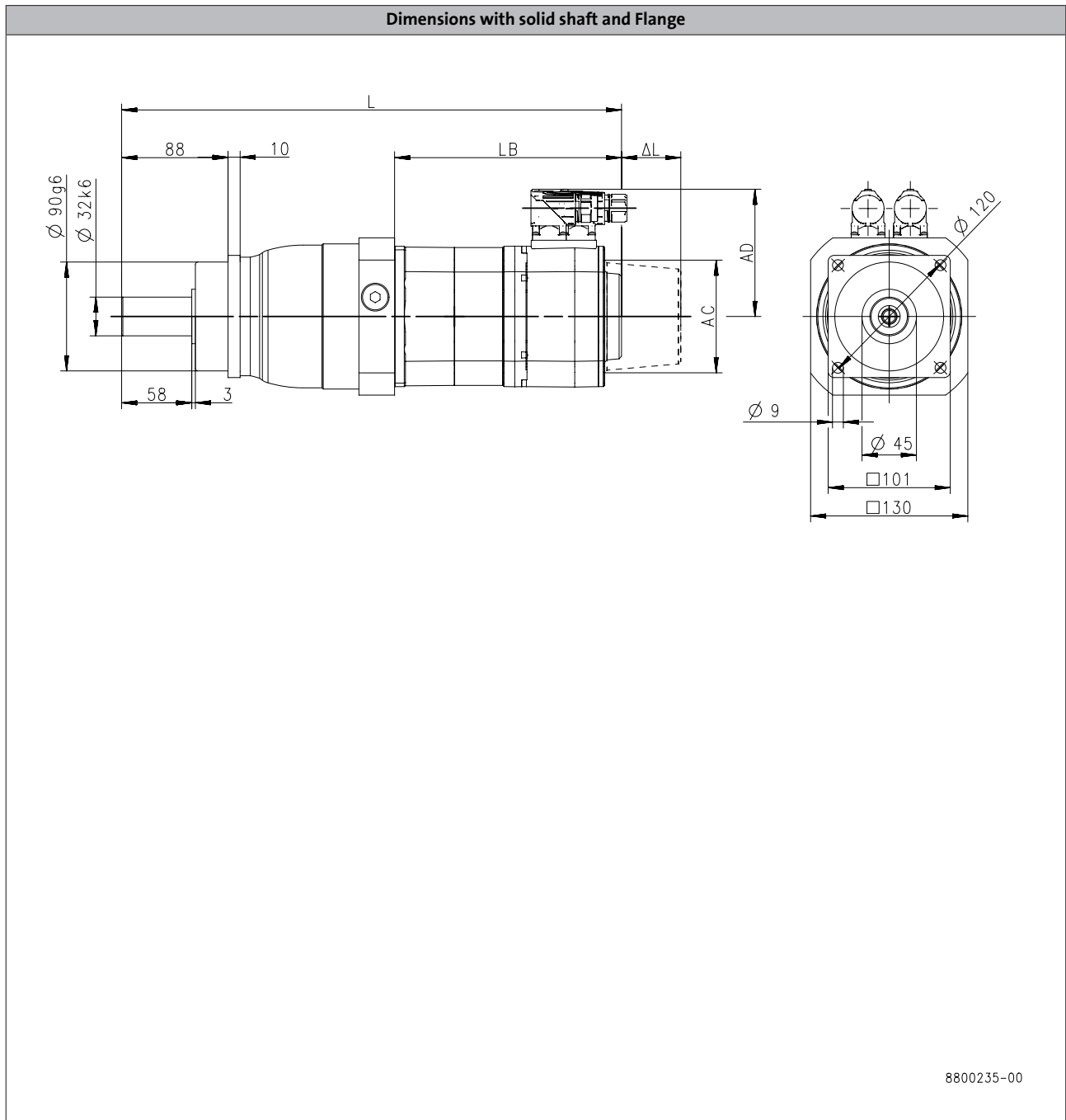

Product			MCS									
			14H15	14H32	14L15	14L32	14P14	14P32	19F14	19F30	19J14	19J30
Length												
Total length	L	[mm]	467		507		547		446		486	
Motor length	LB	[mm]	241		281		321		220		260	
Length of motor options	Δ L	[mm]			78				83		93	
Motor diameter	AC	[mm]			143				192			
Distance motor/connection	AD	[mm]	116.5		146		116.5	146	141.5	171	141.5	171

MPR planetary geared motors

Technical data



Dimensions, self-ventilated motors

MPR200, 2-stage gearboxes

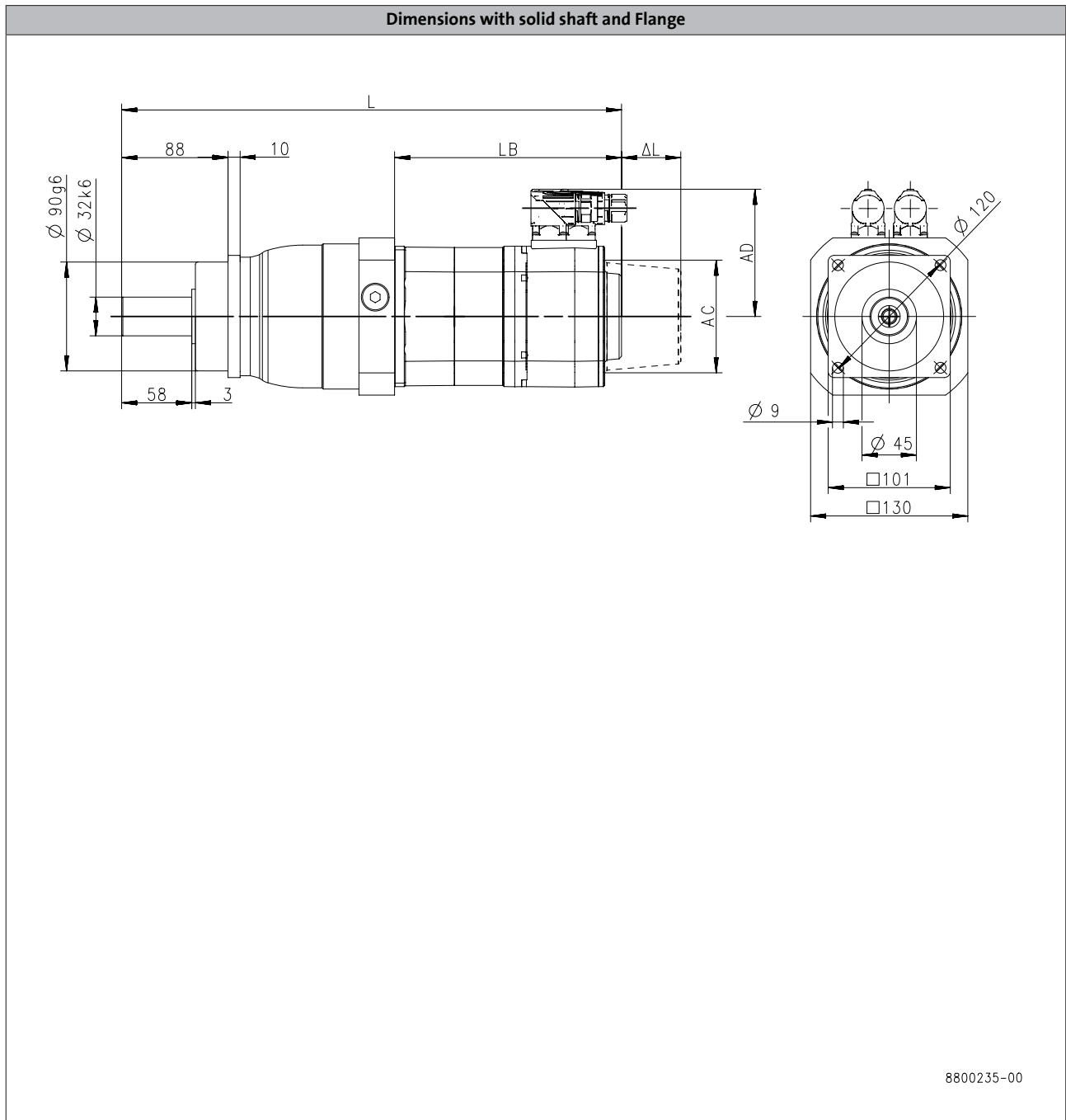

6.2.1

Product			MCS						
			09D41	09D60	09F38	09F60	09H41	09H60	09L41
Length									
Total length	L	[mm]	423		443		463		503
Motor length	LB	[mm]	183		203		223		263
Length of motor options	ΔL	[mm]			71				
Motor diameter	AC	[mm]			89				
Distance motor/connection	AD	[mm]			89.7				

MPR planetary geared motors

Technical data



Dimensions, self-ventilated motors

MPR200, 2-stage gearboxes

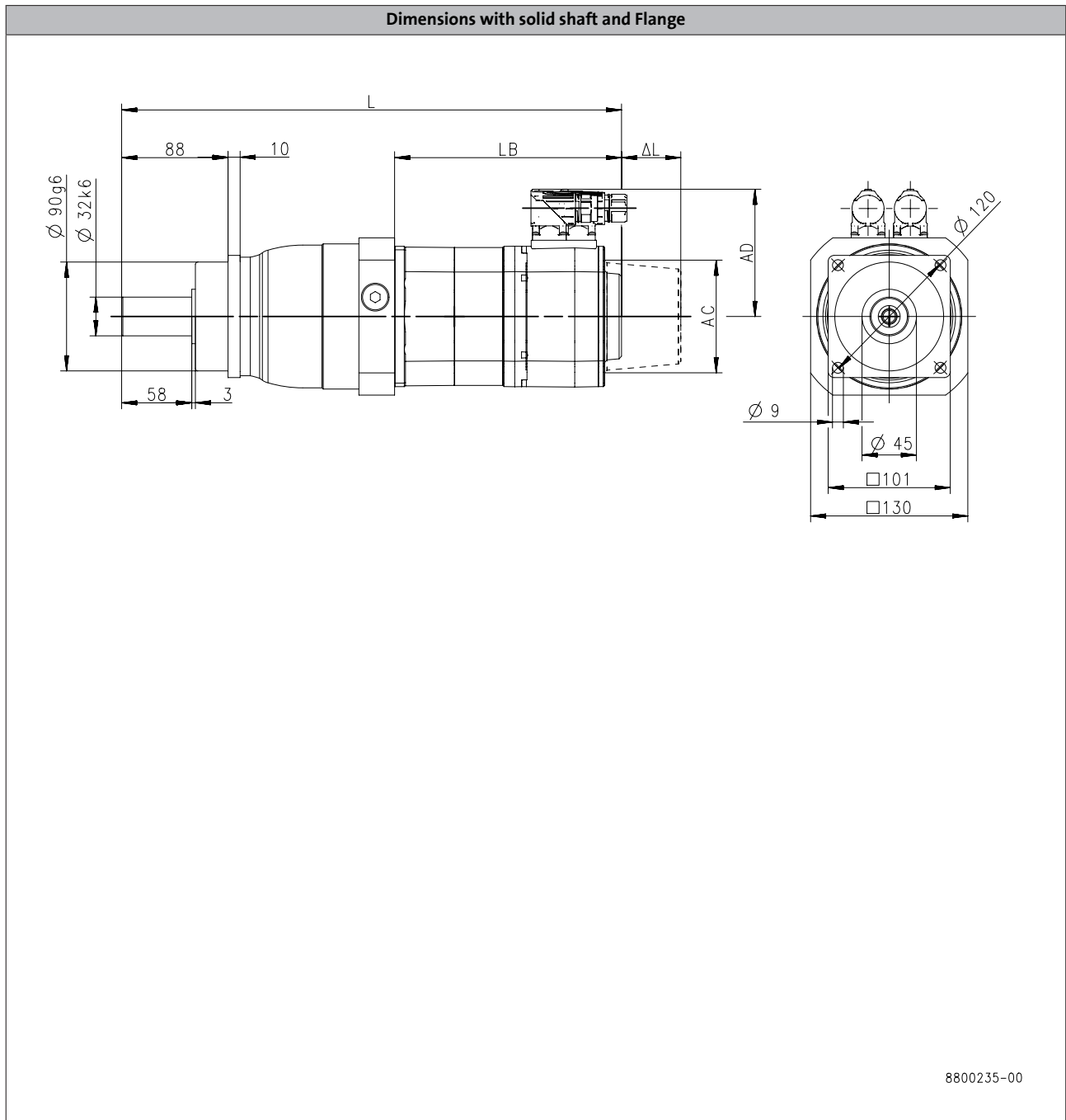

Product			MCS						
			09L51	12D20	12D41	12H15	12H30	12H35	12L41
Length									
Total length	L	[mm]	503	428			468		508
Motor length	LB	[mm]	263	188			228		268
Length of motor options	ΔL	[mm]	71			69			
Motor diameter	AC	[mm]	89			116			
Distance motor/connection	AD	[mm]	89.7			105			

MPR planetary geared motors

Technical data



Dimensions, self-ventilated motors

MPR300, 1-stage gearboxes

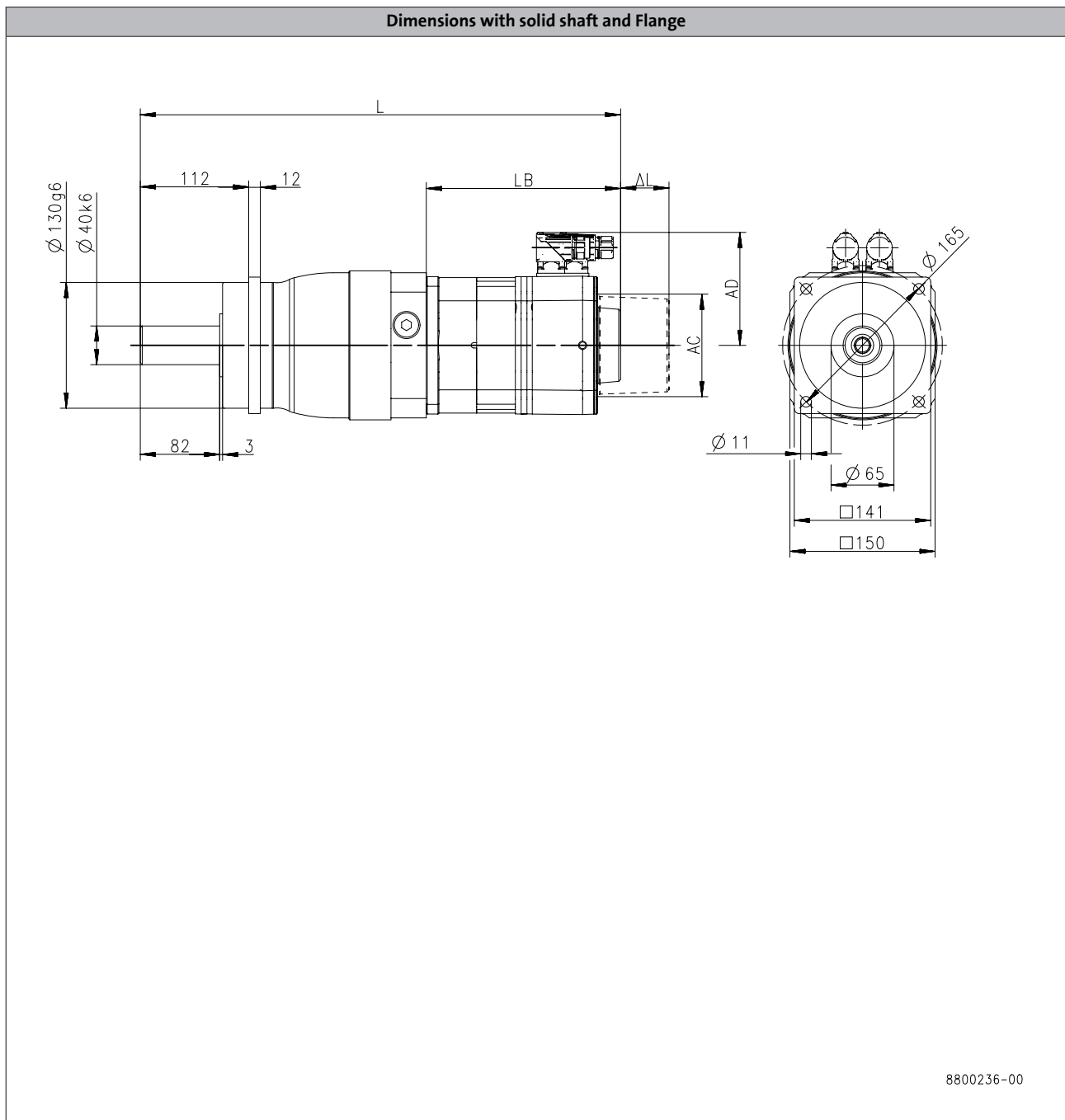

6.2.1

Product			MCS							
			14D15	14D36	14H15	14H32	14L15	14L32	14P14	
Length										
Total length	L	[mm]	497		537			577		617
Motor length	LB	[mm]	201		241			281		321
Length of motor options	ΔL	[mm]			78					
Motor diameter	AC	[mm]			143					
Distance motor/connection	AD	[mm]			116.5			146		116.5

MPR planetary geared motors

Technical data



Dimensions, self-ventilated motors

MPR300, 1-stage gearboxes

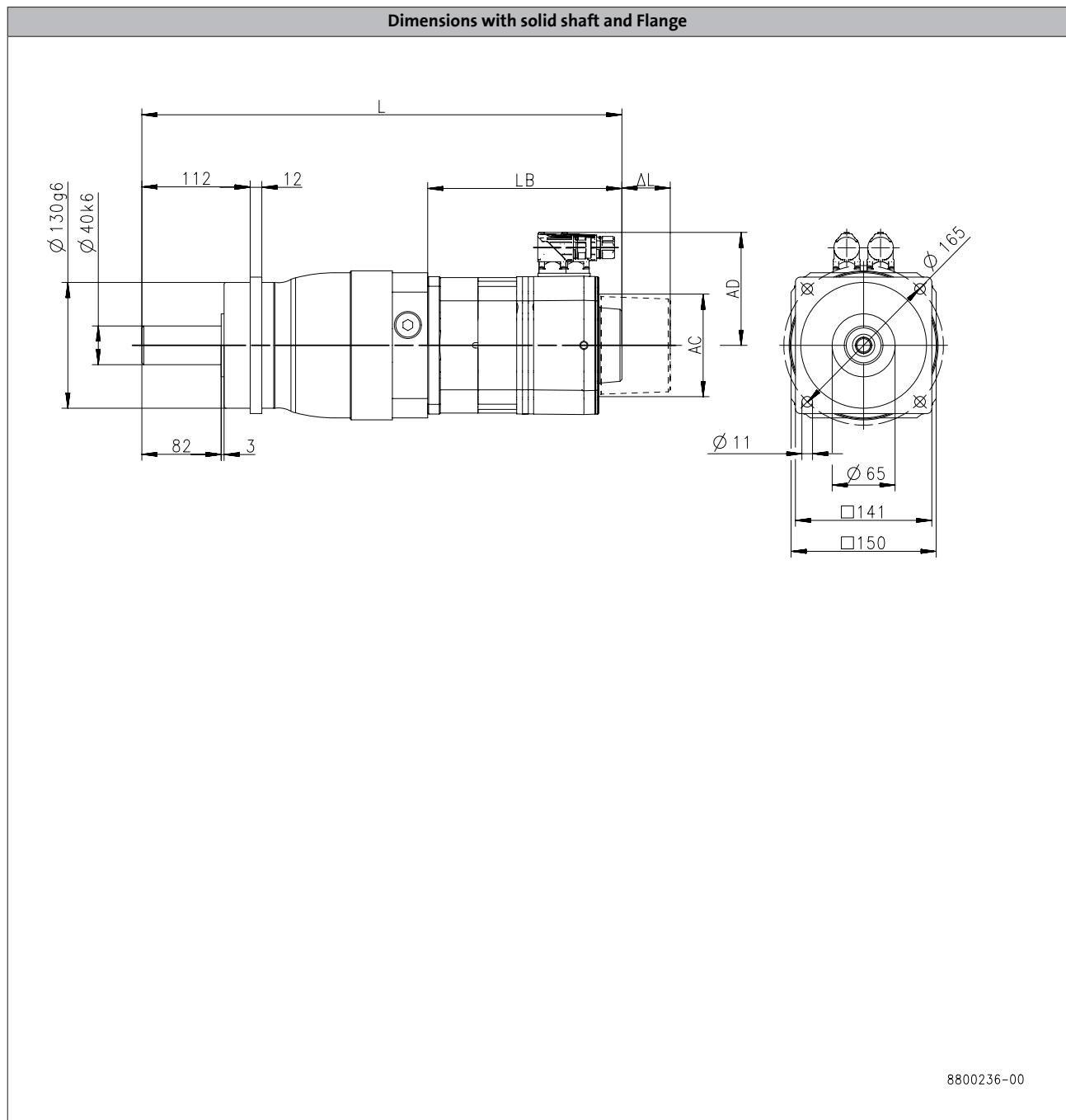

Product			MCS							
			14P32	19F14	19F30	19J14	19J30	19P14	19P30	
Length										
Total length	L	[mm]	617	516		556		616		
Motor length	LB	[mm]	321	220		260		320		
Length of motor options	Δ L	[mm]	78	83			93			
Motor diameter	AC	[mm]	143			192				
Distance motor/connection	AD	[mm]	146	141.5	171	141.5	171	141.5	171	

MPR planetary geared motors

Technical data



Dimensions, self-ventilated motors

MPR300, 2-stage gearboxes

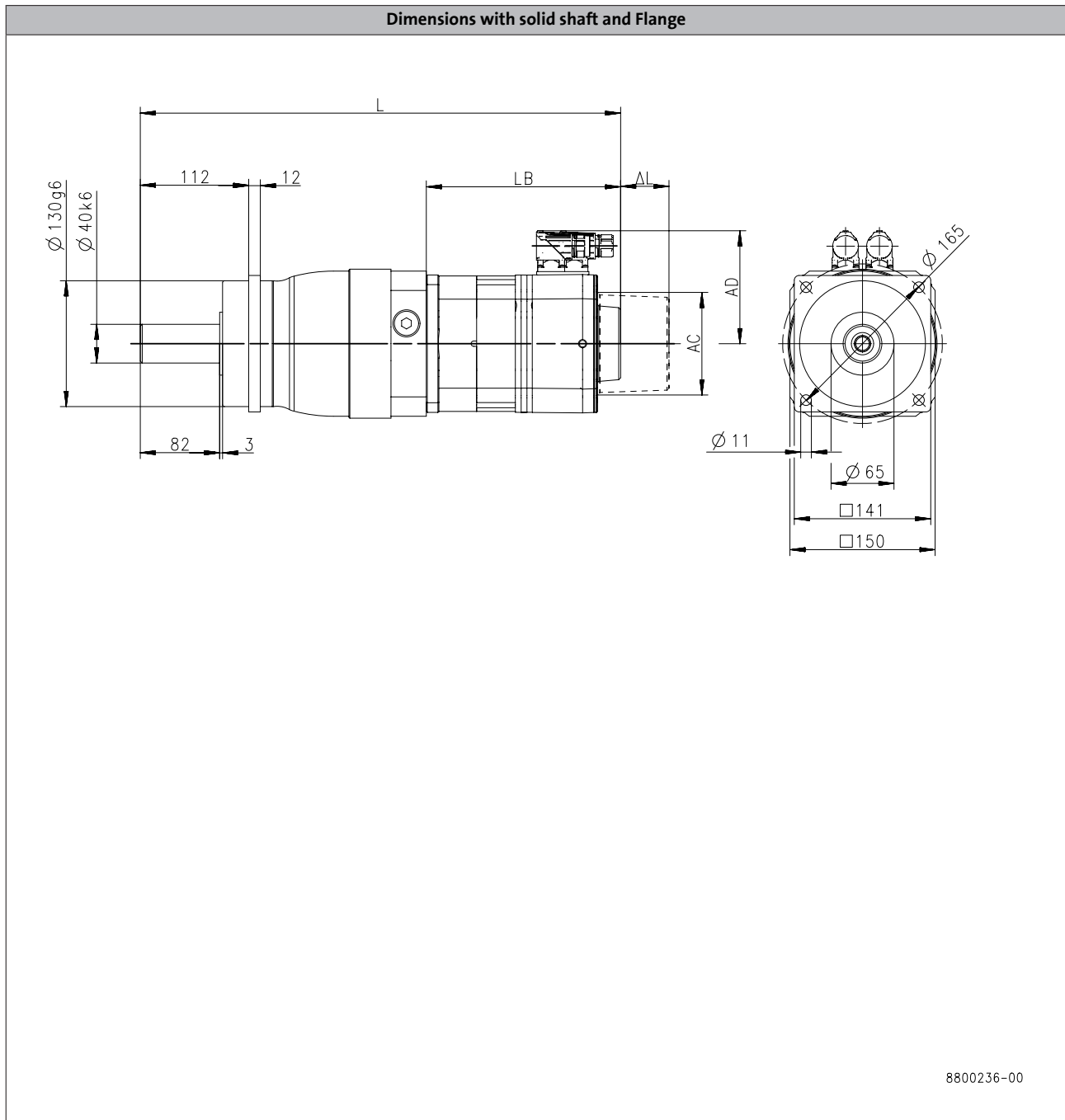

6.2.1

Product			MCS							
			12D20	12D41	12H15	12H30	12H35	12L20	12L41	
Length										
Total length	L	[mm]	502		542		582			
Motor length	LB	[mm]	188		228		268			
Length of motor options	Δ L	[mm]			69					
Motor diameter	AC	[mm]			116					
Distance motor/connection	AD	[mm]			105					

MPR planetary geared motors

Technical data



Dimensions, self-ventilated motors

MPR300, 2-stage gearboxes

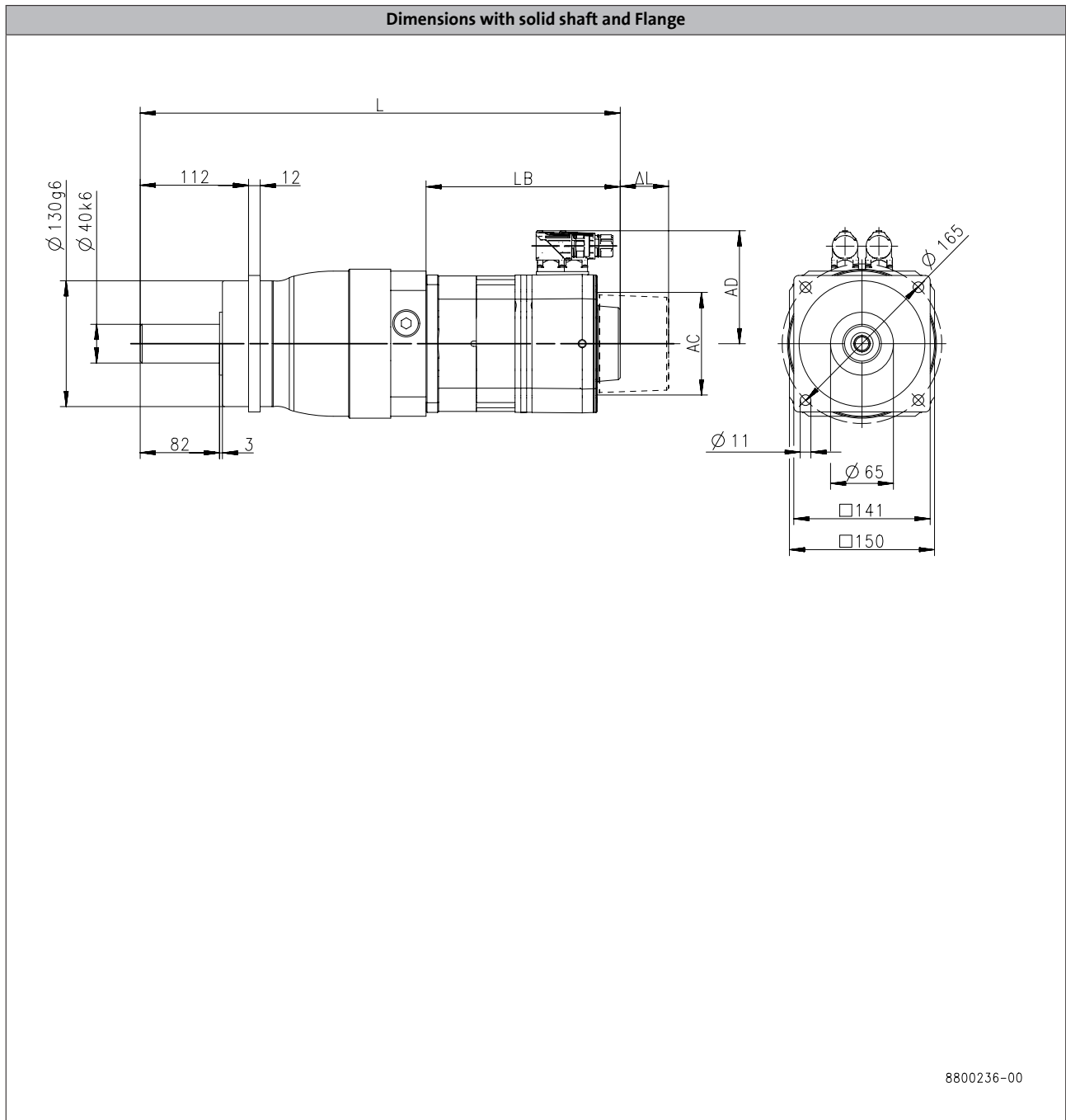

Product			MCS								
			14D15	14D36	14H15	14H32	14L15	14L32	14P32	19F30	
Length											
Total length	L	[mm]	515		555			595		635	534
Motor length	LB	[mm]	201		241			281		321	220
Length of motor options	ΔL	[mm]				78					83
Motor diameter	AC	[mm]				143					192
Distance motor/connection	AD	[mm]			116.5				146		171

MPR planetary geared motors

Technical data



Dimensions, forced ventilated motors

MPR0501-stage gearboxes

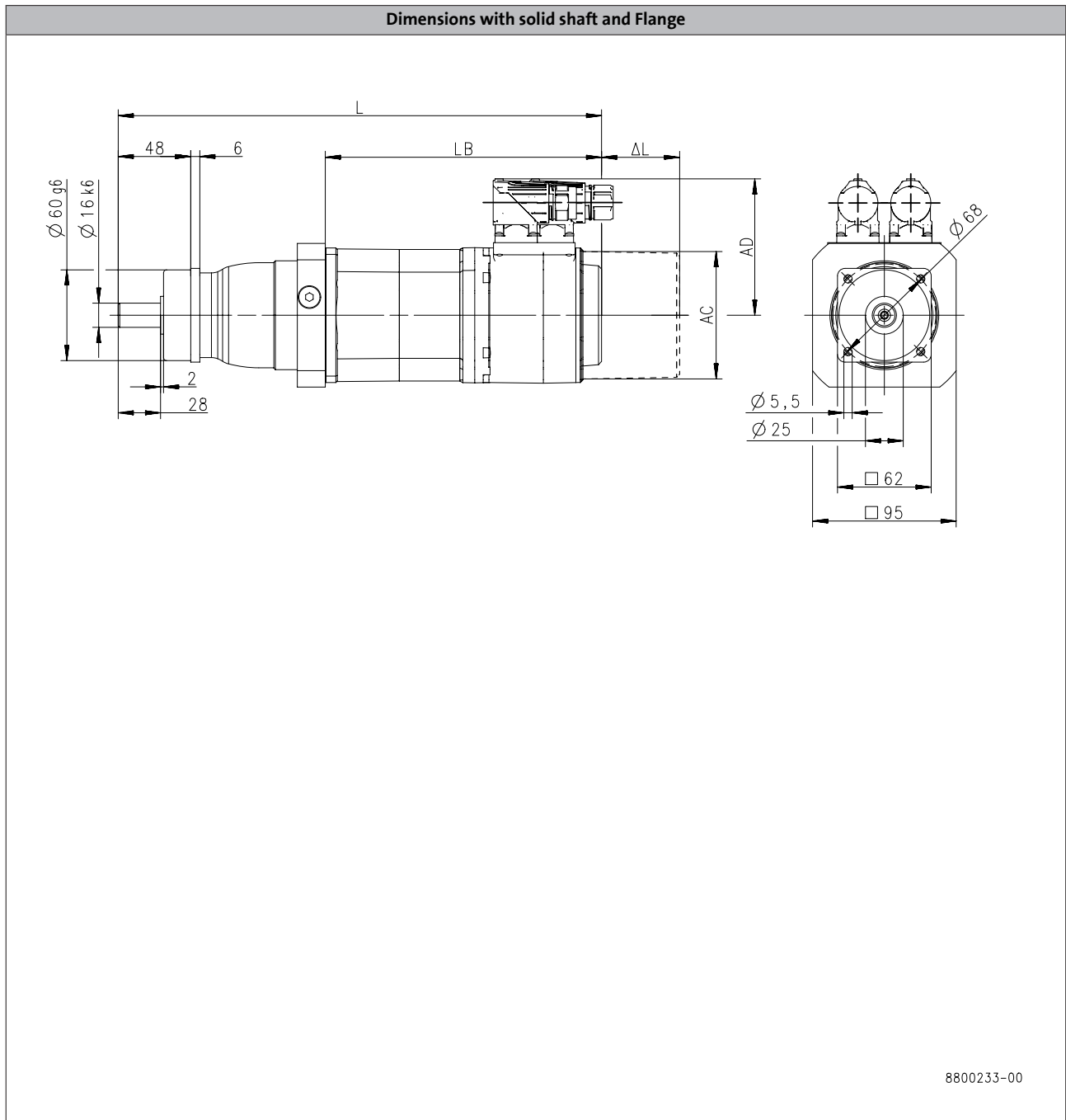

6.2.1

Product			MCS	
			12D17	12D35
Length				
Total length	L	[mm]	407	
Motor length	LB	[mm]	261	
Length of motor options	Δ L	[mm]	63	
Motor diameter	AC	[mm]	140	
Distance motor/connection	AD	[mm]	105	

MPR planetary geared motors

Technical data



Dimensions, forced ventilated motors

MPR100, 1-stage gearboxes

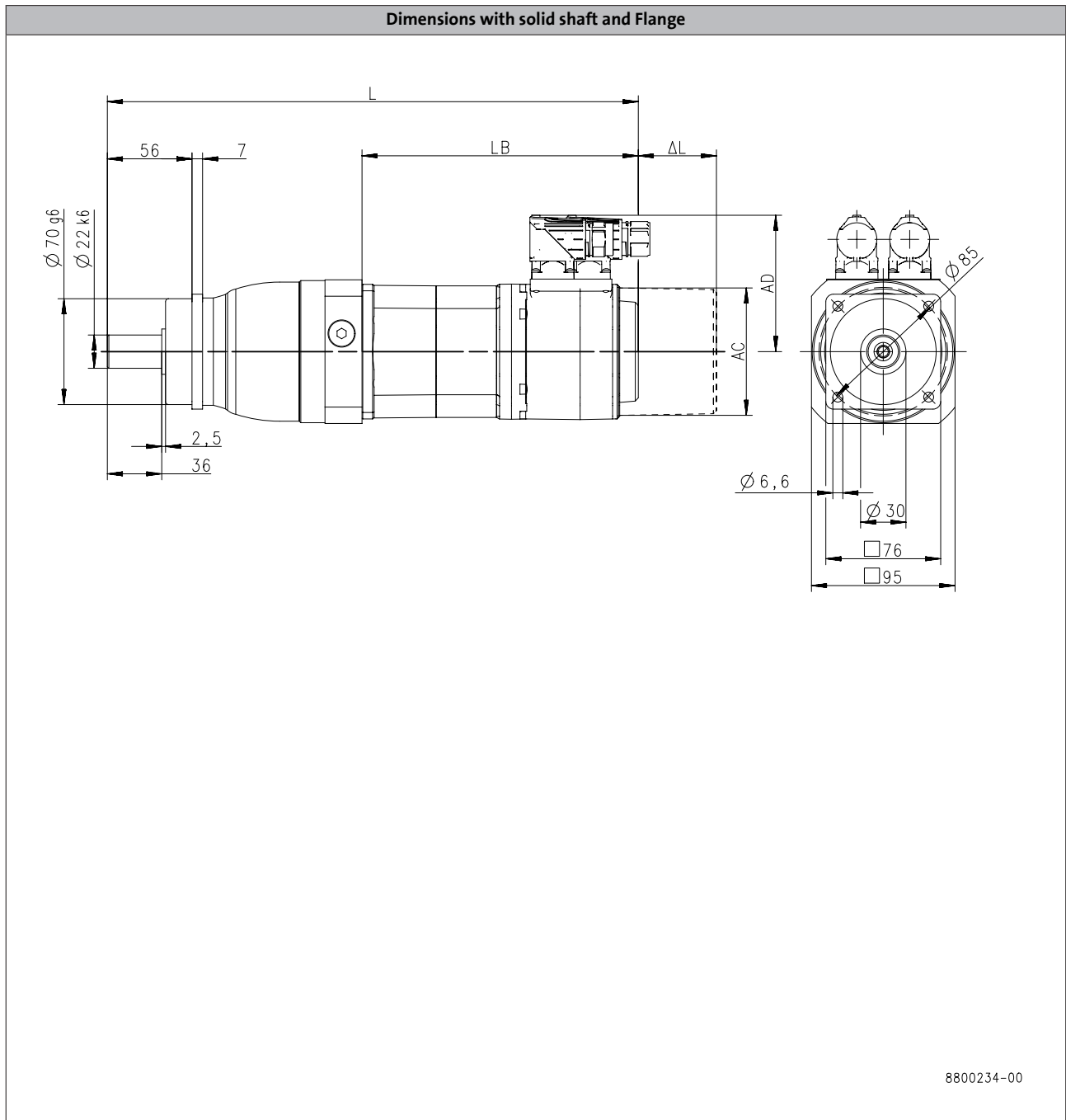

8800234-00

Product			MCS							
			12D17	12D35	12H14	12H34	12L17	12L39	14D14	14D30
Length										
Total length	L	[mm]	430		470		510		468	
Motor length	LB	[mm]	261		301		341		289	
Length of motor options	Δ L	[mm]			63				81.5	
Motor diameter	AC	[mm]			140				167	
Distance motor/connection	AD	[mm]			105				116.5	

MPR planetary geared motors

Technical data



Dimensions, forced ventilated motors

MPR200, 1-stage gearboxes

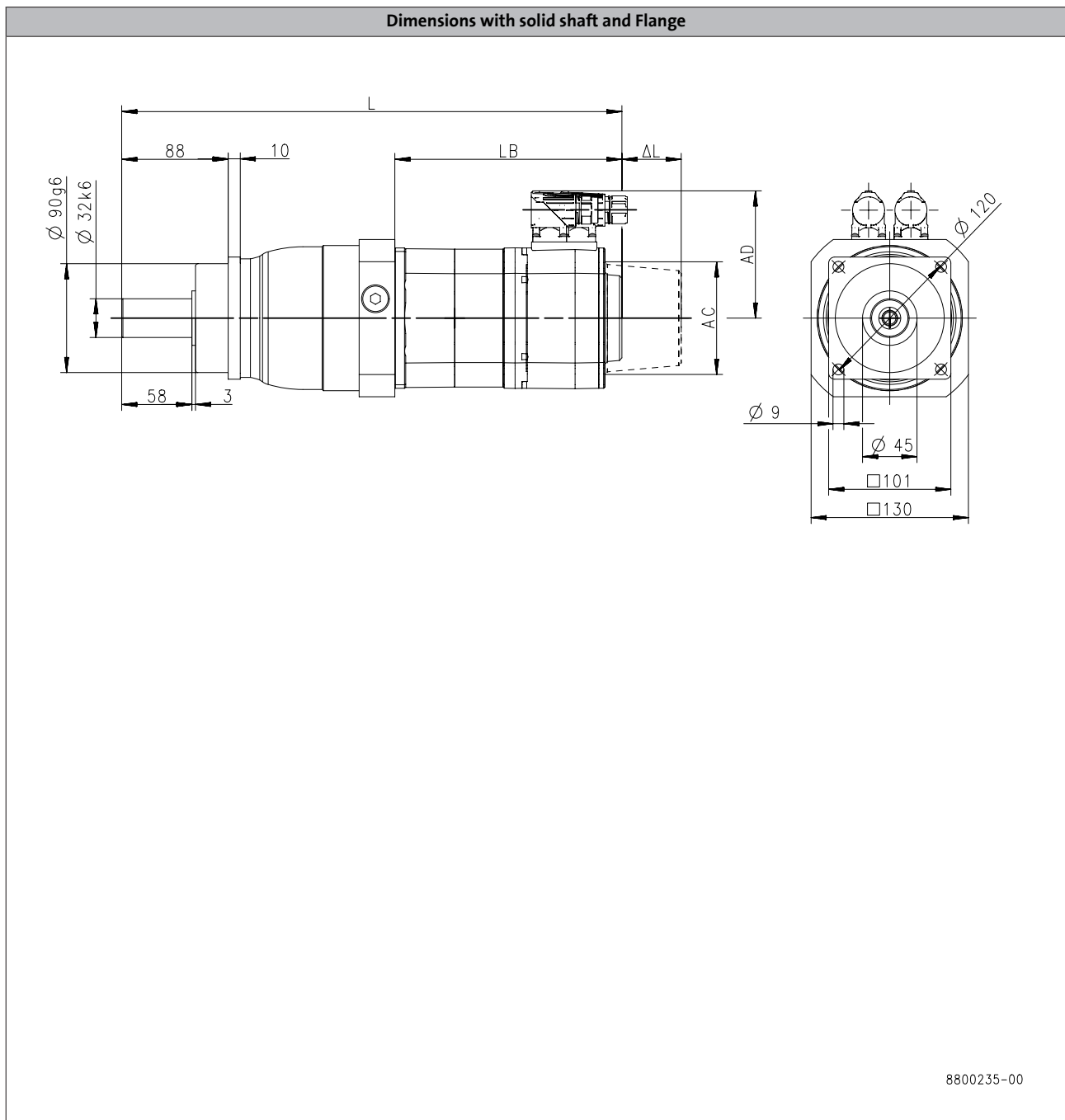

6.2.1

Product			MCS							
			12D17	12D35	12H14	12H34	12L17	12L39	14D14	14D30
Length										
Total length	L	[mm]	487		527		567		515	
Motor length	LB	[mm]	261		301		341		289	
Length of motor options	Δ L	[mm]			63				81.5	
Motor diameter	AC	[mm]			140				167	
Distance motor/connection	AD	[mm]			105				116.5	

MPR planetary geared motors

Technical data



Dimensions, forced ventilated motors

MPR200, 1-stage gearboxes

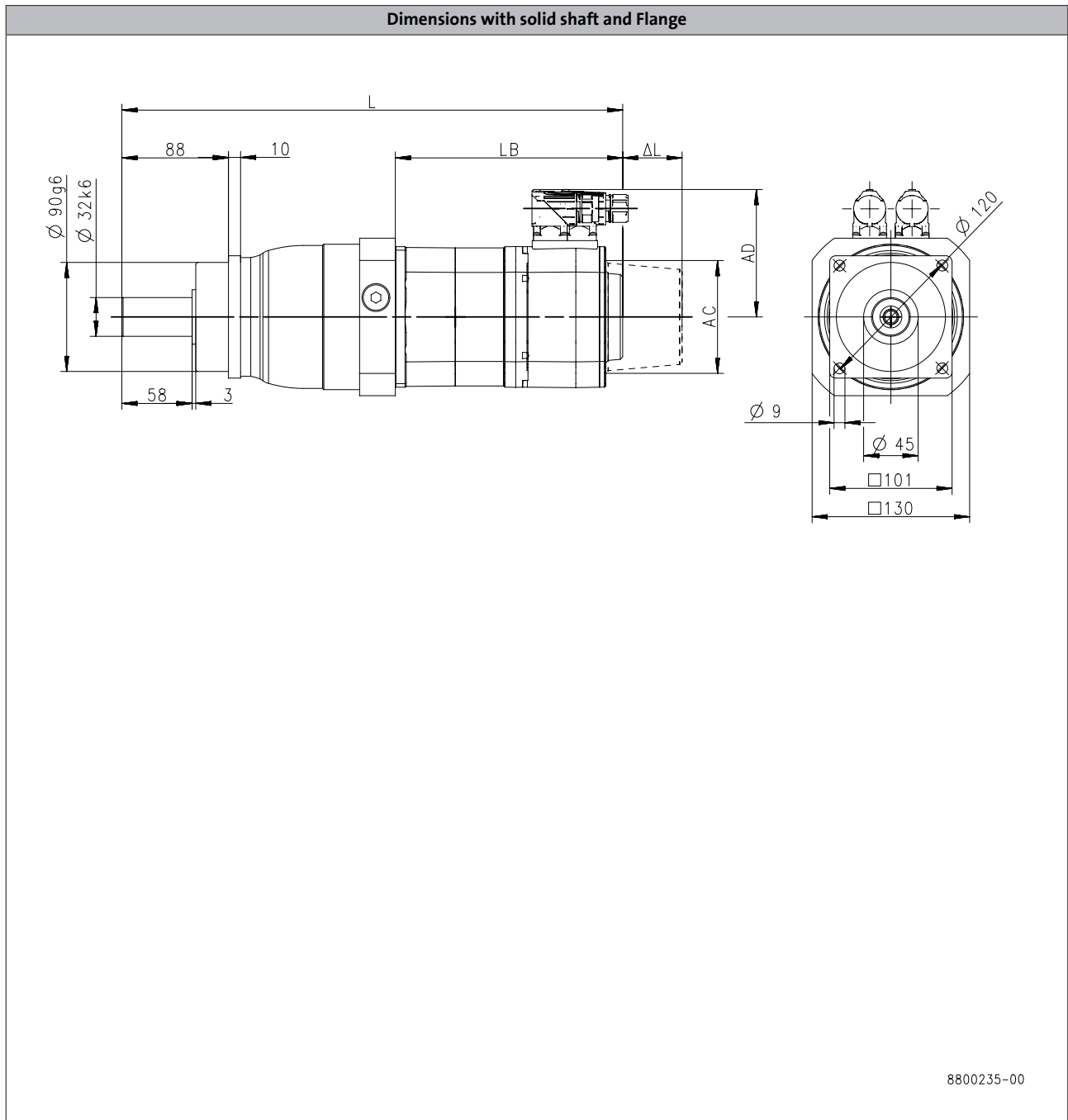

Product			MCS							
			14H12	14H28	14L14	14L30	14P11	14P26	19F12	19F29
Length										
Total length	L	[mm]	555		595		635		553	
Motor length	LB	[mm]	329		369		409		327	
Length of motor options	Δ L	[mm]			81.5				72	
Motor diameter	AC	[mm]			167				212	
Distance motor/connection	AD	[mm]	116.5	146	116.5	146	116.5	146	141.5	171

MPR planetary geared motors

Technical data



Dimensions, forced ventilated motors

MPR200, 2-stage gearboxes

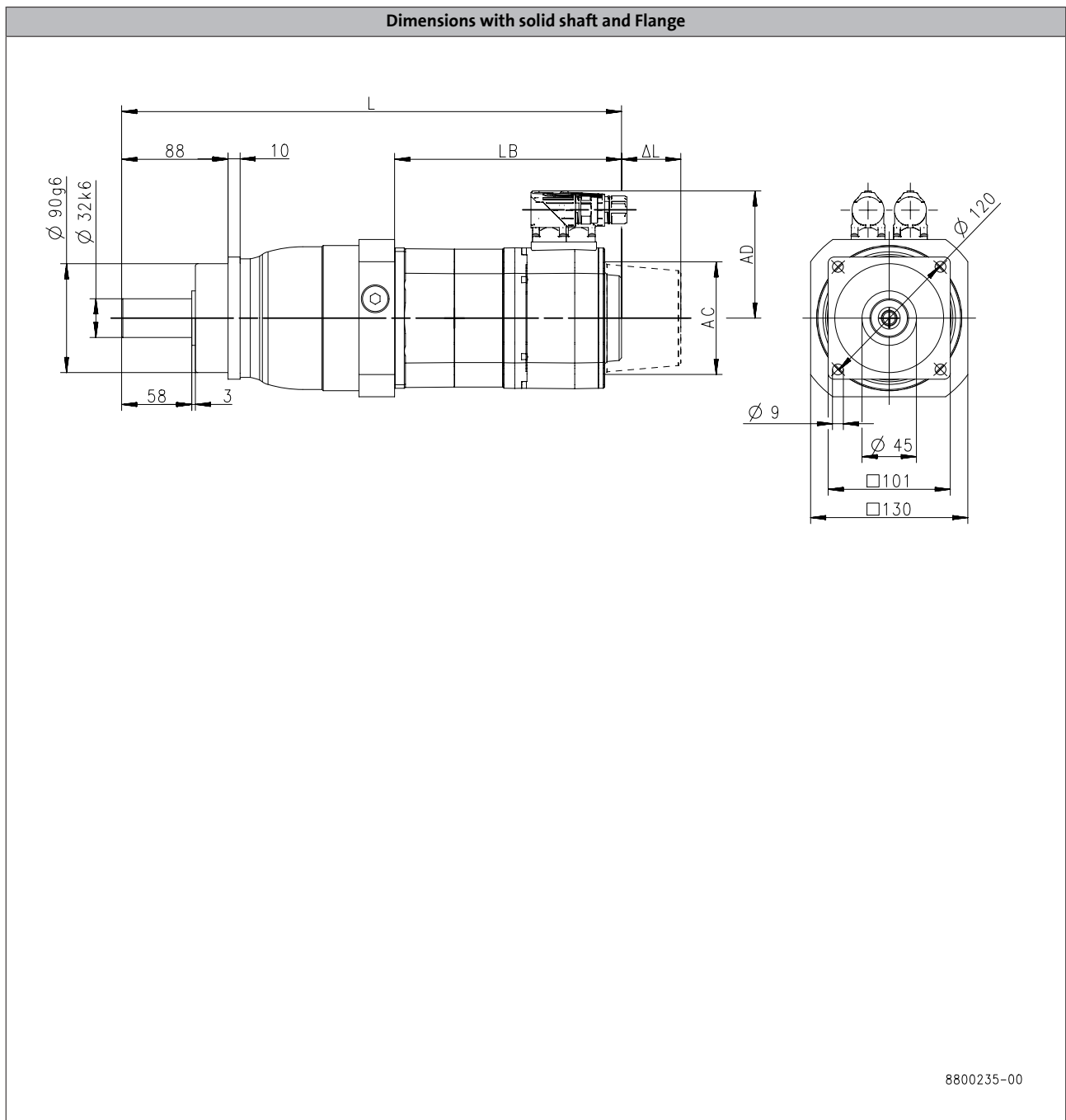

6.2.1

Product	MCS			
	12D17	12D35	12H14	12H34
Length				
Total length	L	[mm]	501	541
Motor length	LB	[mm]	261	301
Length of motor options	Δ L	[mm]	63	
Motor diameter	AC	[mm]	140	
Distance motor/connection	AD	[mm]	105	

MPR planetary geared motors

Technical data



Dimensions, forced ventilated motors

MPR300, 1-stage gearboxes

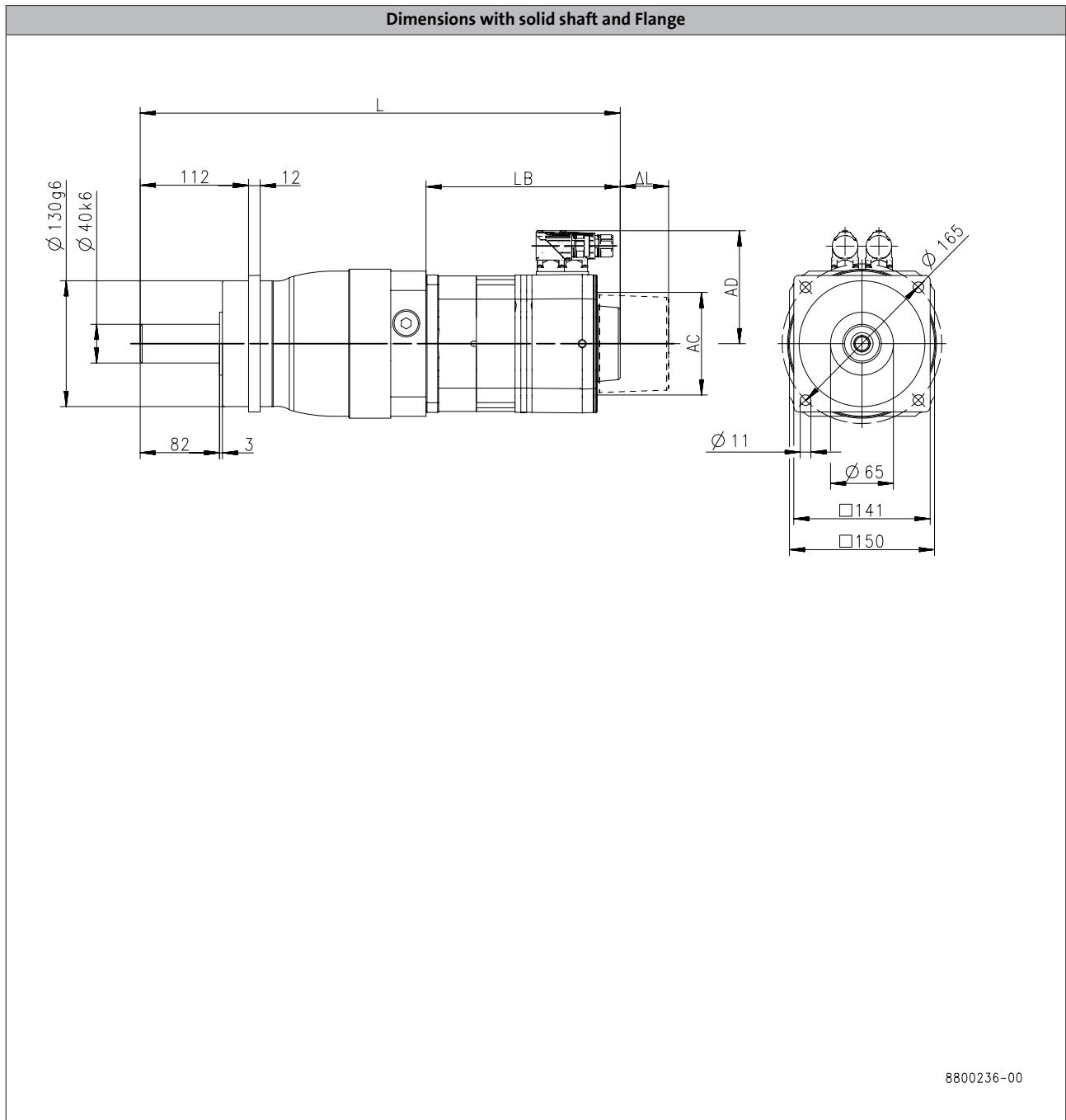

Product			MCS						
			14D14	14D30	14H12	14H28	14L14	14L30	14P11
Length									
Total length	L	[mm]	585		625		665		705
Motor length	LB	[mm]	289		329		369		409
Length of motor options	Δ L	[mm]			81.5				
Motor diameter	AC	[mm]			167				
Distance motor/connection	AD	[mm]		116.5		146	116.5	146	116.5

MPR planetary geared motors

Technical data



Dimensions, forced ventilated motors

MPR300, 1-stage gearboxes

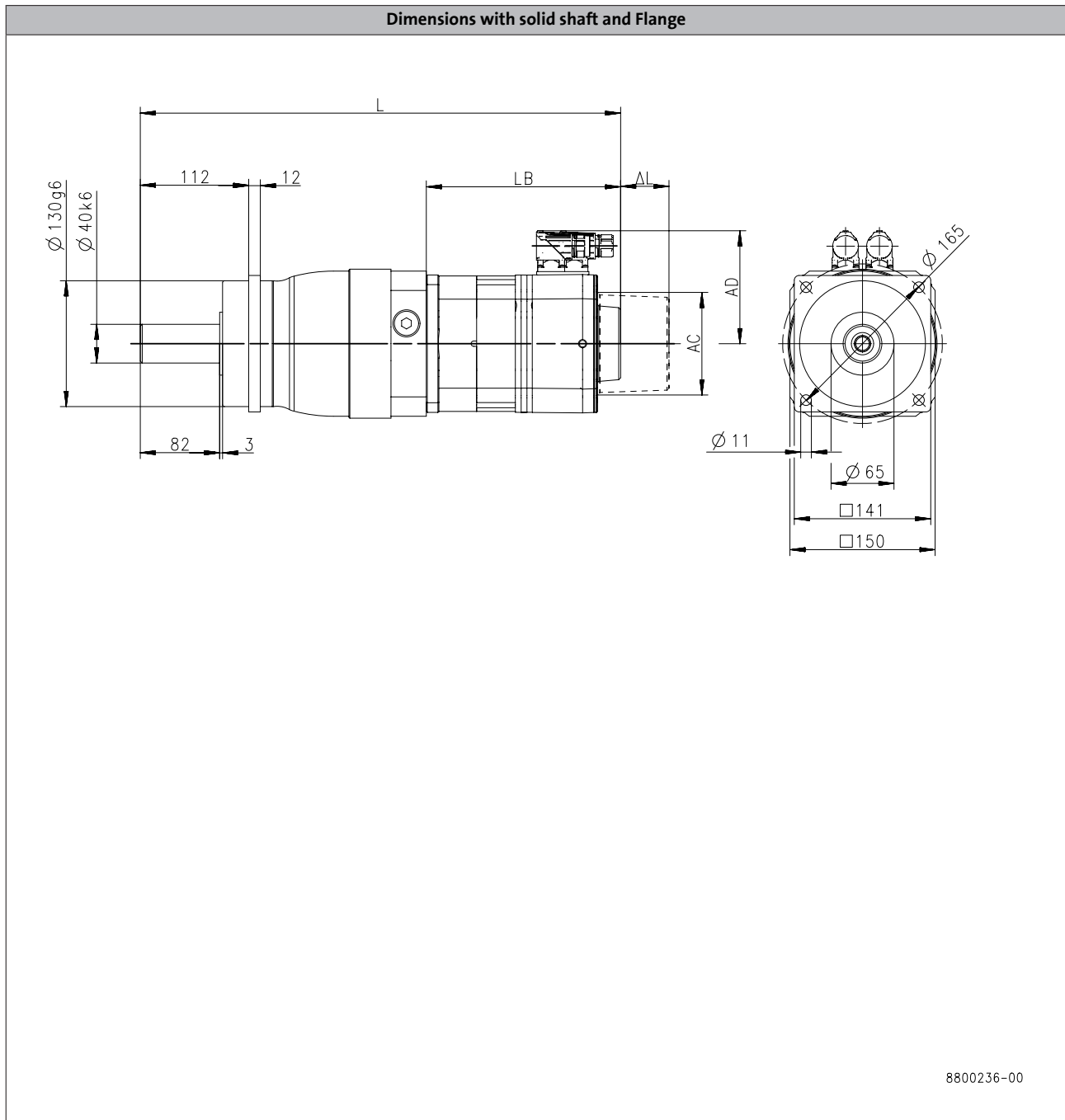

6.2.1

Product			MCS							
			14P26	19F12	19F29	19J12	19J29	19P12	19P29	
Length										
Total length	L	[mm]	705	623		663		723		
Motor length	LB	[mm]	409	327		367		427		
Length of motor options	Δ L	[mm]	81.5	72				82		
Motor diameter	AC	[mm]	167			212				
Distance motor/connection	AD	[mm]	146	141.5				171		

MPR planetary geared motors

Technical data



Dimensions, forced ventilated motors

MPR300, 2-stage gearboxes

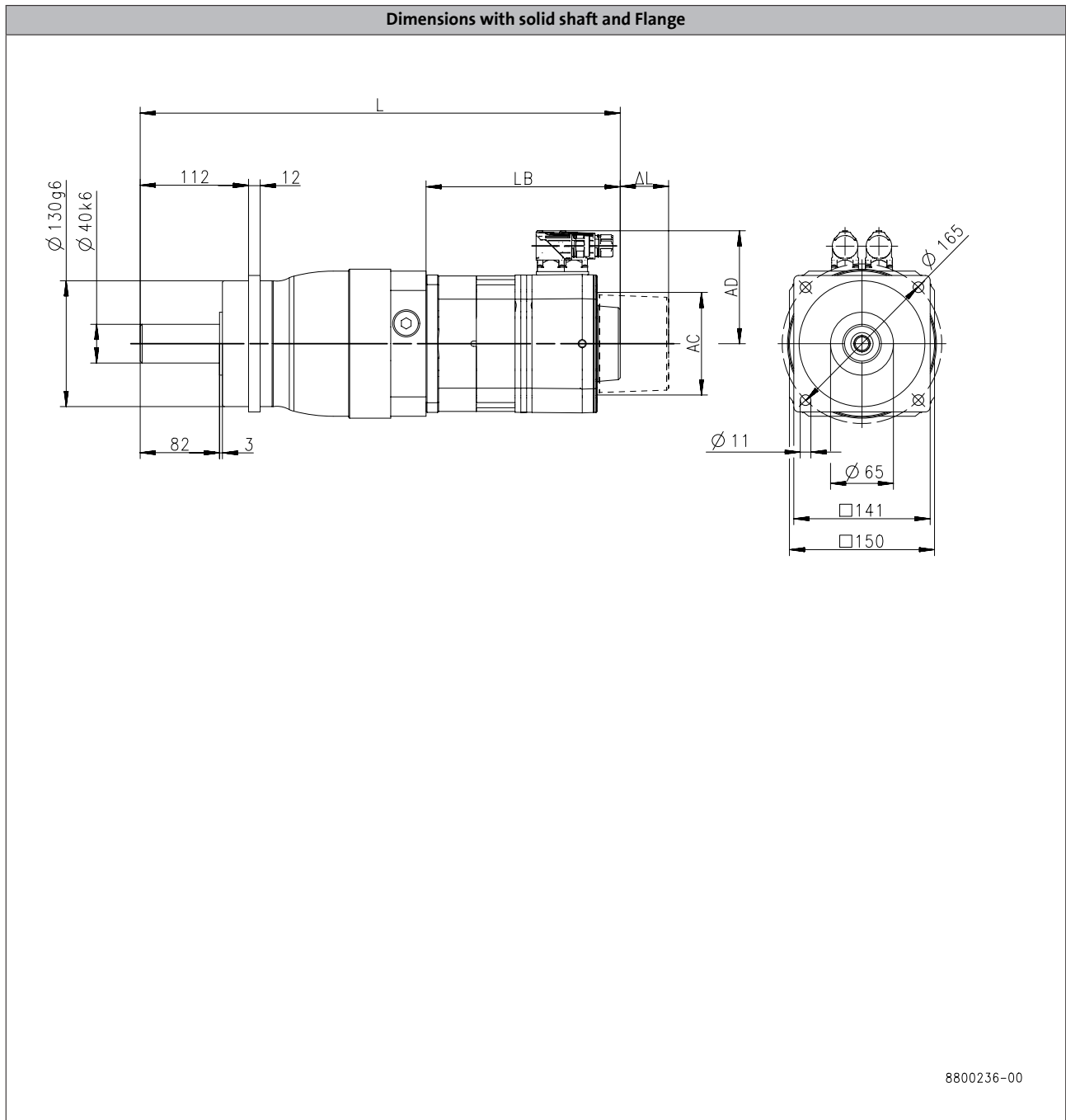

Product			MCS										
			12D17	12D35	12H14	12H34	12L17	12L39	14D14	14D30	14H12	14H28	14L30
Length													
Total length	L	[mm]	575		615		655		603		643		683
Motor length	LB	[mm]	261		301		341		289		329		369
Length of motor options	ΔL	[mm]			63						81.5		
Motor diameter	AC	[mm]			140						167		
Distance motor/connection	AD	[mm]			105				116.5			146	

MPR planetary geared motors

Technical data



Weights, self-ventilated motors

1-stage gearboxes

				MCS								
				06C41 06C60	06F41 06F60	06I41 06I60	09D41 09D60	09F38 09F60	09H41 09H60	09L41 09L51	12D20 12D41	12H15 12H30 12H35
MPR	050	m	[kg]	3.9	4.3	5.0	6.4	7.3	8.2	10	8.5	
	100	m	[kg]				7.4	8.3	9.2	11	9.5	13
	200	m	[kg]								14	17

				MCS								
				12L20 12L41	14D15 14D36	14H15 14H32	14L15 14L32	14P14 14P32	19F14 19F30	19J14 19J30	19P14 19P30	
MPR	100	m	[kg]	16	14							
	200	m	[kg]	20	18	23	27	32	30	37		
	300	m	[kg]		28	33	37	42	40	47	57	

2-stage gearboxes

				MCS								
				06C41 06C60	06F41 06F60	06I41 06I60	09D41	09D60	09F38 09F60	09H41 09H60	09L41 09L51	12D20 12D41
MPR	050	m	[kg]	4.5	4.9	5.6		7.0				
	100	m	[kg]	6.2	6.6	7.3		8.7	9.6	10	12	
	200	m	[kg]					13		14	16	15
	300	m	[kg]									25

				MCS								
				12H15 12H30 12H35	12L20	12L41	14D15 14D36	14H15 14H32	14L15 14L32	14P32	19F30	
MPR	200	m	[kg]	18		21						
	300	m	[kg]	28		32	30	34	39	44	42	

Weights, forced ventilated motors

1-stage gearboxes

				MCS								
				12D17 12D35	12H14 12H34	12L17 12L39	14D14 14D30	14H12 14H28	14L14 14L30	14P11 14P26 19F12 19F29	19J12 19J29	19P12 19P29
MPR	050	m	[kg]	11								
	100	m	[kg]	12	15		18					
	200	m	[kg]	16	19		22	27	31	36		
	300	m	[kg]				32	37	41	46	53	63

2-stage gearboxes

				MCS				
				12D17 12D35	12H14 12H34	12L17 12L39 14D14 14D30	14H12 14H28	14L30
MPR	200	m	[kg]	17	20			
	300	m	[kg]	28	31	34	38	43

MPR planetary geared motors

Technical data



Surface and corrosion protection

For optimum protection of geared motors against ambient conditions, the surface and corrosion protection system (OKS) offers tailor-made solutions.

Various surface coatings combined with other protective measures ensure that the geared motors operate reliably even at high air humidity, in outdoor installations or in the presence of atmospheric impurities. Any colour from the RAL Classic collection can be chosen for the top coat. The geared motors are also available unpainted (no surface and corrosion protection).

Surface and corrosion protection	Applications	Measures
OKS-G (primed)	<ul style="list-style-type: none"> • Dependent on subsequent top coat applied 	<ul style="list-style-type: none"> • 2K PUR priming coat (grey) • Zinc-coated screws • Rust-free breather elements Optional measures <ul style="list-style-type: none"> • Stainless steel nameplate

Structure of surface coating

Surface and corrosion protection	Surface coating
	Structure
Without OKS(uncoated)	Dipping primed gearbox
OKS-G (primed)	Dipping primed gearbox 2K PUR priming coat

MPR planetary geared motors

Technical data



MPR planetary geared motors

Technical data



Gearboxes

MPR planetary-geared motors

6 ... 359 Nm (asynchronous servo motors)

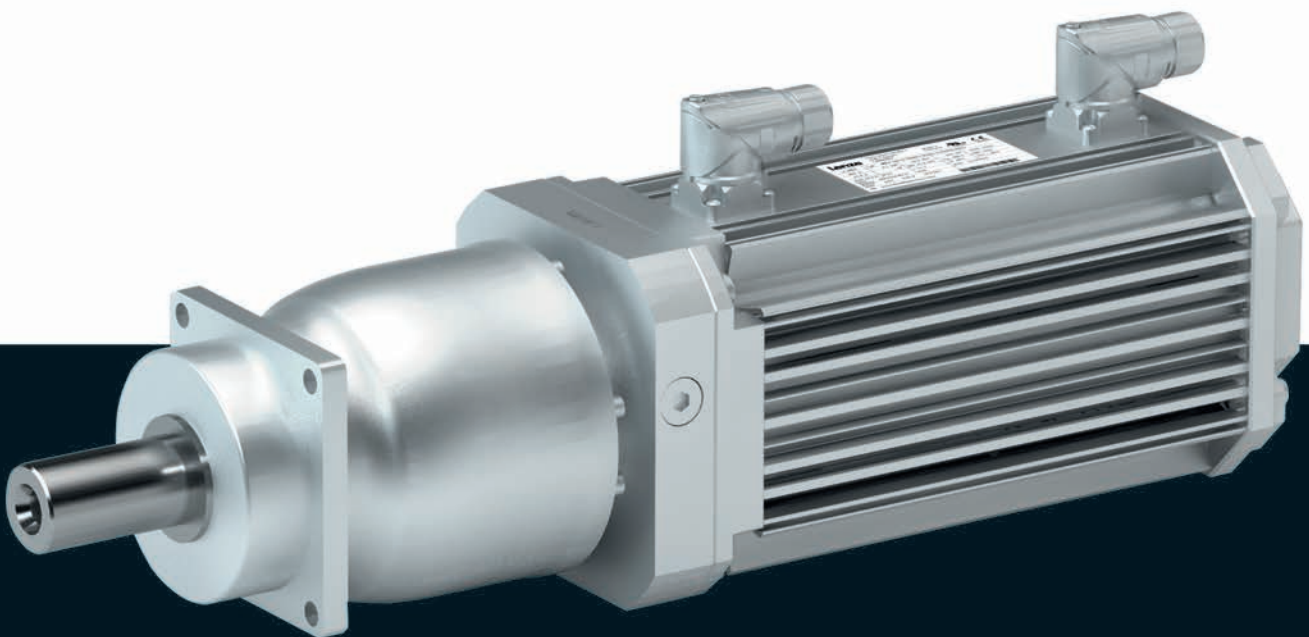

MPR planetary geared motors



Contents

General information	List of abbreviations	6.2.2 - 5
	Product information	6.2.2 - 6
	Equipment	6.2.2 - 7
	The gearbox kit	6.2.2 - 9
	Dimensioning	6.2.2 - 14
Technical data	Selection tables, notes	6.2.2 - 17
	Selection tables	6.2.2 - 18
	Dimensions, notes	6.2.2 - 24
	Dimensions, self-ventilated motors	6.2.2 - 25
	Dimensions, forced ventilated motors	6.2.2 - 32
	Weights, self-ventilated motors	6.2.2 - 37
	Weights, forced ventilated motors	6.2.2 - 38
	Surface and corrosion protection	6.2.2 - 39

MPR planetary geared motors

Contents



MPR planetary geared motors

General information



List of abbreviations

c		Load capacity
i		Ratio
J	[kgcm ²]	Moment of inertia
m	[kg]	Mass
M ₂	[Nm]	Output torque
M _{2, max}	[Nm]	Max. output torque
n _{2, eto}	[r/min]	Transition speed
n _{2, th}	[r/min]	Thermal limit speed

CCC	China Compulsory Certificate
CE	Communauté Européenne
CSA	Canadian Standards Association
cURus	Combined certification marks of UL for the USA and Canada
DIN	Deutsches Institut für Normung e.V.
EMC	Electromagnetic compatibility
EN	European standard
GOST	Certificate for Russian Federation
IEC	International Electrotechnical Commission
IM	International Mounting Code
IP	International Protection Code
NEMA	National Electrical Manufacturers Association
UL	Underwriters Laboratory Listed Product
UR	Underwriters Laboratory Recognized Product
VDE	Verband deutscher Elektrotechniker (Association of German Electrical Engineers)

MPR planetary geared motors



General information

Product information

The combination of Vogel MPR/MPG planetary gearboxes and Lenze servo motors is the optimum solution for dynamic or highly dynamic applications requiring the highest precision. These solutions cater to the requirements such as those encountered on a daily basis in the printing and packaging industry, as well as in the fields of handling and robot technology, filling and materials handling technology and, in many cases, also general engineering.

The MPR/MPG planetary gearboxes feature a higher-than-average torsional stiffness combined with a backlash down to one angular minute. Their combination with MCS synchronous servo motors and MCA asynchronous servo motors creates flexible and particularly energy-efficient solutions which cover virtually every application.

Version

- Robust planetary gearbox with solid shaft (MPR) or flanged shaft (MPG)
- High precision for the application thanks to low backlash (min. ≤ 1 angular minutes)
- Efficient drive solutions with high efficiency (95 ... 97 %)
- Any mounting position which can be changed subsequently as well
- Enclosure IP65 (dust-tight, protection against water jets under any angle)

The product name

Gearbox type	Product range	Rated torque [Nm]	Product
Planetary gearbox	MPR	29	MPR050
		83	MPR100
		200	MPR200
		390	MPR300

MPR planetary geared motors

General information



Equipment

Overview

The equipment includes all the options available as standard and all the built-on accessories of the product.

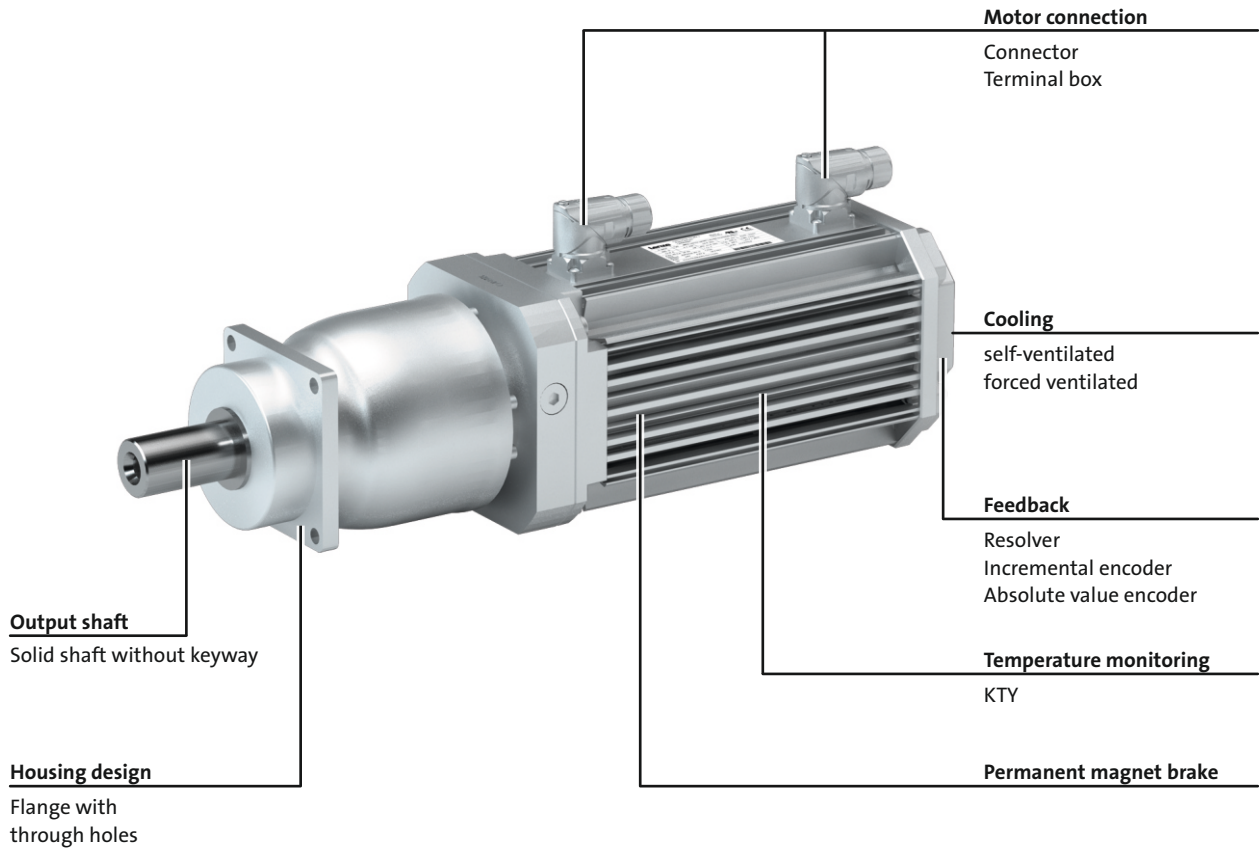

MPR planetary geared motors

General information



MPR planetary geared motors

General information



The gearbox kit

Geared motor

Product	MPR050	MPR100	MPR200	MPR300
Motor type	Asynchronous servo motor			
Servo motor				
2.0 Nm	MCA10			
4.0 - 6.3 Nm		MCA13		
5.4 - 12 Nm			MCA14	
9.5 - 21 Nm			MCA17	
12 - 36 Nm				MCA19
17 - 61 Nm				
Technical data				
Output torque	See selection table			
Output speed	See selection table			
Ratio	See selection table			
Load capacity	See selection table			
Moment of inertia	See selection table			
Mounting position				
Standard	Any			
Colour				
	primed (RAL 9005M, matt jet black)			
Surface and corrosion protection				
	Without OKS(uncoated) OKS-G (primed)			

MPR planetary geared motors

General information



The gearbox kit

Motor details

Product	MCA					
	10I40	13I34 13I41	14L16 14L20 14L35 14L41	17N17 17N23 17N35 17N41	19S17 19S23 19S35 19S42	21X17 21X25 21X35 21X42
Connection type	Plug connectors Terminal box					
Permanent magnet holding brake						
Rated torque [Nm]	3.3	12	15	24	46	88
Brake voltage [V]	DC 24 AC 230					
Feedback	With absolute value encoder With incremental encoder With resolver					
Cooling	Self-ventilated	Self-ventilated Forced-ventilated				
Temperature monitoring	KTY83-110 thermal detector					
Approval	cURus GOST_R UkrSepro					
Degree of protection	IP54 IP65					

- Further information and installation feasibilities can be found in the Motors chapter.









MPR planetary geared motors

General information



The gearbox kit

Motor details

Connection type		
 Plug connectors	 Terminal box	
Cooling: self-ventilated		
 With resolver	 With permanent magnet brake	 With feedback With feedback and permanent magnet brake
Cooling: forced ventilated		
 With resolver	 With permanent magnet brake	 With feedback With feedback and permanent magnet brake

6.2.2

MPR planetary geared motors

General information



The gearbox kit

Gearbox details

Product	MPR050	MPR100	MPR200	MPR300
Driven shaft				
Solid shaft without keyway [mm]	16x28	22x36	32x58	40x82
Design	Standard			
Gasket	NBR			
Bearing	Standard			
Housing				
Housing version	Without foot with centering			
Output flange				
Flange square [mm]	62	76	101	141
Lubricant				
Type	Mobil SHC 629			
Breather element	Without			
Backlash				
Backlash	Standard Reduced			

- Further information and installation feasibilities can be found in the Gearboxes chapter.

MPR planetary geared motors

General information



The gearbox kit

Gearbox details

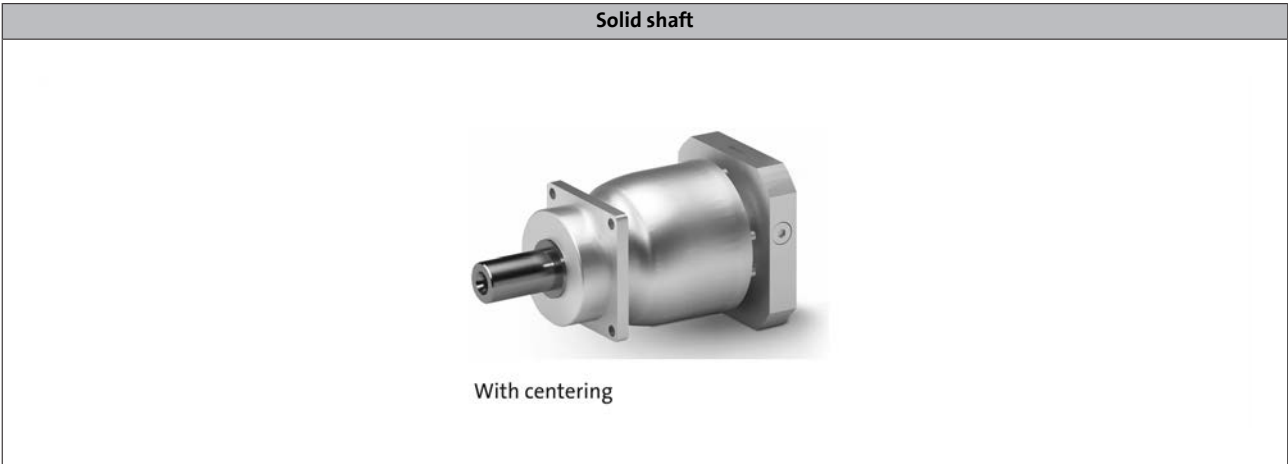

MPR planetary geared motors



General information

Dimensioning

General information about the data provided in this catalogue

The powers, torques and speeds specified in this catalogue are rounded values and are valid under the following conditions:

- Operating time/day = 8 h (100% OT)
- Duty class I for up to 10 switching operations/h
- Mounting positions and designs in this catalogue
- Standard lubricant
- $T_{amb} = 30\text{ °C}$ for gearboxes,
 $T_{amb} = 40\text{ °C}$ for motors (in accordance with EN 60034)
- Site altitude $< = 1000\text{ m amsl}$
- The selection tables provide the permissible mechanical powers and torques. For notes on the thermal power limit, see chapter drive dimensioning.
- The rated power specified for motors and geared motors applies to operating mode S1 (in accordance with EN 60034).

Under different operating conditions, the values obtained may vary from those listed here.

In the case of extreme operating conditions, please consult your Lenze sales office.

MPR planetary geared motors



General information

Dimensioning

Load capacity and application factor

Load capacity c of gearbox

Rated value for the load capacity of Lenze geared motors.

- c is the ratio of the permissible rated torque of the gearbox to the rated torque supplied by the drive component (e.g. the built-in Lenze motor).
- The value of c must always be greater than the value of the application factor k calculated for the application.

Application factor k (according to DIN 3990)

Takes into account the influence of temporally variable loads which are actually present during the anticipated operating time of gearboxes and geared motors.

k is determined by:

- the type of load
- the load intensity
- temporal influences

Duty class	Load type
I	Smooth operation, small or light jolts
II	Uneven operation, average jolts
III	Uneven operation, severe jolts and/or alternating load

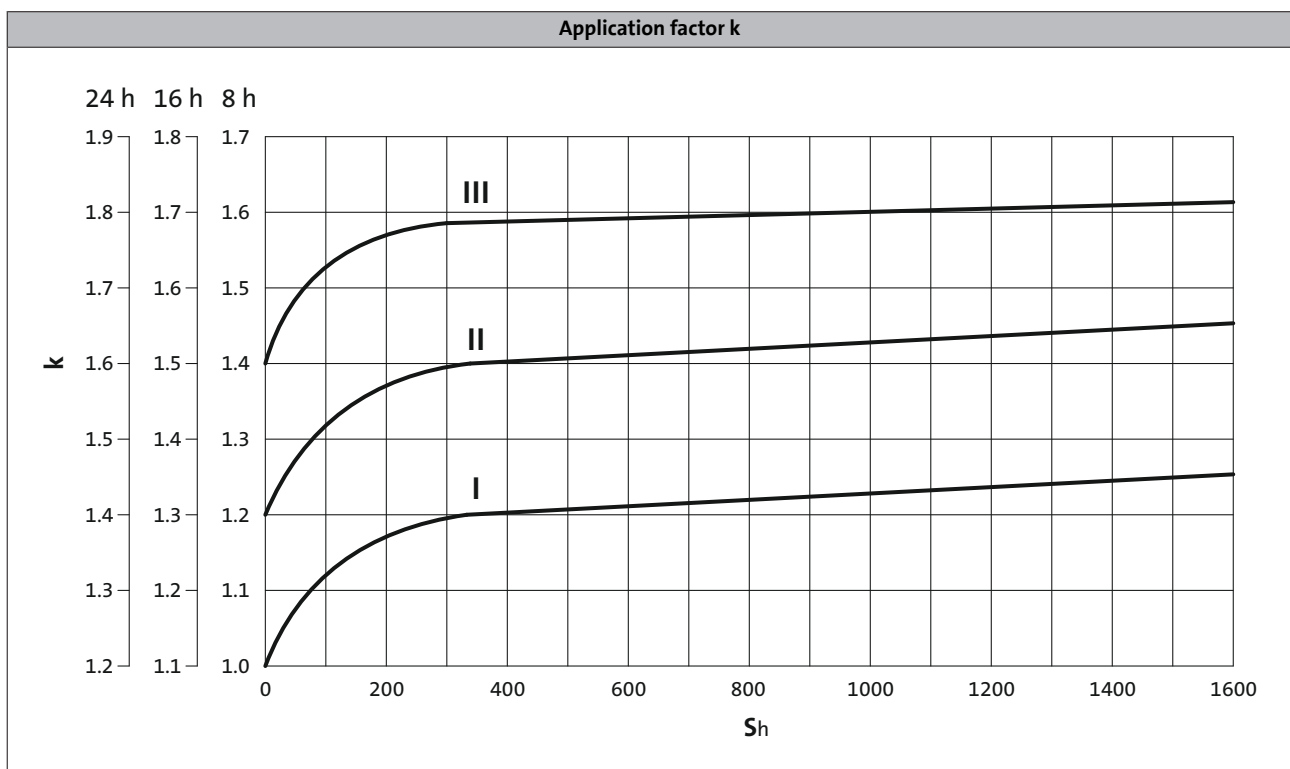

► S_h = switchings/h

MPR planetary geared motors



General information

Dimensioning

Weights

The values given in the tables consider the following gearbox/motor combination:

- Gearbox with solid shaft including lubricant amount
- Motor with feedback

For versions deviating from this, additional weights have to be considered.

The respective values can be found for:

- Geared motors with feedback
 - > Chapter: Geared motors/Technical data
- Motor options: Brake
 - > Chapter: Motors/Accessories

Moments of inertia

The given moments of inertia of the gearbox refer to the drive shaft. The influence of the ratio (i^2) has been considered in the data.

When the total moment of inertia of the geared motor is calculated, the values of the geared motors and the brake have to be added.

The respective values can be found for:

- Geared motors with feedback
 - > Chapter: Geared motors/Technical data/Selection tables
- Motor options: Brake
 - > Chapter: Motors/Accessories

MPR planetary geared motors



Technical data

Selection tables, notes

Notes on the selection tables

The selection tables show the available combinations of gearbox type, number of stages, ratio and motor. They are used only to provide basic orientation.

The following legend indicates the structure of the selection tables.

Number of the gear stage of the gearbox



2-stage gearboxes

Inverter operation						i	Product		Cooling	
M _{2, max} [Nm]	n _{2, th} [r/min]	M ₂ [Nm]	n _{2, eto} [r/min]	c	J [kgcm ²]		MPR	MCS		
20	333	6	333	3.6	0.300	12.000	050	06C60	Selbst	40
20	333	7	333	3.0	0.300	12.000	050	06C41	Selbst	40
20	333	10	333	1.9	0.400	12.000	050	06F60	Selbst	40
20	333	14	333	1.5	0.400	12.000	050	06F41	Selbst	40

For operating mode S1
Torque M₂ and
thermal output speed n_{2, th}

For operating mode S2, S3 und S6
Max. permissible acceleration torque of geared
motor M_{2, max} and
output speed n_{2, eto}

Moment of inertia of
geared motor

Ratio i

Product
Gearbox

Product
Motor

Type of
motor cooling

Page number
for dimensions

Load capacity of the gearbox
c is the ratio between the permissible rated torque of the gearbox and the rated torque of the three-phase AC motor (converted to the driven shaft). c must be always higher than the service factor k determined for the application k.

$$c = \frac{M_{2, zul}}{M_{1N} \cdot i \cdot \eta_{Getr}} > k$$

MPR planetary geared motors



Technical data

Selection tables

1-stage gearboxes

Inverter operation						i	Product		Cooling	
M _{2, max} [Nm]	n _{2, th} [r/min]	M ₂ [Nm]	n _{2, eto} [r/min]	c	J [kgcm ²]		MPR	MCA		
19	395	19	395	1.0	2.600	10.000	050	10I40	natural	25
20	1100	6	1100	3.5	2.800	3.000	050	10I40	natural	25
29	825	8	825	3.9	2.700	4.000	050	10I40	natural	25
29	660	9	660	3.1	2.600	5.000	050	10I40	natural	25
29	529	13	529	2.2	2.600	7.000	050	10I40	natural	25
56	933	12	933	4.8	9.500	3.000	100	13I41	natural	26
56	933	18	933	3.1	9.500	3.000	100	13I34	forced	32
58	310	19	310	3.1	2.900	10.000	100	10I40	natural	26
58	310	39	310	1.5	8.900	10.000	100	13I41	natural	26
83	700	16	700	5.3	9.200	4.000	100	13I41	natural	26
83	700	24	700	3.5	9.200	4.000	100	13I34	forced	32
83	560	19	560	4.3	9.100	5.000	100	13I41	natural	26
83	560	30	560	2.8	9.100	5.000	100	13I34	forced	32
83	400	27	400	3.0	9.000	7.000	100	13I41	natural	26
83	400	42	400	2.0	9.000	7.000	100	13I34	forced	32
135	833	28	833	4.9	41.000	3.000	200	17N41	natural	28
135	833	31	833	4.3	24.000	3.000	200	14L35	forced	33
135	833	55	833	2.5	41.000	3.000	200	17N35	forced	33
135	767	31	767	4.3	41.000	3.000	200	17N23	natural	28
135	560	63	560	2.1	41.000	3.000	200	17N17	forced	33
135	545	36	545	3.8	24.000	3.000	200	14L16	forced	33
135	280	39	280	3.5	11.000	10.000	200	13I41	natural	28
135	280	52	280	2.6	22.000	10.000	200	14L41	natural	28
135	280	60	280	2.3	11.000	10.000	200	13I34	forced	33
135	280	92	280	1.5	39.000	10.000	200	17N41	natural	28
135	280	105	280	1.3	22.000	10.000	200	14L35	forced	33
135	230	105	230	1.3	39.000	10.000	200	17N23	natural	28
135	200	65	200	2.1	22.000	10.000	200	14L20	natural	28
135	164	119	164	1.1	22.000	10.000	200	14L16	forced	33
190	400	36	400	5.2	22.000	7.000	200	14L41	natural	28
190	400	42	400	4.5	11.000	7.000	200	13I34	forced	33
190	400	65	400	2.9	39.000	7.000	200	17N41	natural	28
190	400	73	400	2.6	22.000	7.000	200	14L35	forced	33
190	400	129	400	1.5	39.000	7.000	200	17N35	forced	33
190	329	73	329	2.6	39.000	7.000	200	17N23	natural	28
190	286	45	286	4.2	22.000	7.000	200	14L20	natural	28
190	240	147	240	1.3	39.000	7.000	200	17N17	forced	33
190	234	83	234	2.3	22.000	7.000	200	14L16	forced	33
195	500	46	500	4.2	39.000	5.000	200	17N41	natural	28
195	500	52	500	3.7	23.000	5.000	200	14L35	forced	33

6.2.2

MPR planetary geared motors



Technical data

Selection tables

1-stage gearboxes

Inverter operation						i	Product		Cooling	
M _{2, max} [Nm]	n _{2, th} [r/min]	M ₂ [Nm]	n _{2, eto} [r/min]	c	J [kgcm ²]		MPR	MCA		
195	500	92	500	2.1	39.000	5.000	200	17N35	forced	33
195	460	52	460	3.7	39.000	5.000	200	17N23	natural	28
195	336	105	336	1.9	39.000	5.000	200	17N17	forced	33
195	327	59	327	3.3	23.000	5.000	200	14L16	forced	33
200	625	37	625	5.4	40.000	4.000	200	17N41	natural	28
200	625	42	625	4.8	23.000	4.000	200	14L35	forced	33
200	625	73	625	2.7	40.000	4.000	200	17N35	forced	33
200	575	42	575	4.8	40.000	4.000	200	17N23	natural	28
200	420	84	420	2.4	40.000	4.000	200	17N17	forced	33
200	409	48	409	4.2	23.000	4.000	200	14L16	forced	33
245	260	52	260	4.7	26.000	10.000	300	14L41	natural	30
245	260	92	260	2.6	42.000	10.000	300	17N41	natural	30
245	260	105	260	2.3	26.000	10.000	300	14L35	forced	35
245	260	116	260	2.1	80.000	10.000	300	19S42	natural	30
245	260	184	260	1.3	42.000	10.000	300	17N35	forced	35
245	234	158	234	1.6	80.000	10.000	300	19S23	natural	30
245	230	105	230	2.3	42.000	10.000	300	17N23	natural	30
245	200	65	200	3.8	26.000	10.000	300	14L20	natural	30
245	168	210	168	1.2	42.000	10.000	300	17N17	forced	35
245	164	119	164	2.1	26.000	10.000	300	14L16	forced	35
290	700	55	700	5.3	50.000	3.000	300	17N35	forced	35
290	700	105	700	2.8	87.000	3.000	300	19S35	forced	35
290	567	105	567	2.8	87.000	3.000	300	19S17	forced	35
290	560	63	560	4.6	50.000	3.000	300	17N17	forced	35
380	329	65	329	5.9	43.000	7.000	300	17N41	natural	30
380	329	73	329	5.2	43.000	7.000	300	17N23	natural	30
380	329	73	329	5.2	26.000	7.000	300	14L35	forced	35
380	329	81	329	4.7	81.000	7.000	300	19S42	natural	30
380	329	111	329	3.4	81.000	7.000	300	19S23	natural	30
380	329	129	329	3.0	43.000	7.000	300	17N35	forced	35
380	329	244	329	1.6	81.000	7.000	300	19S35	forced	35
380	243	244	243	1.6	81.000	7.000	300	19S17	forced	35
380	240	147	240	2.6	43.000	7.000	300	17N17	forced	35
380	234	83	234	4.6	26.000	7.000	300	14L16	forced	35
388	525	73	525	5.3	46.000	4.000	300	17N35	forced	35
388	420	84	420	4.7	46.000	4.000	300	17N17	forced	35
390	525	139	525	2.8	83.000	4.000	300	19S35	forced	35
390	425	139	425	2.8	83.000	4.000	300	19S17	forced	35
390	420	79	420	4.9	82.000	5.000	300	19S23	natural	30
390	420	92	420	4.3	44.000	5.000	300	17N35	forced	35

6.2.2

MPR planetary geared motors

Technical data



Selection tables

1-stage gearboxes

Inverter operation						i	Product		Cooling	
$M_{2, \max}$ [Nm]	$n_{2, th}$ [r/min]	M_2 [Nm]	$n_{2, eto}$ [r/min]	c	J [kgcm ²]		MPR	MCA		
390	420	174	420	2.2	82.000	5.000	300	19S35	forced	35
390	340	174	340	2.2	82.000	5.000	300	19S17	forced	35
390	336	105	336	3.7	44.000	5.000	300	17N17	forced	35

MPR planetary geared motors



Technical data

Selection tables

2-stage gearboxes

Inverter operation						i	Product		Cooling	
M _{2, max} [Nm]	n _{2, th} [r/min]	M ₂ [Nm]	n _{2, eto} [r/min]	c	J [kgcm ²]		MPR	MCA		
56	258	22	258	2.5	2.700	12.000	100	10I40	natural	27
76	88	73	88	1.0	2.600	40.000	100	10I40	natural	27
83	219	29	219	2.8	2.700	16.000	100	10I40	natural	27
83	175	37	175	2.3	2.600	20.000	100	10I40	natural	27
83	140	46	140	1.8	2.600	25.000	100	10I40	natural	27
83	125	51	125	1.6	2.600	28.000	100	10I40	natural	27
83	100	64	100	1.3	2.600	35.000	100	10I40	natural	27
135	233	46	233	3.0	9.300	12.000	200	13I41	natural	29
135	233	70	233	1.9	9.300	12.000	200	13I34	forced	34
190	155	37	155	5.3	3.000	20.000	200	10I40	natural	29
190	56	129	56	1.5	2.900	70.000	200	10I40	natural	29
195	155	76	155	2.6	9.100	20.000	200	13I41	natural	29
195	155	117	155	1.7	9.100	20.000	200	13I34	forced	34
195	124	46	124	4.3	3.000	25.000	200	10I40	natural	29
195	124	95	124	2.0	9.000	25.000	200	13I41	natural	29
195	124	146	124	1.3	9.000	25.000	200	13I34	forced	34
195	89	64	89	3.0	2.900	35.000	200	10I40	natural	29
195	89	133	89	1.5	8.900	35.000	200	13I41	natural	29
195	70	92	70	2.1	2.900	50.000	200	10I40	natural	29
195	70	190	70	1.0	8.900	50.000	200	13I41	natural	29
200	194	61	194	3.3	9.200	16.000	200	13I41	natural	29
200	194	94	194	2.1	9.200	16.000	200	13I34	forced	34
200	111	51	111	3.9	2.900	28.000	200	10I40	natural	29
200	111	107	111	1.9	9.000	28.000	200	13I41	natural	29
200	111	164	111	1.2	9.000	28.000	200	13I34	forced	34
200	78	73	78	2.7	2.900	40.000	200	10I40	natural	29
200	78	152	78	1.3	8.900	40.000	200	13I41	natural	29
290	217	61	217	4.8	22.000	12.000	300	14L41	natural	31
290	217	70	217	4.1	11.000	12.000	300	13I34	forced	36
290	217	109	217	2.7	39.000	12.000	300	17N41	natural	31
290	217	123	217	2.4	22.000	12.000	300	14L35	forced	36
290	217	216	217	1.3	39.000	12.000	300	17N35	forced	36
290	192	123	192	2.4	39.000	12.000	300	17N23	natural	31
290	167	76	167	3.8	22.000	12.000	300	14L20	natural	31
290	140	246	140	1.2	39.000	12.000	300	17N17	forced	36
290	136	140	136	2.1	22.000	12.000	300	14L16	forced	36
380	46	267	46	1.4	10.000	70.000	300	13I41	natural	31
380	46	356	46	1.1	22.000	70.000	300	14L41	natural	31
390	181	81	181	4.8	22.000	16.000	300	14L41	natural	31
390	181	94	181	4.2	11.000	16.000	300	13I34	forced	36

6.2.2

MPR planetary geared motors



Technical data

Selection tables

2-stage gearboxes

Inverter operation						i	Product		Cooling	
M _{2, max} [Nm]	n _{2, th} [r/min]	M ₂ [Nm]	n _{2, eto} [r/min]	c	J [kgcm ²]		MPR	MCA		
390	181	145	181	2.7	39.000	16.000	300	17N41	natural	31
390	181	164	181	2.4	22.000	16.000	300	14L35	forced	36
390	181	288	181	1.4	39.000	16.000	300	17N35	forced	36
390	145	76	145	5.1	11.000	20.000	300	13I41	natural	31
390	145	102	145	3.8	22.000	20.000	300	14L41	natural	31
390	145	117	145	3.3	11.000	20.000	300	13I34	forced	36
390	145	181	145	2.1	39.000	20.000	300	17N41	natural	31
390	145	205	145	1.9	22.000	20.000	300	14L35	forced	36
390	145	360	145	1.1	39.000	20.000	300	17N35	forced	36
390	144	164	144	2.4	39.000	16.000	300	17N23	natural	31
390	125	102	125	3.8	22.000	16.000	300	14L20	natural	31
390	116	95	116	4.1	11.000	25.000	300	13I41	natural	31
390	116	127	116	3.1	22.000	25.000	300	14L41	natural	31
390	116	146	116	2.7	11.000	25.000	300	13I34	forced	36
390	116	226	116	1.7	39.000	25.000	300	17N41	natural	31
390	116	256	116	1.5	22.000	25.000	300	14L35	forced	36
390	115	205	115	1.9	39.000	20.000	300	17N23	natural	31
390	105	328	105	1.2	39.000	16.000	300	17N17	forced	36
390	104	107	104	3.7	10.000	28.000	300	13I41	natural	31
390	104	142	104	2.7	22.000	28.000	300	14L41	natural	31
390	104	164	104	2.4	10.000	28.000	300	13I34	forced	36
390	104	253	104	1.5	39.000	28.000	300	17N41	natural	31
390	104	287	104	1.4	22.000	28.000	300	14L35	forced	36
390	102	186	102	2.1	22.000	16.000	300	14L16	forced	36
390	100	127	100	3.1	22.000	20.000	300	14L20	natural	31
390	92	256	92	1.5	39.000	25.000	300	17N23	natural	31
390	83	133	83	2.9	10.000	35.000	300	13I41	natural	31
390	83	178	83	2.2	22.000	35.000	300	14L41	natural	31
390	83	205	83	1.9	10.000	35.000	300	13I34	forced	36
390	83	317	83	1.2	39.000	35.000	300	17N41	natural	31
390	83	358	83	1.1	22.000	35.000	300	14L35	forced	36
390	82	233	82	1.7	22.000	20.000	300	14L16	forced	36
390	82	287	82	1.4	39.000	28.000	300	17N23	natural	31
390	80	159	80	2.5	22.000	25.000	300	14L20	natural	31
390	73	152	73	2.6	10.000	40.000	300	13I41	natural	31
390	73	204	73	1.9	22.000	40.000	300	14L41	natural	31
390	73	234	73	1.7	10.000	40.000	300	13I34	forced	36
390	73	362	73	1.1	39.000	40.000	300	17N41	natural	31
390	71	178	71	2.2	22.000	28.000	300	14L20	natural	31
390	66	359	66	1.1	39.000	35.000	300	17N23	natural	31

6.2.2

MPR planetary geared motors

Technical data



Selection tables

2-stage gearboxes

Inverter operation						i	Product		Cooling	
M _{2, max} [Nm]	n _{2, th} [r/min]	M ₂ [Nm]	n _{2, eto} [r/min]	c	J [kgcm ²]		MPR	MCA		
390	65	291	65	1.3	22.000	25.000	300	14L16	forced	36
390	64	190	64	2.0	10.000	50.000	300	13I41	natural	31
390	64	293	64	1.3	10.000	50.000	300	13I34	forced	36
390	58	254	58	1.5	22.000	50.000	300	14L41	natural	31
390	58	326	58	1.2	22.000	28.000	300	14L16	forced	36
390	57	222	57	1.8	22.000	35.000	300	14L20	natural	31
390	50	254	50	1.5	22.000	40.000	300	14L20	natural	31
390	40	318	40	1.2	22.000	50.000	300	14L20	natural	31

MPR planetary geared motors

Technical data



Dimensions, notes

Notes on the dimensions

The following legend shows the layout of the dimension sheets.

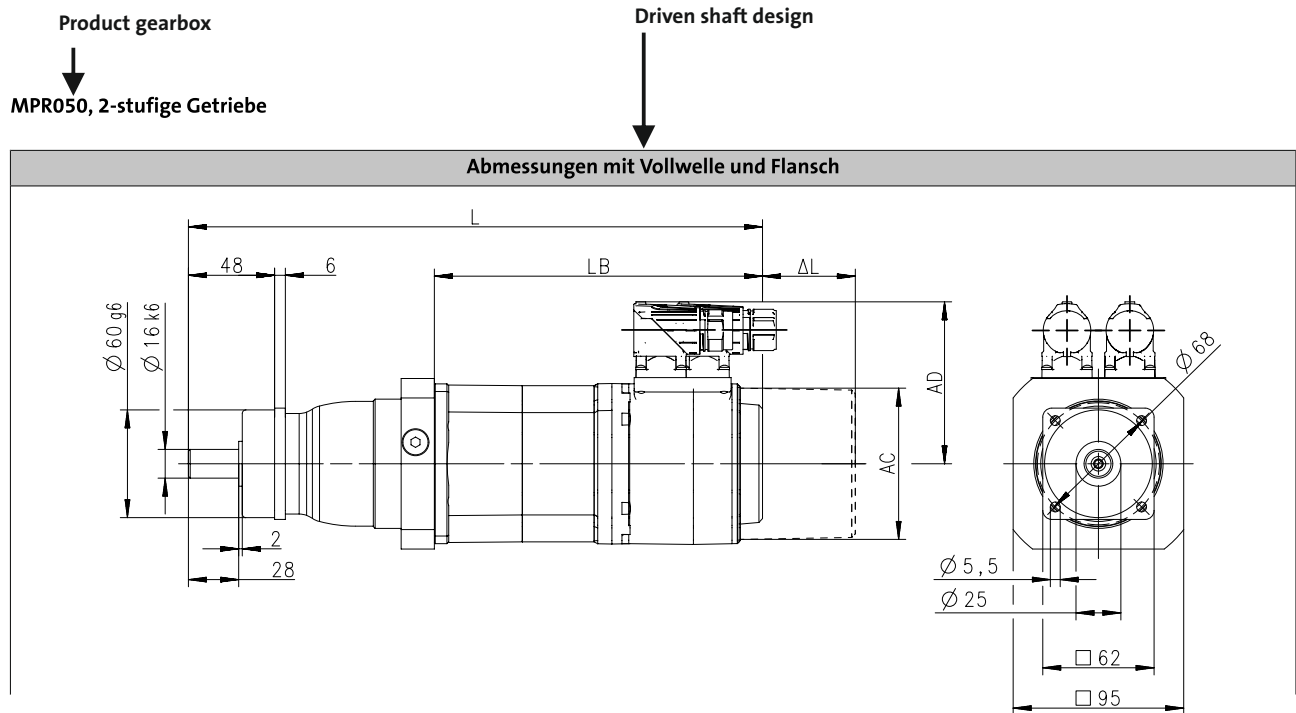

Product Motor

Produkt			MCS						
			06C41	06C60	06F41	06F60	06I41	06I60	09D60
Länge									
Gesamtlänge	L	[mm]	298			328		358	349
Länge Motor	LB	[mm]	182			162		192	183
Länge Motoranbauten	ΔL	[mm]			100				71
Motordurchmesser	AC	[mm]				86			89
Abstand Motor/Anschluss	AD	[mm]				77			89.7

Distance of motor centre to the end of connector

Total length of the drive without built-on accessories

Motor diameter

Motor length without built-on accessories

Additional length of the built-on accessories (longest version)

6.2.2

MPR planetary geared motors

Technical data



Dimensions, self-ventilated motors

MPR0501-stage gearboxes

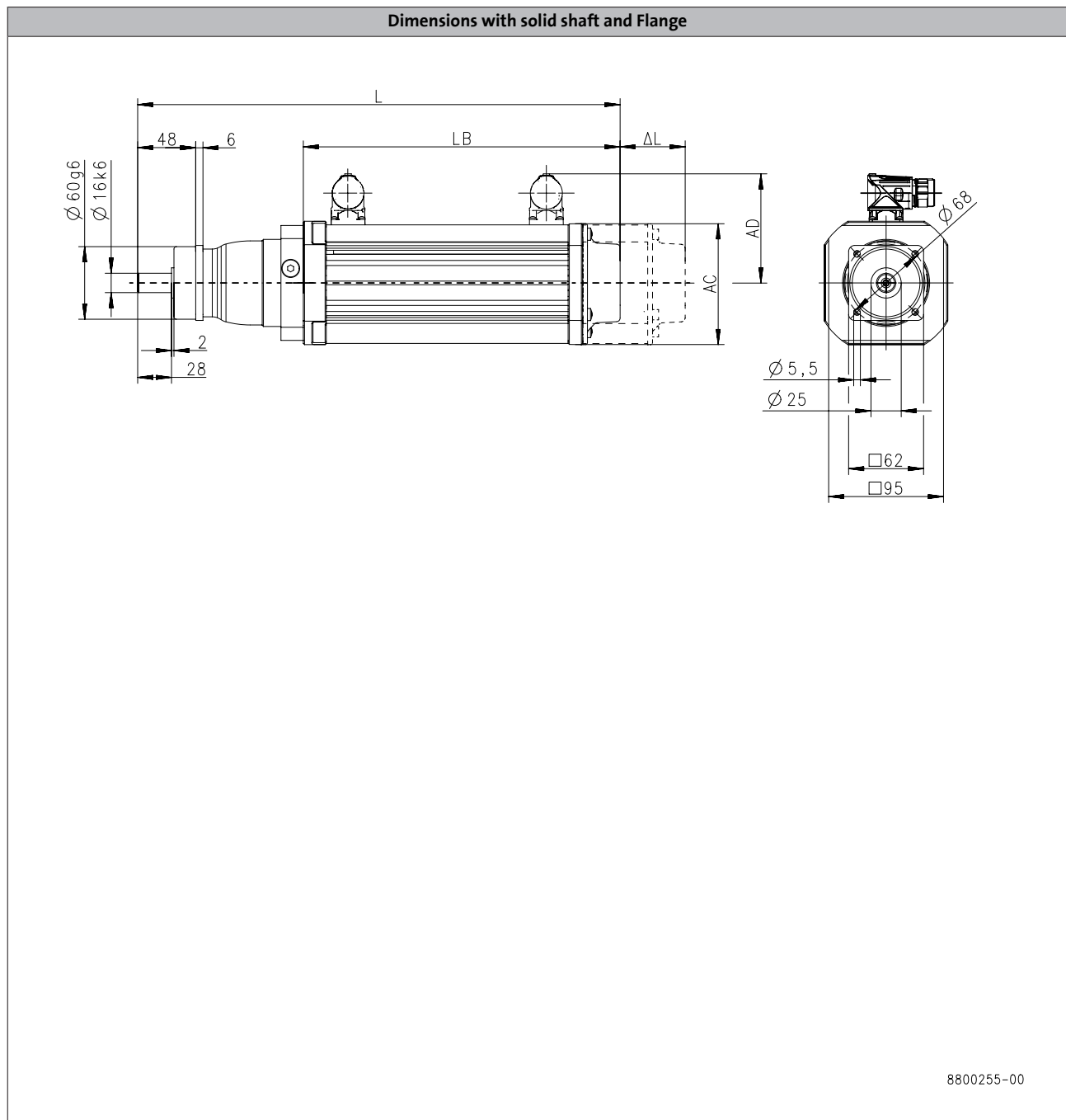

6.2.2

Product			MCA
			10I40
Length			
Total length	L	[mm]	399
Motor length	LB	[mm]	262
Length of motor options	ΔL	[mm]	78.5
Motor diameter	AC	[mm]	102
Distance motor/connection	AD	[mm]	90

MPR planetary geared motors

Technical data



Dimensions, self-ventilated motors

MPR100, 1-stage gearboxes

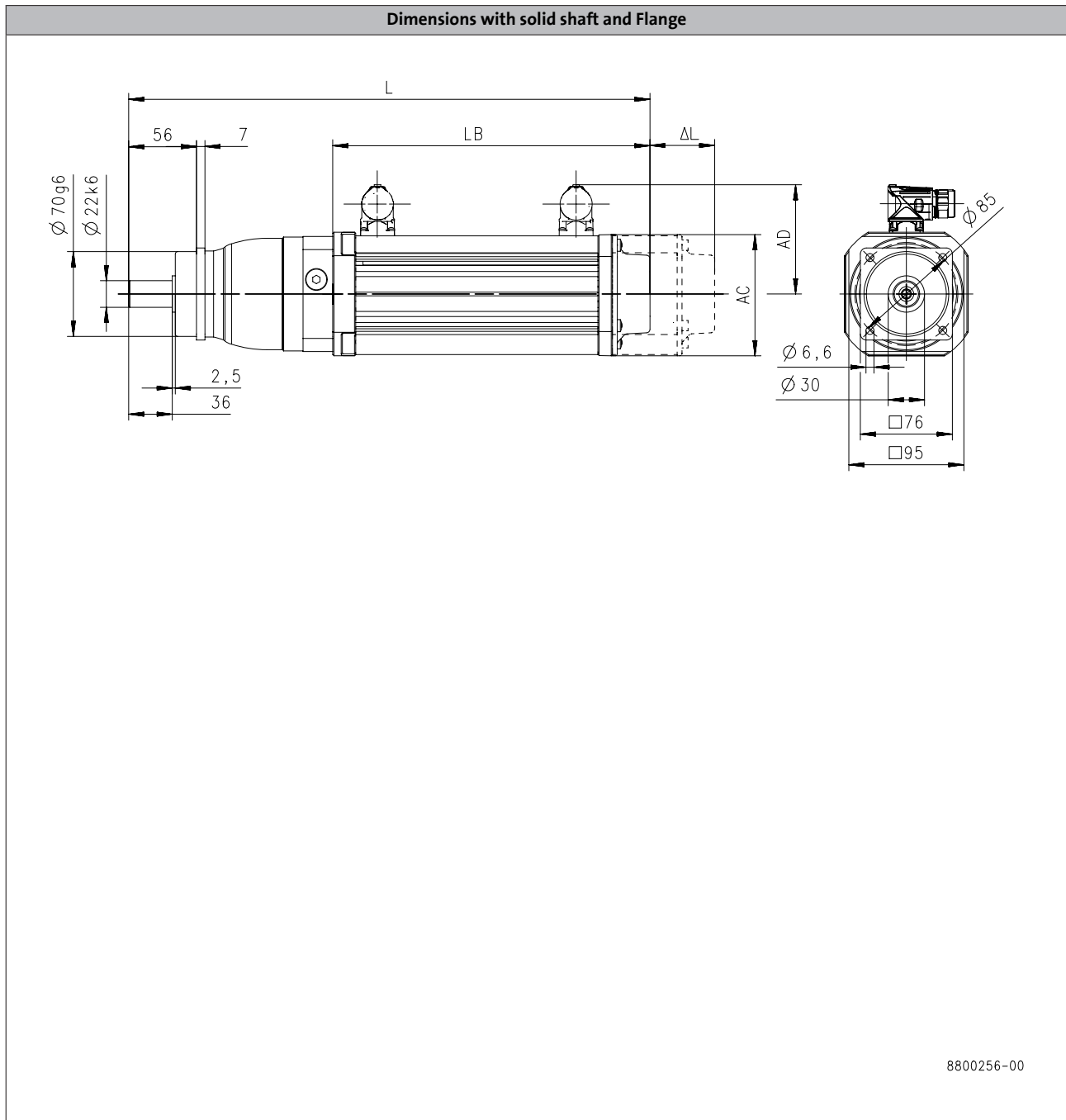

Product			MCA	
			10I40	13I41
Length				
Total length	L	[mm]	431	439
Motor length	LB	[mm]	262	270.5
Length of motor options	Δ L	[mm]	78.5	89
Motor diameter	AC	[mm]	102	130
Distance motor/connection	AD	[mm]	90	102

MPR planetary geared motors

Technical data



Dimensions, self-ventilated motors

MPR100: 2-stage gearboxes

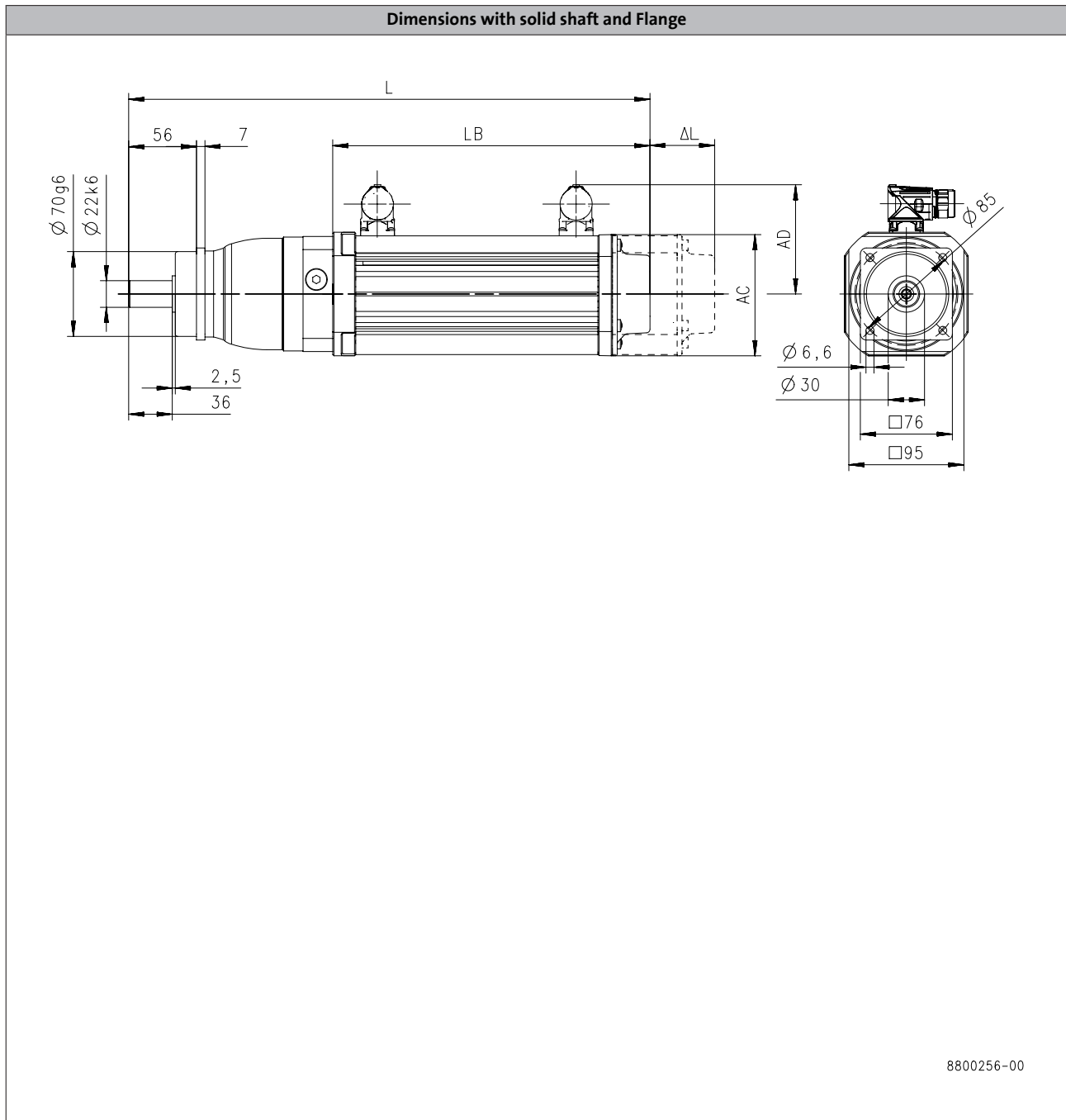

6.2.2

Product			MCA
			10I40
Length			
Total length	L	[mm]	451
Motor length	LB	[mm]	262
Length of motor options	Δ L	[mm]	78.5
Motor diameter	AC	[mm]	102
Distance motor/connection	AD	[mm]	90

MPR planetary geared motors

Technical data



Dimensions, self-ventilated motors

MPR200, 1-stage gearboxes

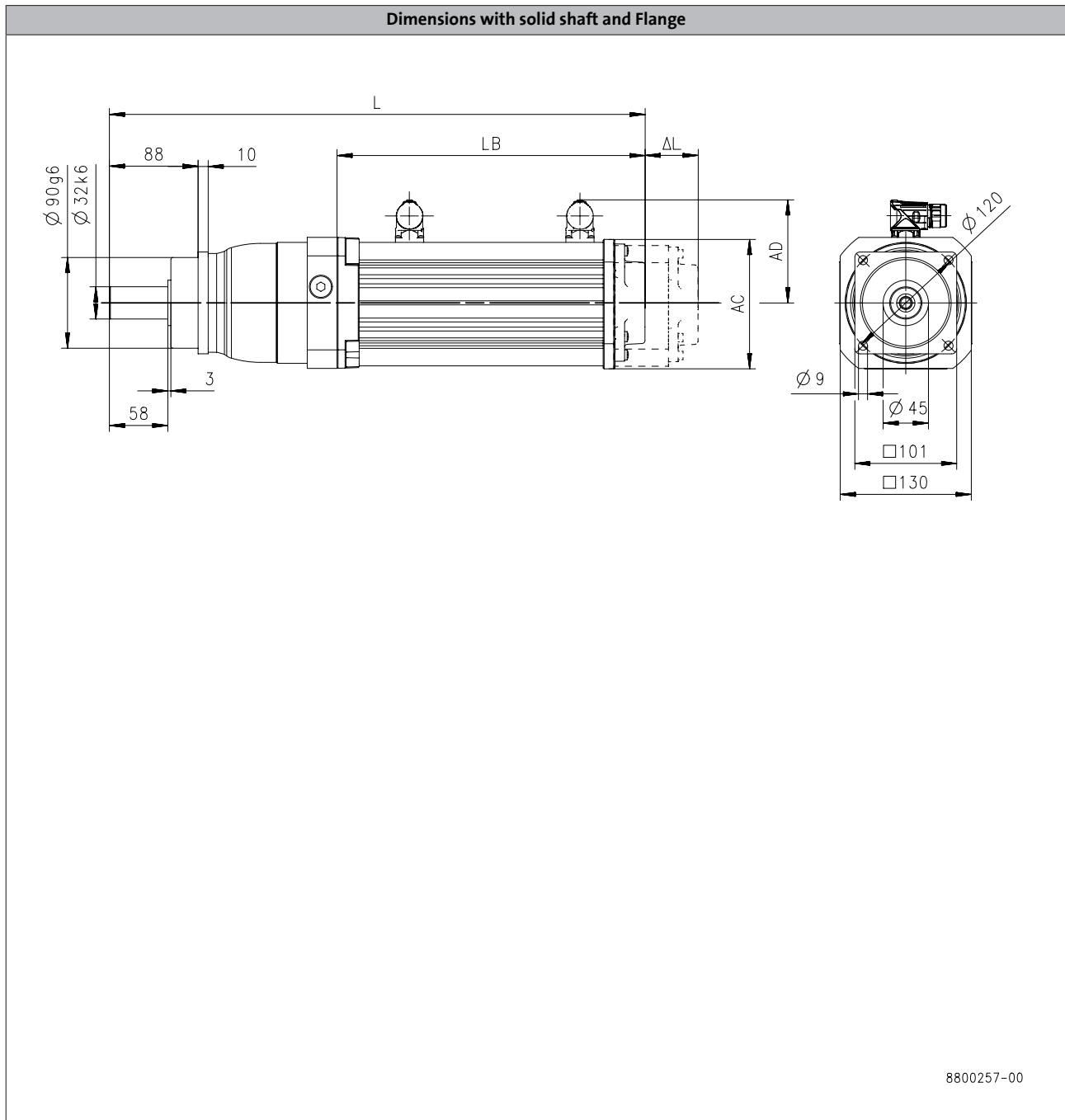

Product			MCA				
			13I41	14L20	14L41	17N23	17N41
Length							
Total length	L	[mm]	496		527		565
Motor length	LB	[mm]	270.5		301.5		339.5
Length of motor options	Δ L	[mm]	89		88.5		89.2
Motor diameter	AC	[mm]	130		142		165
Distance motor/connection	AD	[mm]	102		109		117.5

6.2.2

MPR planetary geared motors

Technical data



Dimensions, self-ventilated motors

MPR200, 2-stage gearboxes

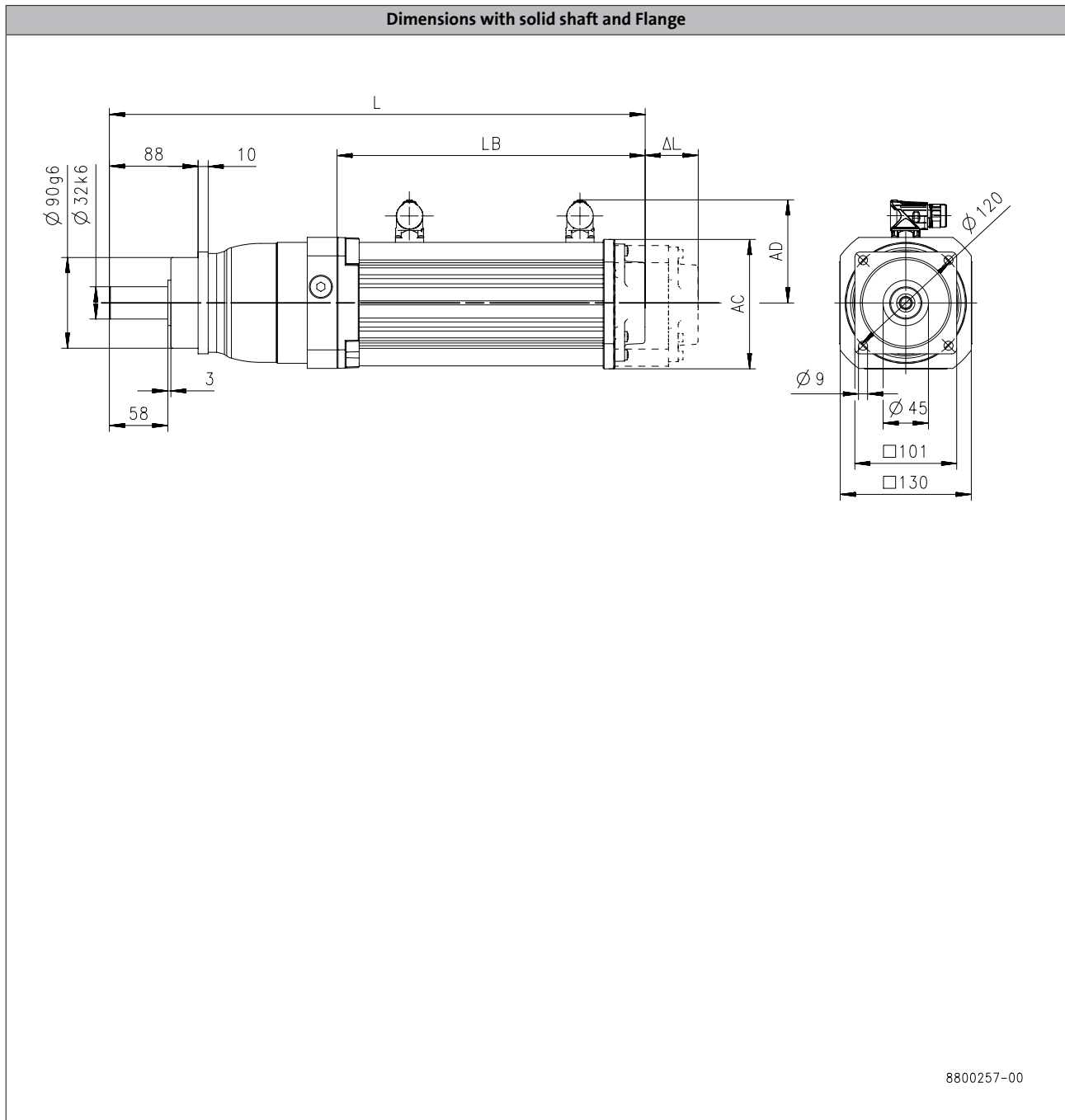

6.2.2

Product			MCA	
			10I40	13I41
Length				
Total length	L	[mm]	502	510
Motor length	LB	[mm]	262	270.5
Length of motor options	Δ L	[mm]	78.5	89
Motor diameter	AC	[mm]	102	130
Distance motor/connection	AD	[mm]	90	102

MPR planetary geared motors

Technical data



Dimensions, self-ventilated motors

MPR300, 1-stage gearboxes

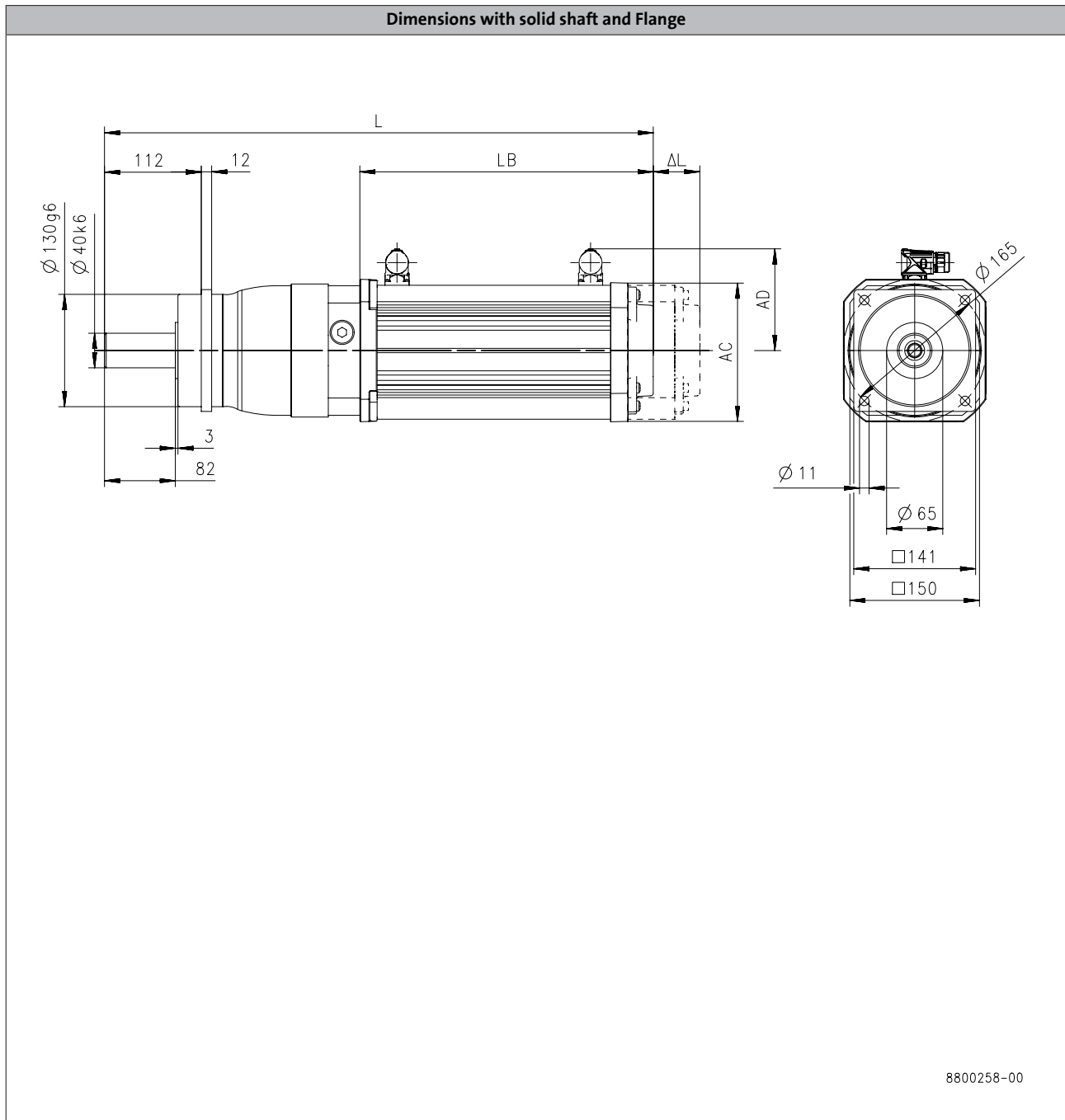

8800258-00

Product			MCA					
			14L20	14L41	17N23	17N41	19S23	19S42
Length								
Total length	L	[mm]	597		635			697
Motor length	LB	[mm]	301.5		339.5			401
Length of motor options	Δ L	[mm]	88.5		89.2			88.2
Motor diameter	AC	[mm]	142		165			192
Distance motor/connection	AD	[mm]	109		117.5			151

MPR planetary geared motors

Technical data



Dimensions, self-ventilated motors

MPR300, 2-stage gearboxes

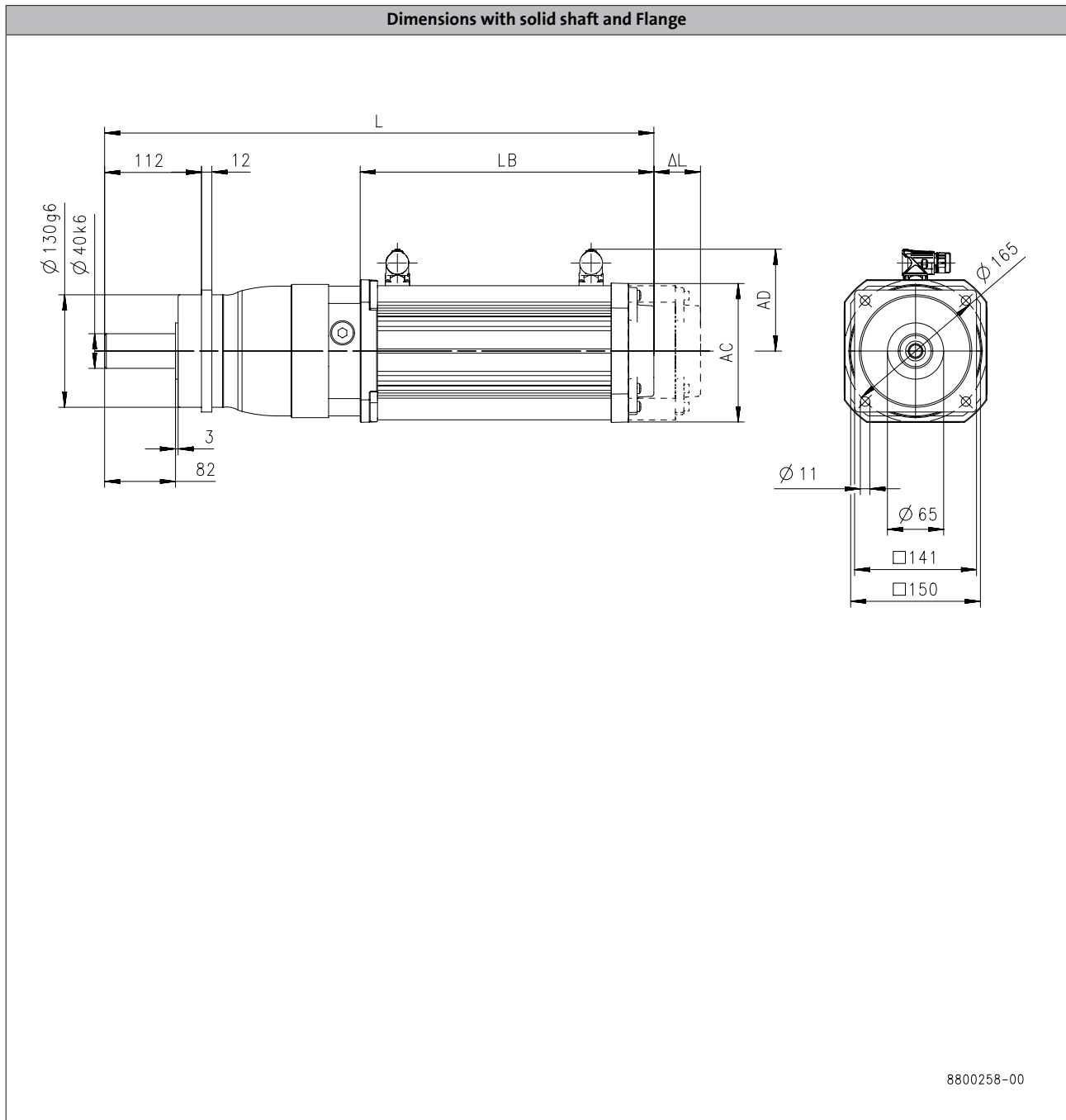

6.2.2

Product	MCA						
			13I41	14L20	14L41	17N23	17N41
Length							
Total length	L	[mm]	585		616		654
Motor length	LB	[mm]	270.5		301.5		339.5
Length of motor options	ΔL	[mm]	89		88.5		89.2
Motor diameter	AC	[mm]	130		142		165
Distance motor/connection	AD	[mm]	102		109		117.5

MPR planetary geared motors

Technical data



Dimensions, forced ventilated motors

MPR100, 1-stage gearboxes

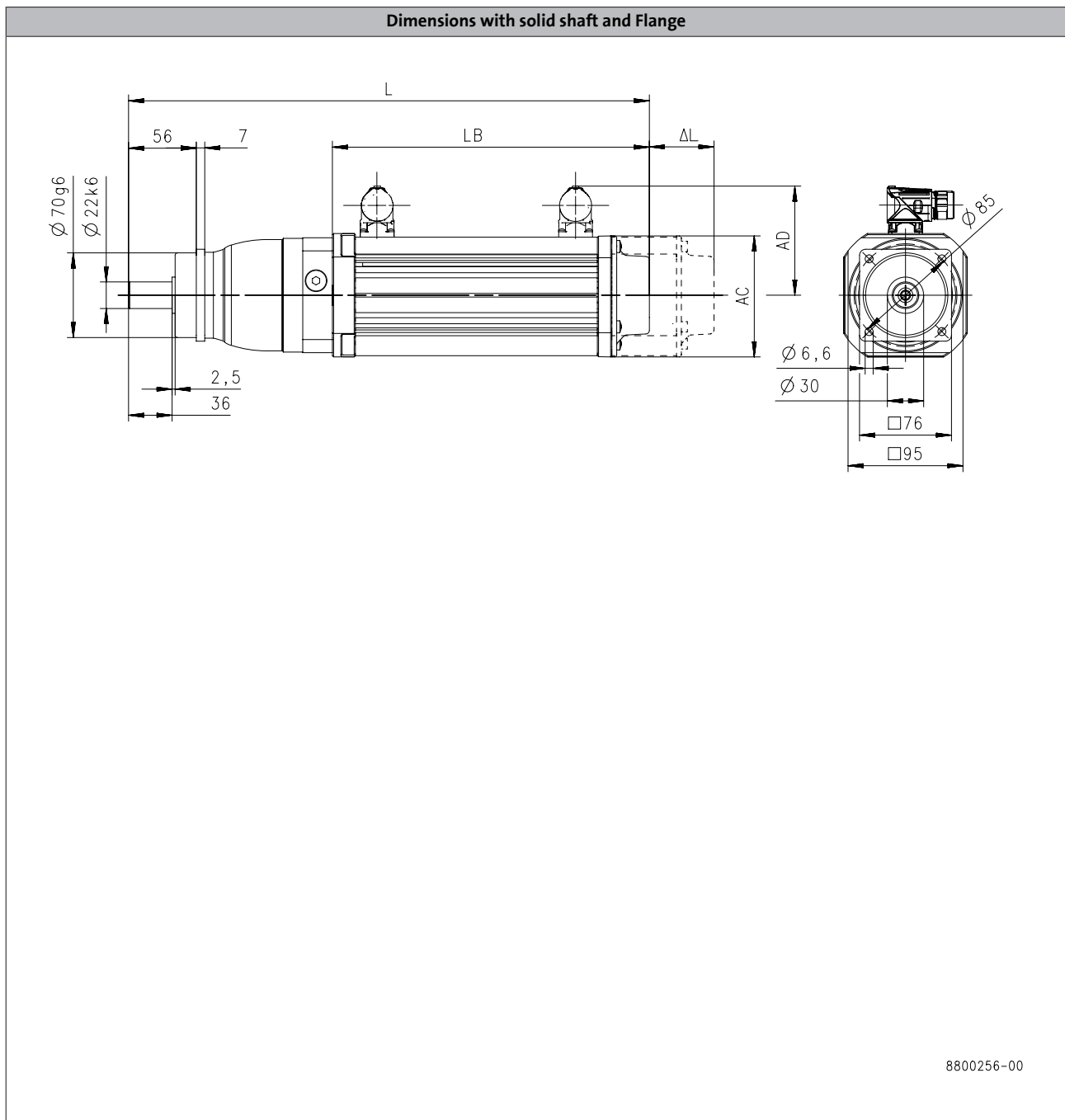

8800256-00

Product			MCA
			13I34
Length			
Total length	L	[mm]	507
Motor length	LB	[mm]	338.5
Length of motor options	Δ L	[mm]	89.5
Motor diameter	AC	[mm]	130
Distance motor/connection	AD	[mm]	102

MPR planetary geared motors

Technical data



Dimensions, forced ventilated motors

MPR200, 1-stage gearboxes

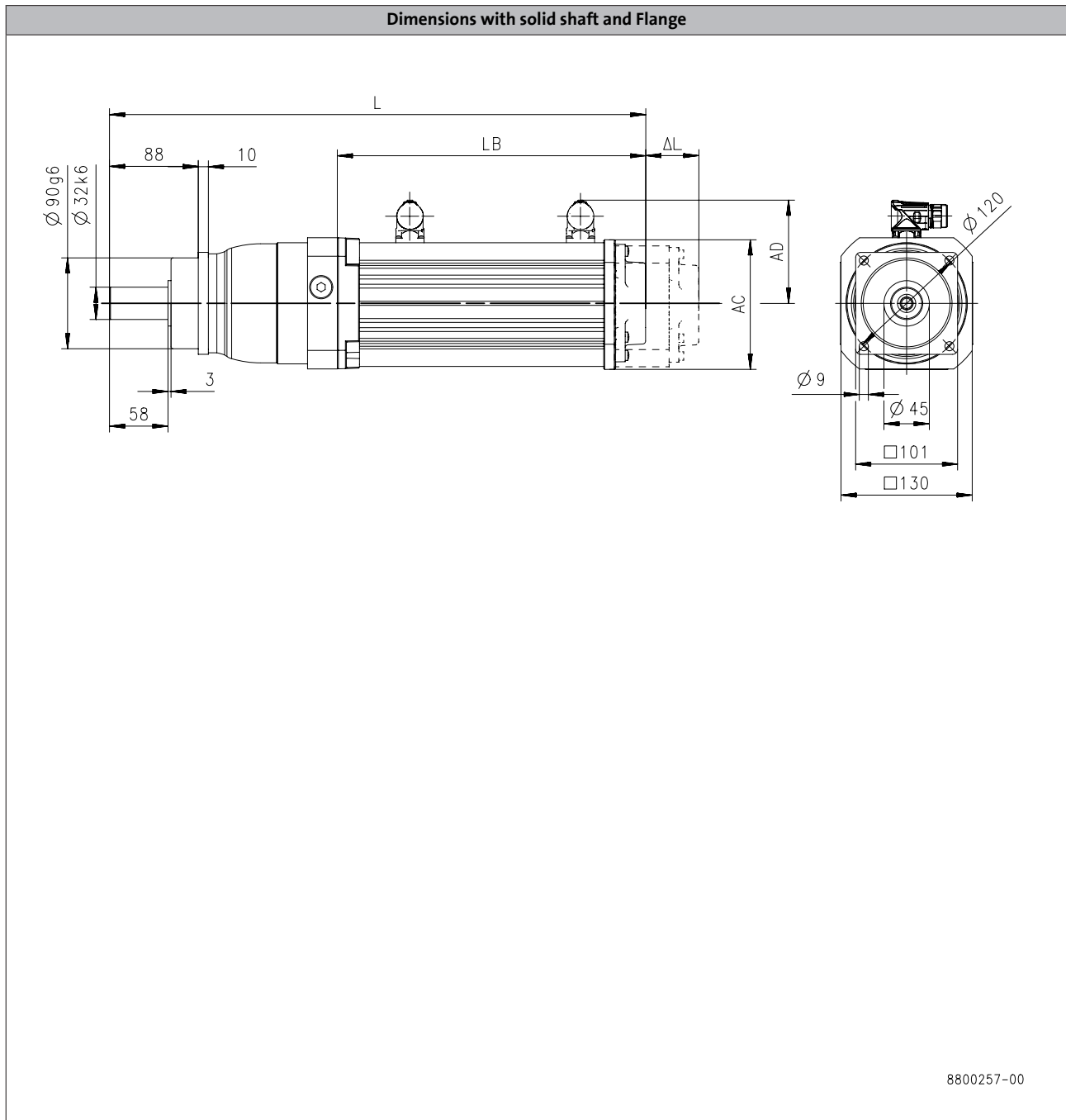

6.2.2

Product			MCA				
			13I34	14L16	14L35	17N17	17N35
Length							
Total length	L	[mm]	564	589		651	
Motor length	LB	[mm]	338.5	363.5		425.5	
Length of motor options	ΔL	[mm]	89.5	88.5		89	
Motor diameter	AC	[mm]	130	142		165	
Distance motor/connection	AD	[mm]	102	109		117.5	

MPR planetary geared motors

Technical data



Dimensions, forced ventilated motors

MPR200, 2-stage gearboxes

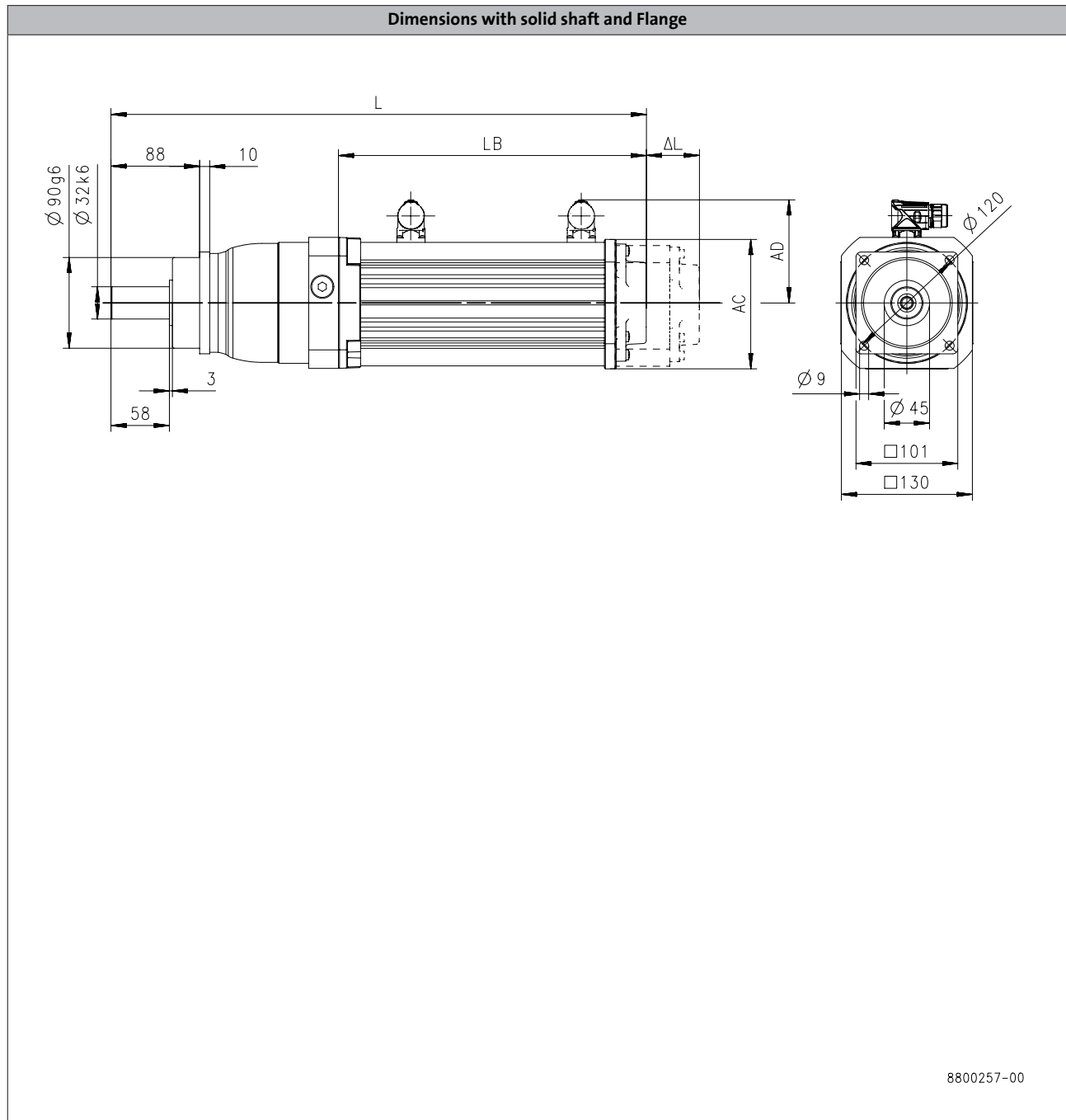

8800257-00

Product			MCA
			13I34
Length			
Total length	L	[mm]	578
Motor length	LB	[mm]	338.5
Length of motor options	Δ L	[mm]	89.5
Motor diameter	AC	[mm]	130
Distance motor/connection	AD	[mm]	102

MPR planetary geared motors

Technical data



Dimensions, forced ventilated motors

MPR300, 1-stage gearboxes

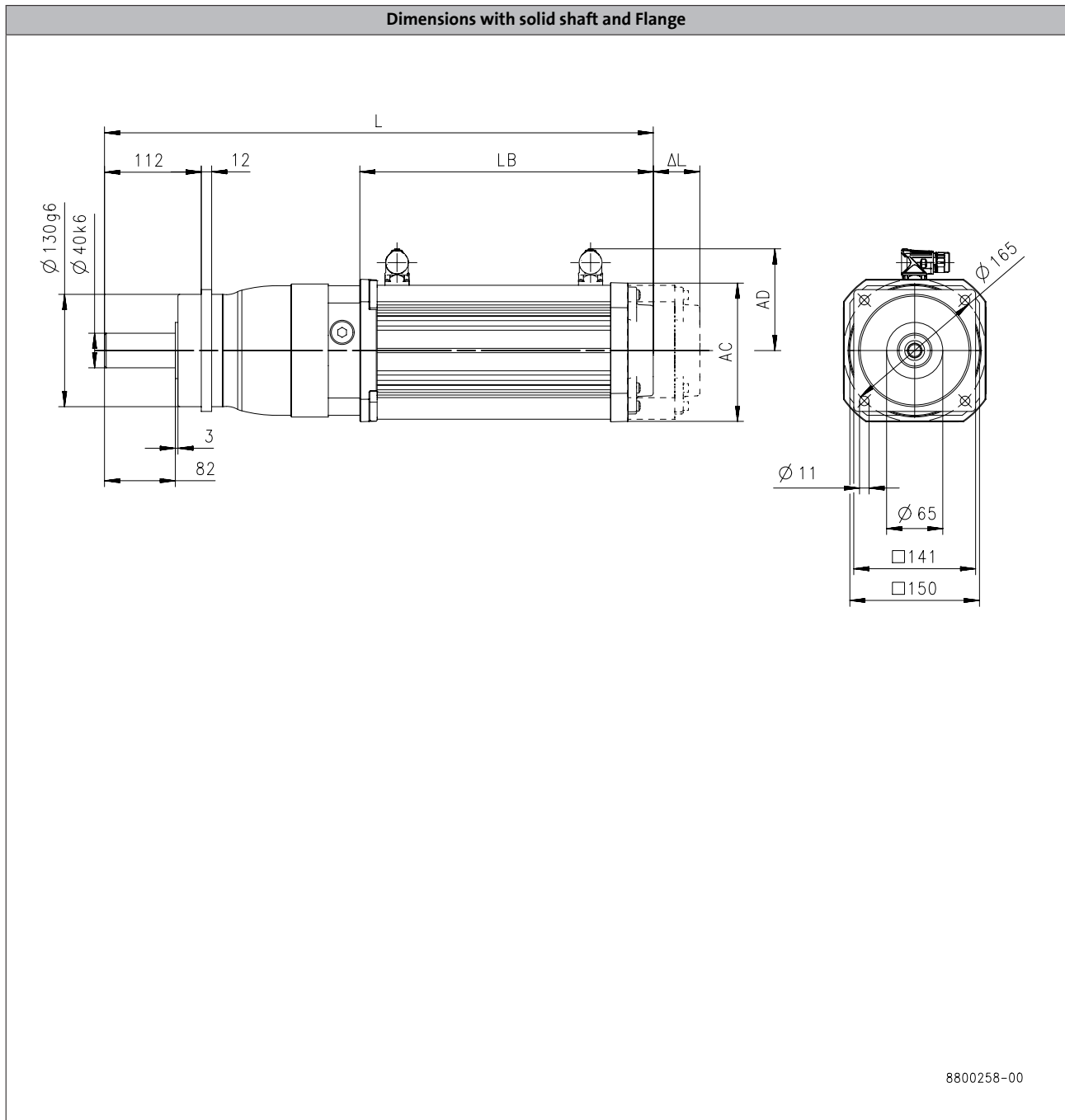

6.2.2

Product			MCA					
			14L16	14L35	17N17	17N35	19S17	19S35
Length								
Total length	L	[mm]	659		721		794	
Motor length	LB	[mm]	363.5		425.5		498	
Length of motor options	ΔL	[mm]	88.5		89		88.2	
Motor diameter	AC	[mm]	142		165		192	
Distance motor/connection	AD	[mm]	109		117.5		151	

MPR planetary geared motors

Technical data



Dimensions, forced ventilated motors

MPR300, 2-stage gearboxes

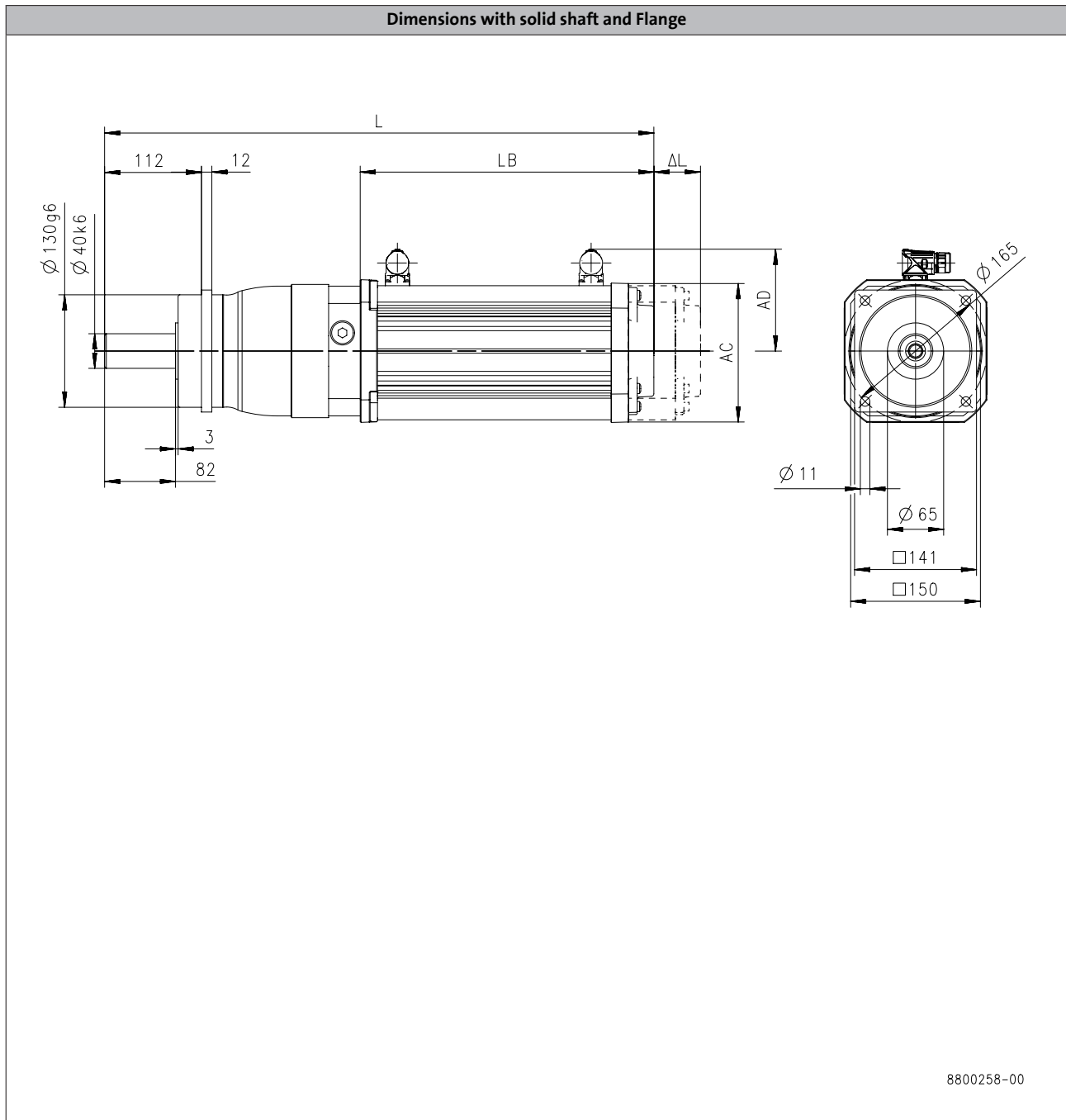

8800258-00

Product	MCA						
			13I34	14L16	14L35	17N17	17N35
Length							
Total length	L	[mm]	653		678		740
Motor length	LB	[mm]	338.5		363.5		425.5
Length of motor options	Δ L	[mm]	89.5		88.5		89
Motor diameter	AC	[mm]	130		142		165
Distance motor/connection	AD	[mm]	102		109		117.5

MPR planetary geared motors

Technical data



Weights, self-ventilated motors

1-stage gearboxes

				MCA				
				10I40	13I41	14L20 14L41	17N23 17N41	19S23 19S42
MPR	050	m	[kg]	8.5				
	100	m	[kg]	9.5	14			
	200	m	[kg]		18	22	30	
	300	m	[kg]			32	40	62

2-stage gearboxes

				MCA			
				10I40	13I41	14L20 14L41	17N23 17N41
MPR	100	m	[kg]	11			
	200	m	[kg]	15	19		
	300	m	[kg]		29	34	42

MPR planetary geared motors

Technical data



Weights, forced ventilated motors

1-stage gearboxes

				MCA			
				13I34	14L16 14L35	17N17 17N35	19S17 19S35
MPR	100	m	[kg]	15			
	200	m	[kg]	19	24	33	
	300	m	[kg]		34	43	66

2-stage gearboxes

				MCA		
				13I34	14L16 14L35	17N17 17N35
MPR	200	m	[kg]	20		
	300	m	[kg]	31	36	44

MPR planetary geared motors

Technical data



Surface and corrosion protection

For optimum protection of geared motors against ambient conditions, the surface and corrosion protection system (OKS) offers tailor-made solutions.

Various surface coatings combined with other protective measures ensure that the geared motors operate reliably even at high air humidity, in outdoor installations or in the presence of atmospheric impurities. Any colour from the RAL Classic collection can be chosen for the top coat. The geared motors are also available unpainted (no surface and corrosion protection).

Surface and corrosion protection	Applications	Measures
OKS-G (primed)	<ul style="list-style-type: none"> • Dependent on subsequent top coat applied 	<ul style="list-style-type: none"> • 2K PUR priming coat (grey) • Zinc-coated screws • Rust-free breather elements Optional measures <ul style="list-style-type: none"> • Stainless steel nameplate

Structure of surface coating

Surface and corrosion protection	Surface coating
	Structure
Without OKS(uncoated)	Dipping primed gearbox
OKS-G (primed)	Dipping primed gearbox 2K PUR priming coat

MPR planetary geared motors

Technical data

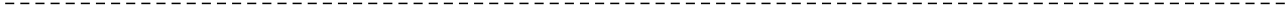

Gearboxes

MPR planetary gearbox

29 to 390 Nm



MPR planetary gearboxes

Contents



General information	List of abbreviations	6.2.3 - 5
	Product information	6.2.3 - 6
	Equipment	6.2.3 - 7
	The gearbox kit	6.2.3 - 8
	Functions and features	6.2.3 - 10
Technical data	Permissible radial and axial forces at output	6.2.3 - 11
	Backlash and torsional rigidity	6.2.3 - 12
	Speeds and torques	6.2.3 - 13
	Moments of inertia	6.2.3 - 15

MPR planetary gearboxes

Contents

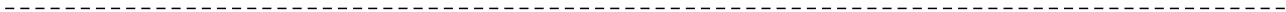

MPR planetary gearboxes

General information



List of abbreviations

$F_{ax,max}$	[N]	Max. axial force
$F_{rad,max}$	[N]	Max. radial force
i		Ratio
J	[kgcm ²]	Moment of inertia
m	[kg]	Mass

MPR planetary gearboxes

General information



Product information

The MPR/MPG planetary gearboxes feature a higher-than-average torsional stiffness combined with a backlash down to one angular minute. Their combination with MCS synchronous servo motors and MCA asynchronous servo motors creates flexible and particularly energy-efficient solutions which cover virtually every application.

Version

- Robust planetary gearbox with solid shaft (MPR) or flanged shaft (MPG)
- High precision for the application thanks to low backlash (min. ≤ 1 angular minutes)
- Efficient drive solutions with high efficiency (95 ... 97 %)
- Any mounting position which can be changed subsequently as well
- Enclosure IP65 (dust-tight, protection against water jets under any angle)

The product name

Gearbox type	Product range	Rated torque [Nm]	Product
Planetary gearbox	MPR	29	MPR050
		83	MPR100
		200	MPR200
		390	MPR300

MPR planetary gearboxes

General information



Equipment

Overview

The equipment includes all the options available as standard and all the built-on accessories of the product.

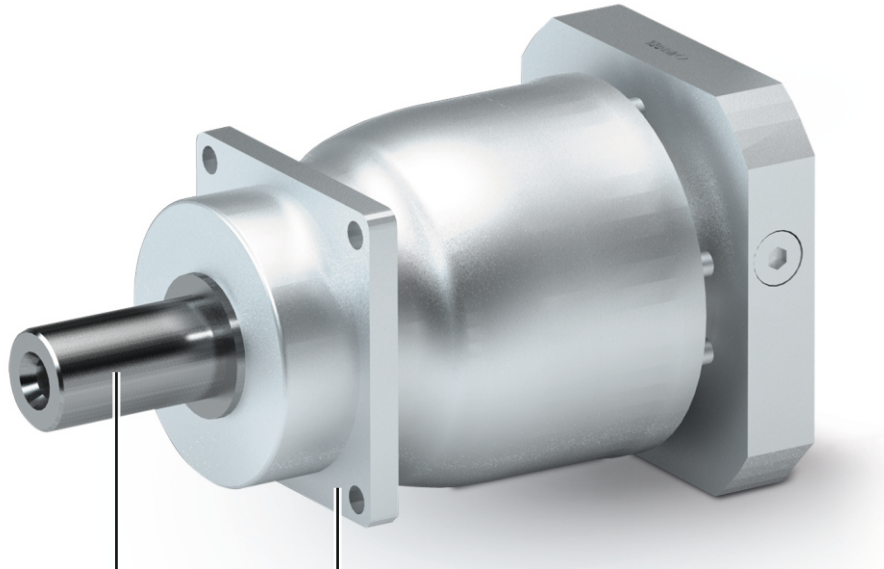

Output shaft

Solid shaft without keyway

Housing design

Flange with through holes

MPR planetary gearboxes

General information



The gearbox kit

Gearbox details

Product	MPR050	MPR100	MPR200	MPR300
Driven shaft				
Solid shaft without keyway [mm]	16x28	22x36	32x58	40x82
Design	Standard			
Gasket	NBR			
Bearing	Standard			
Housing				
Housing version	Without foot with centering			
Output flange				
Flange square [mm]	62	76	101	141
Lubricant				
Type	Mobil SHC 629			
Breather element	Without			
Backlash				
Backlash	Standard Reduced			

- Further information and installation feasibilities can be found in the Gearboxes chapter.

MPR planetary gearboxes

General information



The gearbox kit

Gearbox details

Solid shaft
 <p data-bbox="619 734 766 761">With centering</p>

MPR planetary gearboxes

General information



Functions and features

Product	MPR050	MPR100	MPR200	MPR300
Housing				
Design	Cylindrical shape			
Solid shaft				
Design	Without keyway			
Tolerance	k6			
Toothed parts				
Design	Helical cut teeth			
Ratios	Mathematically precise			
Shaft-hub joint				
	Force-fit, motor gearbox connected via clamping hub			
Lubricants				
Changing interval	Lubricated for life			
Quantities	Can be installed in any orientation			
Mechanical efficiency				
1-stage gearboxes [$\eta_{c=1}$]	0.97			
2-stage gearboxes [$\eta_{c=1}$]	0.95			
3-stage gearboxes [$\eta_{c=1}$]				

Direction of rotation

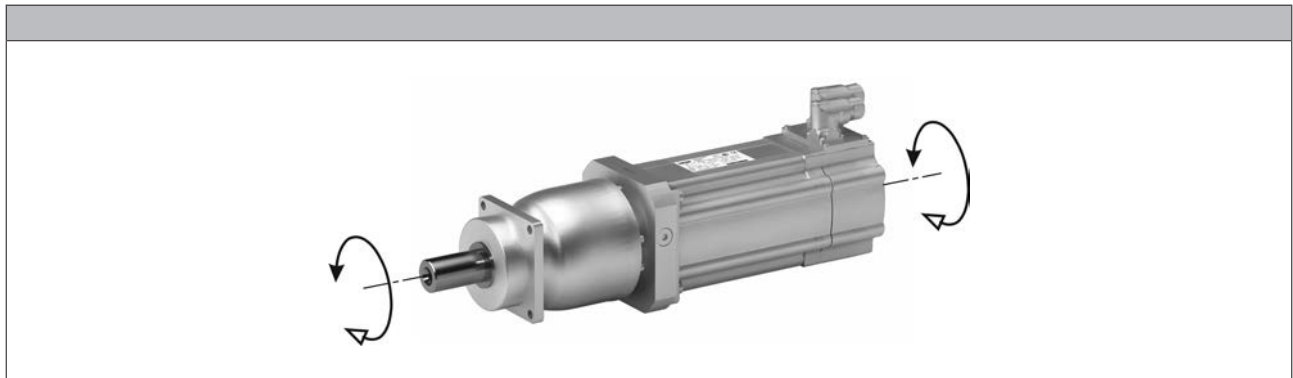

MPR planetary gearboxes

Technical data



Permissible radial and axial forces at output

Permissible radial force

$$F_{rad,per} = F_{rad,max} \text{ if } F_{ax} = 0$$

Permissible axial force

$$F_{ax,per} = F_{ax,max} \text{ if } F_{rad} = 0$$

- If F_{rad} and $F_{ax} \neq 0$, please contact Lenze.

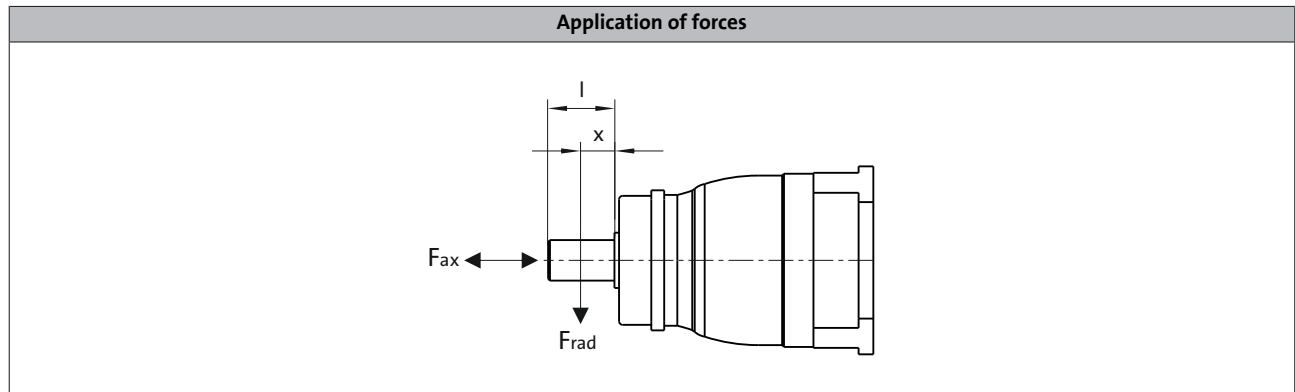

Product	n_2 [r/min]
	250

	Max. radial force, Solid shaft with flange	Max. axial force, Solid shaft with flange
	$F_{rad,max}$ [N]	$F_{ax,max}$ [N]
MPR050	2700	2400
MPR100	4000	3350
MPR200	6300	5650
MPR300	9450	9870

- Application of force F_{rad} : centre of shaft journal ($x = l/2$)
- $F_{ax,max}$ only valid with $F_{rad} = 0$

MPR planetary gearboxes

Technical data



Backlash and torsional rigidity

1-stage gearboxes

Product	Backlash	
	Standard [arcmin]	Reduced [arcmin]
MPR050	4.00	2.00
MPR100		
MPR200	3.00	1.00
MPR300		

2-stage gearboxes

Product	Backlash	
	Standard [arcmin]	Reduced [arcmin]
MPR050	6.00	4.00
MPR100		
MPR200	5.00	3.00
MPR300		

► Measured at output. Load 2 % of the rated torque value.

MPR planetary gearboxes

Technical data



Speeds and torques

- ▶ **Rated torque $M_{2, GN}$**
At rated speed, ambient temperature 20 °C and duty type S1.
- ▶ **Max. output torque $M_{2, max}$**
Max. 1000 cycles per hour permissible.
- ▶ **Emergency off torque $M_{2, not}$**
Max.1000 emergency switching off actions during gearbox service life
- ▶ **Max. gearbox input speed**
 $n_{1, max 50\%}$
Max. medium speed at 50 % rated torque
 $n_{1, max 100\%}$
Max. medium speed at 100 % rated torque
 $n_{1, max}$
Max. permissible speed

1-stage gearboxes

Product	Ratio i	Rated torque $M_{2, GN}$ [Nm]	Max. output torque $M_{2, max}$ [Nm]	Max. gearbox input speed			Emergency off-torque $M_{2, not}$ [Nm]
				$n_{1, max 50\%}$ [r/min]	$n_{1, max 100\%}$ [r/min]	$n_{1, max}$ [r/min]	
MPR050	3.000	20	32	3300	3300	6000	80
	4.000	29	44	3300	3300		110
	5.000	29	44	3300	3300		110
	7.000	29	44	3700	3700		107
	10.000	19	35	4000	4000		88
MPR100	3.000	56	90	2800	2800	6000	200
	4.000	83	120	2800	2800		275
	5.000	83	120	2800	2800		275
	7.000	83	120	2800	2800		275
	10.000	58	90	3100	3100		220
MPR200	3.000	135	230	2500	2500	4500	500
	4.000	200	330	2500	2500		690
	5.000	195	330	2500	2500		675
	7.000	190	300	2800	2800		640
	10.000	135	235	2800	2800		550
MPR300	3.000	290	400	2100	2100	4000	1000
	4.000	390	660	2100	2100		1400
	5.000	390	660	2100	2100		1400
	7.000	380	600	2300	2300		1400
	10.000	245	480	2600	2600		1100

MPR planetary gearboxes

Technical data



Speeds and torques

2-stage gearboxes

Product	Ratio i	Rated torque $M_{2,GN}$ [Nm]	Max. output torque $M_{2,max}$ [Nm]	Max. gearbox input speed			Emergency off-torque $M_{2,not}$ [Nm]
				$n_{1,max 50\%}$	$n_{1,max 100\%}$	$n_{1,max}$	
				[r/min]	[r/min]	[r/min]	
MPR050	12.000	20	32	4000	4000	6000	80
	16.000	29	44	4400	4400		110
	20.000	29	44	4400	4400		110
	25.000	29	44	4400	4400		110
	28.000	29	44	4400	4400		110
	35.000	29	44	4400	4400		110
	40.000	29	44	4400	4400		110
	50.000	29	44	4800	4800		110
	70.000	29	44	5500	5500		107
	100.000	19	35	5500	5500		88
MPR100	12.000	56	90	3100	3100	6000	200
	16.000	83	120	3500	3500		275
	20.000	83	120	3500	3500		275
	25.000	83	120	3500	3500		275
	28.000	83	120	3500	3500		275
	35.000	83	120	3500	3500		275
	40.000	76	120	3500	3500		275
	50.000	83	120	3800	3800		275
	70.000	83	120	4500	4500		275
	100.000	58	90	4500	4500		220
MPR200	12.000	135	230	2800	2800	4500	500
	16.000	200	330	3100	3100		690
	20.000	195	330	3100	3100		675
	25.000	195	330	3100	3100		675
	28.000	200	330	3100	3100		690
	35.000	195	330	3100	3100		675
	40.000	200	330	3100	3100		690
	50.000	195	330	3500	3500		675
	70.000	190	330	4200	4200		640
	100.000	135	235	4200	4200		550
MPR300	12.000	290	400	2600	2600	4000	1000
	16.000	390	660	2900	2900		1400
	20.000	390	660	2900	2900		1400
	25.000	390	660	2900	2900		1400
	28.000	390	660	2900	2900		1400
	35.000	390	660	2900	2900		1400
	40.000	390	660	2900	2900		1400
	50.000	390	660	3200	3200		1400
	70.000	380	600	3200	3200		1400
	100.000	245	480	3900	3900		1100

6.2.3

MPR planetary gearboxes

Technical data



Moments of inertia

- ▶ The moments of inertia relate to the drive shaft of the gearbox.
- ▶ The total moment of inertia is calculated by adding the values of the gearbox, motor and accessories.

1-stage gearboxes

Product	Dimensions	Ratio	Moment of inertia
	Motor shaft diameter		
	d	i	J
	[mm]		[kgcm ²]
MPR050	11	3.000	0.330
	11	4.000	0.240
	11	5.000	0.200
	11	7.000	0.180
	11	10.000	0.160
	14	3.000	0.360
	14	4.000	0.270
	14	5.000	0.230
	14	7.000	0.210
	14	10.000	0.190
	19	3.000	0.530
	19	4.000	0.440
	19	5.000	0.400
	19	7.000	0.340
19	10.000	0.330	
MPR100	14	3.000	1.070
	14	4.000	0.740
	14	5.000	0.620
	14	7.000	0.520
	14	10.000	0.470
	19	3.000	1.210
	19	4.000	0.880
	19	5.000	0.760
	19	7.000	0.670
	19	10.000	0.620
	24	3.000	1.920
	24	4.000	1.590
	24	5.000	1.470
	24	7.000	1.370
24	10.000	1.320	
MPR200	19	3.000	4.480
	19	4.000	3.230
	19	5.000	2.780
	19	7.000	2.420
	19	10.000	2.230

Product	Dimensions	Ratio	Moment of inertia
	Motor shaft diameter		
	d	i	J
	[mm]		[kgcm ²]
MPR200	24	3.000	5.000
	24	4.000	3.750
	24	5.000	3.300
	24	7.000	2.940
	24	10.000	2.750
	28	3.000	6.800
	28	4.000	5.560
	28	5.000	5.100
	28	7.000	4.740
	28	10.000	4.550
	38	3.000	8.940
	38	4.000	7.690
	38	5.000	7.240
	38	7.000	6.850
38	10.000	6.670	
MPR300	24	3.000	13.540
	24	4.000	9.720
	24	5.000	8.270
	24	7.000	7.140
	24	10.000	6.460
	28	3.000	15.300
	28	4.000	11.490
	28	5.000	10.040
	28	7.000	8.890
	28	10.000	8.220
	38	3.000	16.590
	38	4.000	12.780
	38	5.000	11.330
	38	7.000	10.160
38	10.000	9.480	

MPR planetary gearboxes

Technical data



Moments of inertia

2-stage gearboxes

Product	Dimensions	Ratio	Moment of inertia
	Motor shaft diameter		
	d	i	J
	[mm]		[kgcm ²]
MPR050	11	12.000	0.210
	11	16.000	0.210
	11	20.000	0.180
	11	25.000	0.180
	11	28.000	0.170
	11	35.000	0.170
	11	40.000	0.160
	11	50.000	0.160
	11	70.000	0.160
	11	100.000	0.160
	14	12.000	0.250
	14	16.000	0.240
	14	20.000	0.210
	14	25.000	0.210
	14	28.000	0.200
	14	35.000	0.200
	14	40.000	0.190
	14	50.000	0.190
14	70.000	0.190	
14	100.000	0.190	
MPR100	11	12.000	0.250
	11	16.000	0.230
	11	20.000	0.190
	11	25.000	0.190
	11	28.000	0.170
	11	35.000	0.170
	11	40.000	0.160
	11	50.000	0.160
	11	70.000	0.160
	11	100.000	0.160
	14	12.000	0.290
	14	16.000	0.260
	14	20.000	0.220
	14	25.000	0.220
	14	28.000	0.200
	14	35.000	0.200
	14	40.000	0.190
	14	50.000	0.190
14	70.000	0.190	
14	100.000	0.190	
MPR200	14	12.000	0.840
	14	16.000	0.760
	14	20.000	0.610
	14	25.000	0.600
	14	28.000	0.520
	14	35.000	0.510
	14	40.000	0.470
	14	70.000	0.460

Product	Dimensions	Ratio	Moment of inertia
	Motor shaft diameter		
	d	i	J
	[mm]		[kgcm ²]
MPR200	14	100.000	0.460
	19	12.000	0.980
	19	16.000	0.900
	19	20.000	0.760
	19	25.000	0.740
	19	28.000	0.660
	19	35.000	0.650
	19	40.000	0.620
	19	50.000	0.610
	19	70.000	0.610
MPR300	19	100.000	0.600
	19	12.000	2.700
	19	16.000	2.460
	19	20.000	2.260
	19	25.000	2.200
	19	28.000	2.140
	19	35.000	2.120
	19	40.000	2.110
	19	50.000	2.080
	19	70.000	2.070
	19	100.000	2.060
	24	12.000	3.220
	24	16.000	2.980
	24	20.000	2.780
	24	25.000	2.720
	24	28.000	2.660
	24	35.000	2.630
	24	40.000	2.620
24	50.000	2.590	
24	70.000	2.580	
24	100.000	2.580	
28	12.000	5.020	
28	16.000	4.780	
28	20.000	4.580	
28	25.000	4.530	
28	28.000	4.460	
28	35.000	4.430	
28	40.000	4.420	
28	50.000	4.390	
28	70.000	4.380	
28	100.000	4.380	

6.2.3

Gearboxes

MPG planetary-geared motors

6 ... 387 Nm (synchronous servo motors)

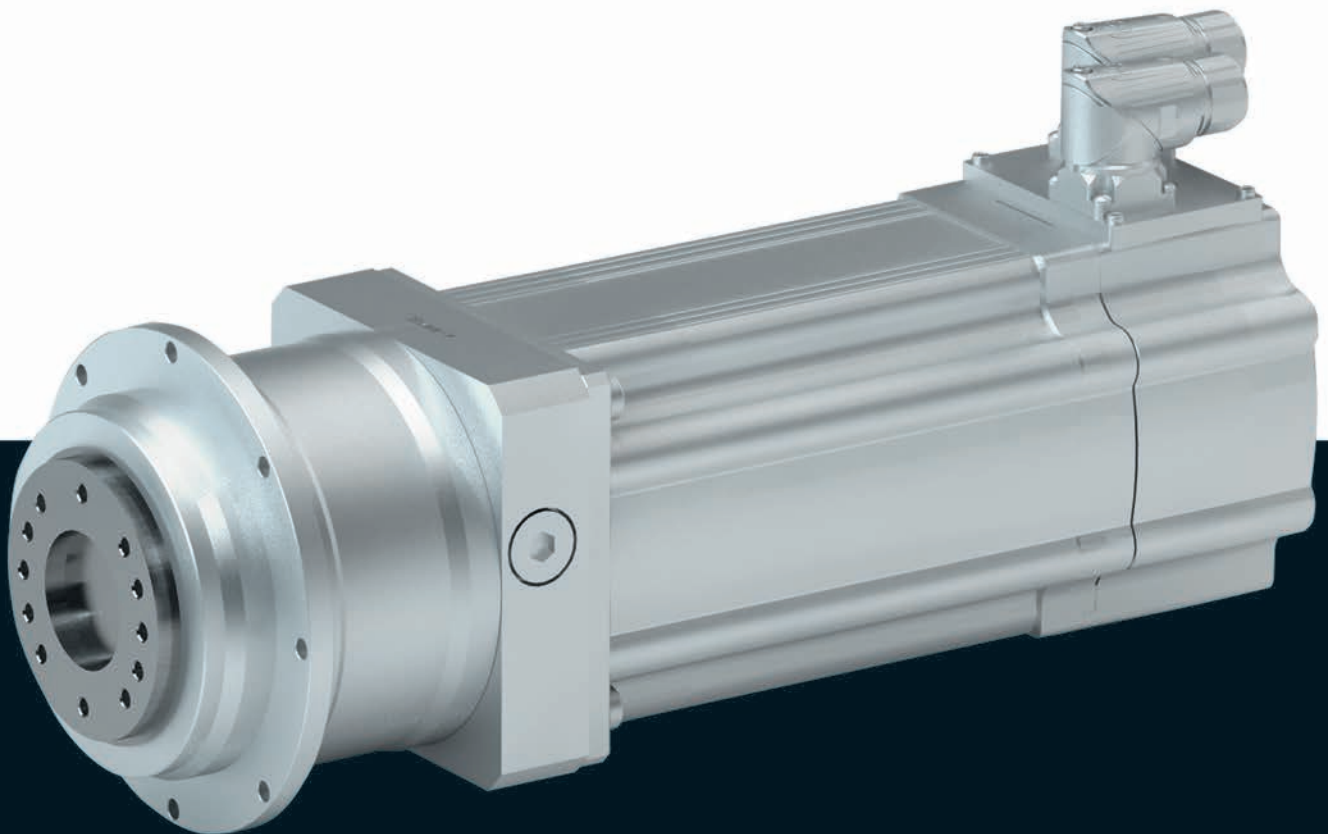

MPG planetary geared motors



Contents

General information	List of abbreviations	6.2.4 - 5
	Product information	6.2.4 - 6
	Equipment	6.2.4 - 7
	The gearbox kit	6.2.4 - 9
	Dimensioning	6.2.4 - 14
Technical data	Selection tables, notes	6.2.4 - 17
	Selection tables	6.2.4 - 18
	Dimensions, notes	6.2.4 - 36
	Dimensions, self-ventilated motors	6.2.4 - 37
	Dimensions, forced ventilated motors	6.2.4 - 52
	Weights, self-ventilated motors	6.2.4 - 60
	Weights, forced ventilated motors	6.2.4 - 61
	Surface and corrosion protection	6.2.4 - 62

MPG planetary geared motors

Contents

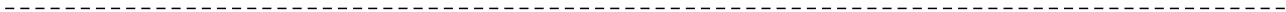

MPG planetary geared motors

General information



List of abbreviations

c		Load capacity
i		Ratio
J	[kgcm ²]	Moment of inertia
m	[kg]	Mass
M ₂	[Nm]	Output torque
M _{2, max}	[Nm]	Max. output torque
n _{2, eto}	[r/min]	Transition speed
n _{2, th}	[r/min]	Thermal limit speed

CCC	China Compulsory Certificate
CE	Communauté Européenne
CSA	Canadian Standards Association
cURus	Combined certification marks of UL for the USA and Canada
DIN	Deutsches Institut für Normung e.V.
EMC	Electromagnetic compatibility
EN	European standard
GOST	Certificate for Russian Federation
IEC	International Electrotechnical Commission
IM	International Mounting Code
IP	International Protection Code
NEMA	National Electrical Manufacturers Association
UL	Underwriters Laboratory Listed Product
UR	Underwriters Laboratory Recognized Product
VDE	Verband deutscher Elektrotechniker (Association of German Electrical Engineers)

MPG planetary geared motors



General information

Product information

The combination of Vogel MPR/MPG planetary gearboxes and Lenze servo motors is the optimum solution for dynamic or highly dynamic applications requiring the highest precision. These solutions cater to the requirements such as those encountered on a daily basis in the printing and packaging industry, as well as in the fields of handling and robot technology, filling and materials handling technology and, in many cases, also general engineering.

The MPR/MPG planetary gearboxes feature a higher-than-average torsional stiffness combined with a backlash down to one angular minute. Their combination with MCS synchronous servo motors and MCA asynchronous servo motors creates flexible and particularly energy-efficient solutions which cover virtually every application.

Version

- Robust planetary gearbox with solid shaft (MPR) or flanged shaft (MPG)
- High precision for the application thanks to low backlash (min. ≤ 1 angular minutes)
- Efficient drive solutions with high efficiency (95 ... 97 %)
- Any mounting position which can be changed subsequently as well
- Enclosure IP65 (dust-tight, protection against water jets under any angle)

The product name

Gearbox type	Product range	Rated torque [Nm]	Product
Planetary gearbox	MPG	29	MPG050
		83	MPG100
		200	MPG200
		390	MPG300

MPG planetary geared motors

General information



Equipment

Overview

The equipment includes all the options available as standard and all the built-on accessories of the product.

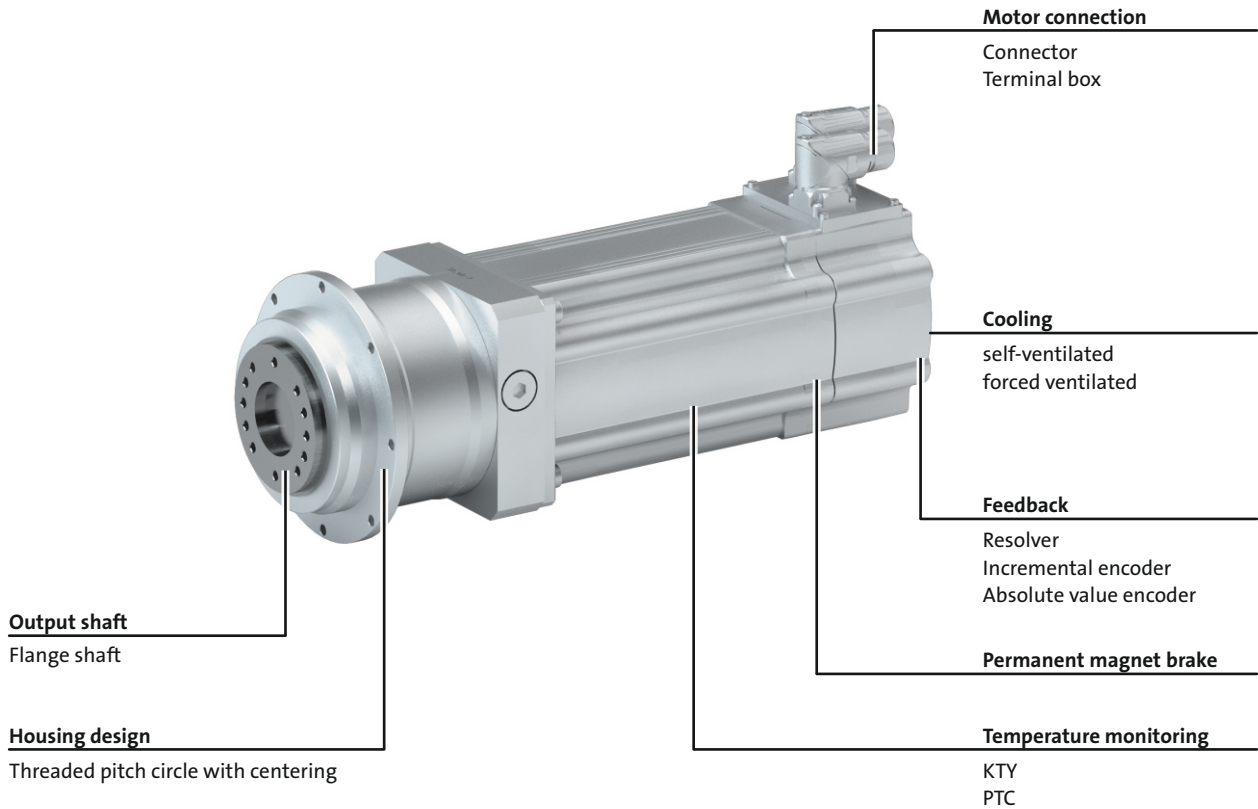

MPG planetary geared motors

General information



MPG planetary geared motors

General information



The gearbox kit

Geared motor

Product	MPG050	MPG100	MPG200	MPG300
Motor type	Synchronous servo motor			
Servo motor				
0.6 - 1.5 Nm	MCS06			
2.3 - 4.5 Nm	MCS09			
5.5 - 17 Nm	MCS12			
9.2 - 42 Nm		MCS14		
27 - 72 Nm			MCS19	
Technical data				
Output torque	See selection table			
Output speed	See selection table			
Ratio	See selection table			
Load capacity	See selection table			
Moment of inertia	See selection table			
Mounting position				
Standard	Any			
Colour				
	primed (RAL 9005M, matt jet black)			
Surface and corrosion protection				
	Without OKS(uncoated) OKS-G (primed)			

MPG planetary geared motors

General information



The gearbox kit

Motor details

Product	MCS				
	06C41	09L41	12H14	14D14	19F12
	06C60	09D41	12L17	14L14	19P12
	06F41	09L51	12D17	14H12	19J12
	06F60	09D60	12L20	14P11	19P14
	06I41	09F38	12H15	14P14	19J14
	06I60	09F60	12D20	14D15	19F14
		09H41	12D35	14H15	19J29
		09H60	12H34	14L15	19P29
			12L39	14H28	19F29
			12D41	14P26	19J30
			12H35	14L30	19F30
			12L41	14D30	19P30
				14H32	
				14P32	
				14D36	
				14L32	
Connection type	Plug connectors		Plug connectors Terminal box		
Permanent magnet holding brake					
Rated torque [Nm]	2.2	8.0	12	22	37
Brake voltage [V]	DC 24				
Feedback	With absolute value encoder With incremental encoder With resolver				
Cooling	Self-ventilated		Self-ventilated Forced-ventilated		
Temperature monitoring	KTY83-110 thermal detector		KTY83-110 thermal detector PTC thermistor		
Approval	cURus GOST_R UkrSepro				
Degree of protection	IP54 IP65				

- Further information and installation feasibilities can be found in the Motors chapter.







MPG planetary geared motors

General information



The gearbox kit

Motor details

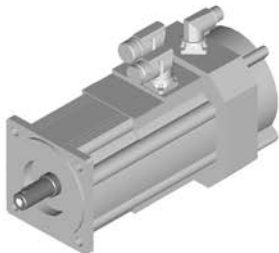
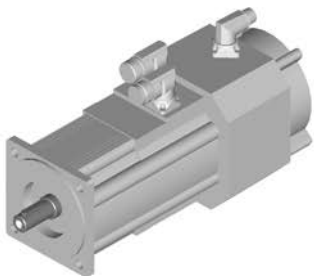
Connection type		
 Plug connectors	 Terminal box	
Cooling: self-ventilated		
 With resolver	 With permanent magnet brake	 With feedback With feedback and permanent magnet brake
Cooling: forced ventilated		
 With resolver	 With permanent magnet brake	 With feedback With feedback and permanent magnet brake

6.2.4

MPG planetary geared motors

General information



The gearbox kit

Gearbox details

Product	MPG050	MPG100	MPG200	MPG300
Driven shaft				
Flange shaft with threaded holes	40	63	80	100
Design	Standard			
Gasket	NBR			
Bearing	Standard			
Housing				
Housing version	Without foot with centering			
Output flange				
flange diameter [mm]	86	118	145	179
Lubricant				
Type	Mobil SHC 629			
Breather element	Without			
Backlash				
Backlash	Standard Reduced			

- Further information and installation feasibilities can be found in the Gearboxes chapter.

MPG planetary geared motors

General information



The gearbox kit

Gearbox details

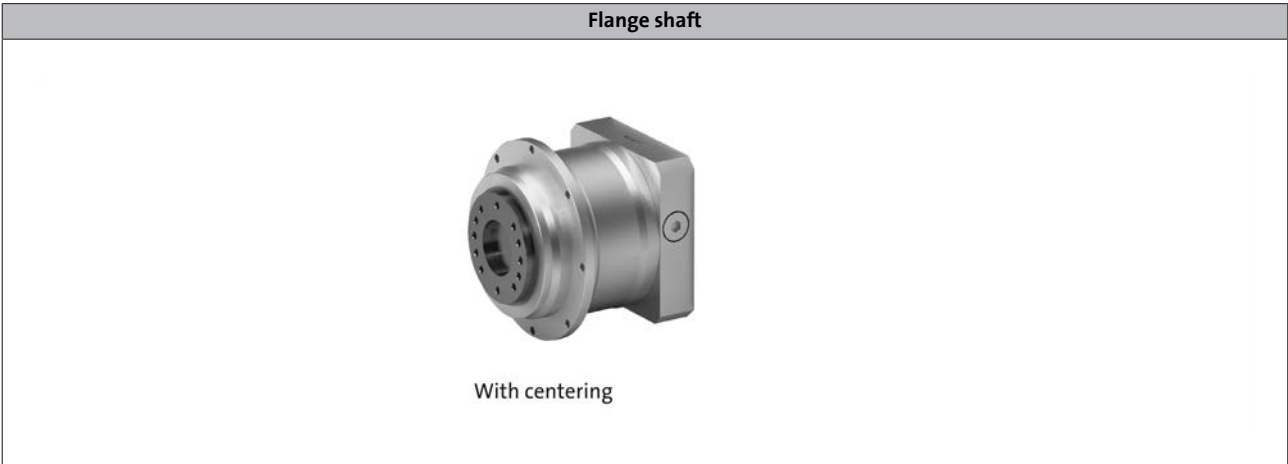

MPG planetary geared motors



General information

Dimensioning

General information about the data provided in this catalogue

The powers, torques and speeds specified in this catalogue are rounded values and are valid under the following conditions:

- Operating time/day = 8 h (100% OT)
- Duty class I for up to 10 switching operations/h
- Mounting positions and designs in this catalogue
- Standard lubricant
- $T_{amb} = 30\text{ °C}$ for gearboxes,
 $T_{amb} = 40\text{ °C}$ for motors (in accordance with EN 60034)
- Site altitude $< = 1000\text{ m amsl}$
- The selection tables provide the permissible mechanical powers and torques. For notes on the thermal power limit, see chapter drive dimensioning.
- The rated power specified for motors and geared motors applies to operating mode S1 (in accordance with EN 60034).

Under different operating conditions, the values obtained may vary from those listed here.

In the case of extreme operating conditions, please consult your Lenze sales office.

MPG planetary geared motors



General information

Dimensioning

Load capacity and application factor

Load capacity c of gearbox

Rated value for the load capacity of Lenze geared motors.

- c is the ratio of the permissible rated torque of the gearbox to the rated torque supplied by the drive component (e.g. the built-in Lenze motor).
- The value of c must always be greater than the value of the application factor k calculated for the application.

Application factor k (according to DIN 3990)

Takes into account the influence of temporally variable loads which are actually present during the anticipated operating time of gearboxes and geared motors.

k is determined by:

- the type of load
- the load intensity
- temporal influences

Duty class	Load type
I	Smooth operation, small or light jolts
II	Uneven operation, average jolts
III	Uneven operation, severe jolts and/or alternating load

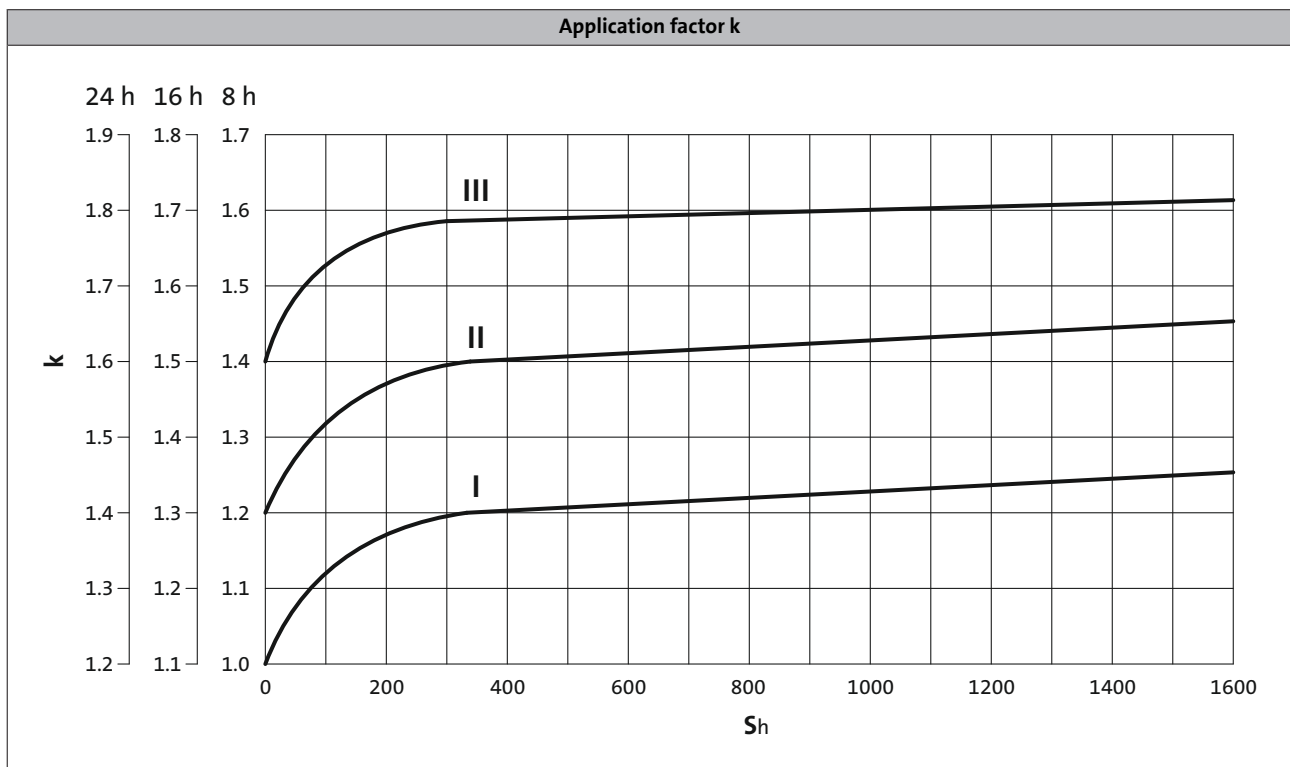

► S_h = switchings/h

MPG planetary geared motors

General information



Dimensioning

Weights

The values given in the tables consider the following gearbox/motor combination:

- Gearbox with solid shaft including lubricant amount
- Motor with feedback

For versions deviating from this, additional weights have to be considered.

The respective values can be found for:

- Geared motors with feedback
 - > Chapter: Geared motors/Technical data
- Motor options: Brake
 - > Chapter: Motors/Accessories

Moments of inertia

The given moments of inertia of the gearbox refer to the drive shaft. The influence of the ratio (i^2) has been considered in the data.

When the total moment of inertia of the geared motor is calculated, the values of the geared motors and the brake have to be added.

The respective values can be found for:

- Geared motors with feedback
 - > Chapter: Geared motors/Technical data/Selection tables
- Motor options: Brake
 - > Chapter: Motors/Accessories

MPG planetary geared motors



Technical data

Selection tables, notes

Notes on the selection tables

The selection tables show the available combinations of gearbox type, number of stages, ratio and motor. They are used only to provide basic orientation.

The following legend indicates the structure of the selection tables.

Number of the gear stage of the gearbox



2-stage gearboxes

Inverter operation						i	Product		Cooling	
M _{2, max} [Nm]	n _{2, th} [r/min]	M ₂ [Nm]	n _{2, eto} [r/min]	c	J [kgcm ²]		MPG	MCS		
29	275	7	275	3.9	0.300	16.000	050	06C60	Selbst	39
29	275	14	275	2.1	0.400	16.000	050	06F60	Selbst	39
29	275	18	275	1.6	0.500	16.000	050	06I60	Selbst	39
29	275	27	275	1.1	1.300	16.000	050	09D60	Selbst	39

For operating mode S1
Torque M₂ and
thermal output speed n_{2, th}

For operating mode S2, S3 und S6
Max. permissible acceleration torque of geared
motor M_{2, max} and
output speed n_{2, eto}

Moment of inertia of
geared motor

Ratio i

Product
Gearbox

Product
Motor

Type of
motor cooling

Page number
for dimensions

Load capacity of the gearbox
c is the ratio between the permissible rated torque of the
gearbox and the rated torque of the three-phase AC
motor (converted to the driven shaft).
c must be always higher than the service factor k
determined for the application k.

$$c = \frac{M_{2, zul}}{M_{1N} \cdot i \cdot \eta_{Getr}} > k$$

MPG planetary geared motors

Technical data



Selection tables

1-stage gearboxes

Inverter operation						i	Product		Cooling	
M _{2, max} [Nm]	n _{2, th} [r/min]	M ₂ [Nm]	n _{2, eto} [r/min]	c	J [kgcm ²]		MPG	MCS		
19	400	5	400	4.0	0.300	10.000	050	06C60	natural	37
19	400	6	400	3.3	0.300	10.000	050	06C41	natural	37
19	400	9	400	2.2	0.400	10.000	050	06F60	natural	37
19	400	12	400	1.6	0.400	10.000	050	06F41	natural	37
19	400	12	400	1.6	0.500	10.000	050	06I60	natural	37
19	400	15	400	1.3	0.500	10.000	050	06I41	natural	37
19	400	17	400	1.1	1.300	10.000	050	09D60	natural	37
21	660	6	660	5.0	0.400	5.000	050	06F41	natural	37
24	825	6	825	5.0	0.500	4.000	050	06I41	natural	37
29	825	7	825	4.3	1.400	4.000	050	09D60	natural	37
29	825	9	825	3.2	1.400	4.000	050	09D41	natural	37
29	825	9	825	3.1	1.800	4.000	050	09F60	natural	37
29	825	12	825	2.5	2.200	4.000	050	09H60	natural	37
29	825	12	825	2.5	1.800	4.000	050	09F38	natural	37
29	825	14	825	2.1	3.100	4.000	050	09L51	natural	37
29	825	15	825	2.0	2.200	4.000	050	09H41	natural	37
29	825	16	825	1.8	4.400	4.000	050	12D41	natural	37
29	825	17	825	1.7	3.100	4.000	050	09L41	natural	37
29	825	23	825	1.3	4.400	4.000	050	12D35	forced	52
29	660	6	660	5.0	0.500	5.000	050	06I60	natural	37
29	660	7	660	4.0	0.500	5.000	050	06I41	natural	37
29	660	8	660	3.4	1.300	5.000	050	09D60	natural	37
29	660	11	660	2.5	1.300	5.000	050	09D41	natural	37
29	660	12	660	2.5	1.700	5.000	050	09F60	natural	37
29	660	15	660	2.0	2.100	5.000	050	09H60	natural	37
29	660	15	660	2.0	1.700	5.000	050	09F38	natural	37
29	660	17	660	1.7	3.000	5.000	050	09L51	natural	37
29	660	18	660	1.6	2.100	5.000	050	09H41	natural	37
29	660	21	660	1.4	4.400	5.000	050	12D41	natural	37
29	660	22	660	1.3	3.000	5.000	050	09L41	natural	37
29	660	29	660	1.0	4.400	5.000	050	12D35	forced	52
29	529	6	529	4.7	0.400	7.000	050	06F60	natural	37
29	529	8	529	3.5	0.400	7.000	050	06F41	natural	37
29	529	8	529	3.6	0.500	7.000	050	06I60	natural	37
29	529	10	529	2.8	0.500	7.000	050	06I41	natural	37
29	529	12	529	2.4	1.300	7.000	050	09D60	natural	37
29	529	16	529	1.8	1.300	7.000	050	09D41	natural	37
29	529	16	529	1.8	1.700	7.000	050	09F60	natural	37
29	529	21	529	1.4	2.100	7.000	050	09H60	natural	37
29	529	21	529	1.4	1.700	7.000	050	09F38	natural	37

6.2.4

MPG planetary geared motors



Technical data

Selection tables

1-stage gearboxes

Inverter operation						i	Product		Cooling	
M _{2, max} [Nm]	n _{2, th} [r/min]	M ₂ [Nm]	n _{2, eto} [r/min]	c	J [kgcm ²]		MPG	MCS		
29	529	24	529	1.2	3.000	7.000	050	09L51	natural	37
29	529	26	529	1.1	2.100	7.000	050	09H41	natural	37
29	529	29	529	1.0	4.300	7.000	050	12D41	natural	37
29	488	21	488	1.4	4.400	4.000	050	12D20	natural	37
29	488	21	488	1.4	4.400	4.000	050	12D20	natural	37
29	413	27	413	1.1	4.400	4.000	050	12D17	forced	52
29	390	26	390	1.1	4.400	5.000	050	12D20	natural	37
29	390	26	390	1.1	4.400	5.000	050	12D20	natural	37
58	310	17	310	3.4	1.600	10.000	100	09D60	natural	40
58	310	23	310	2.5	1.600	10.000	100	09D41	natural	40
58	310	23	310	2.5	2.000	10.000	100	09F60	natural	40
58	310	29	310	2.0	2.400	10.000	100	09H60	natural	40
58	310	30	310	2.0	2.000	10.000	100	09F38	natural	40
58	310	35	310	1.7	3.300	10.000	100	09L51	natural	40
58	310	37	310	1.6	2.400	10.000	100	09H41	natural	40
58	310	41	310	1.4	4.600	10.000	100	12D41	natural	40
58	310	43	310	1.3	3.300	10.000	100	09L41	natural	40
58	310	58	310	1.0	4.600	10.000	100	12D35	forced	53
58	195	52	195	1.1	4.600	10.000	100	12D20	natural	40
58	195	52	195	1.1	4.600	10.000	100	12D20	natural	40
65	400	16	400	5.2	1.700	7.000	100	09D41	natural	40
69	700	23	700	3.6	5.000	4.000	100	12D35	forced	53
69	413	27	413	3.1	5.000	4.000	100	12D17	forced	53
70	700	16	700	5.0	5.000	4.000	100	12D41	natural	40
70	488	21	488	4.0	5.000	4.000	100	12D20	natural	40
70	488	21	488	4.0	5.000	4.000	100	12D20	natural	40
73	560	15	560	5.6	2.200	5.000	100	09F38	natural	40
78	700	15	700	5.7	2.800	4.000	100	09H41	natural	40
83	700	17	700	4.8	3.700	4.000	100	09L41	natural	40
83	700	29	700	2.9	9.800	4.000	100	14D36	natural	40
83	700	29	700	2.8	8.300	4.000	100	12H35	natural	40
83	700	31	700	2.7	8.300	4.000	100	12H30	natural	40
83	700	41	700	2.0	9.800	4.000	100	14D30	forced	53
83	700	41	700	2.0	8.300	4.000	100	12H34	forced	53
83	700	43	700	1.9	12.000	4.000	100	12L41	natural	40
83	700	54	700	1.5	12.000	4.000	100	12L39	forced	53
83	560	15	560	5.7	2.600	5.000	100	09H60	natural	40
83	560	17	560	4.8	3.500	5.000	100	09L51	natural	40
83	560	18	560	4.5	2.600	5.000	100	09H41	natural	40
83	560	21	560	4.0	4.900	5.000	100	12D41	natural	40

6.2.4

MPG planetary geared motors

Technical data



Selection tables

1-stage gearboxes

Inverter operation						i	Product		Cooling	
M _{2, max} [Nm]	n _{2, th} [r/min]	M ₂ [Nm]	n _{2, eto} [r/min]	c	J [kgcm ²]		MPG	MCS		
83	560	22	560	3.8	3.500	5.000	100	09L41	natural	40
83	560	29	560	2.9	4.900	5.000	100	12D35	forced	53
83	560	36	560	2.3	9.700	5.000	100	14D36	natural	40
83	560	37	560	2.3	8.200	5.000	100	12H35	natural	40
83	560	39	560	2.1	8.200	5.000	100	12H30	natural	40
83	560	51	560	1.6	9.700	5.000	100	14D30	forced	53
83	560	51	560	1.6	8.200	5.000	100	12H34	forced	53
83	560	54	560	1.5	11.000	5.000	100	12L41	natural	40
83	560	68	560	1.2	11.000	5.000	100	12L39	forced	53
83	488	53	488	1.6	12.000	4.000	100	12L20	natural	40
83	488	53	488	1.6	12.000	4.000	100	12L20	natural	40
83	413	65	413	1.3	12.000	4.000	100	12L17	forced	53
83	400	16	400	5.1	2.100	7.000	100	09F60	natural	40
83	400	21	400	4.0	2.500	7.000	100	09H60	natural	40
83	400	21	400	4.0	2.100	7.000	100	09F38	natural	40
83	400	24	400	3.4	3.400	7.000	100	09L51	natural	40
83	400	26	400	3.2	2.500	7.000	100	09H41	natural	40
83	400	29	400	2.9	4.700	7.000	100	12D41	natural	40
83	400	30	400	2.7	3.400	7.000	100	09L41	natural	40
83	400	40	400	2.0	4.700	7.000	100	12D35	forced	53
83	400	50	400	1.6	9.500	7.000	100	14D36	natural	40
83	400	52	400	1.6	8.000	7.000	100	12H35	natural	40
83	400	54	400	1.5	8.000	7.000	100	12H30	natural	40
83	400	71	400	1.2	9.500	7.000	100	14D30	forced	53
83	400	71	400	1.2	8.000	7.000	100	12H34	forced	53
83	400	75	400	1.1	11.000	7.000	100	12L41	natural	40
83	390	26	390	3.2	4.900	5.000	100	12D20	natural	40
83	390	26	390	3.2	4.900	5.000	100	12D20	natural	40
83	390	67	390	1.3	11.000	5.000	100	12L20	natural	40
83	390	67	390	1.3	11.000	5.000	100	12L20	natural	40
83	375	36	375	2.3	9.800	4.000	100	14D15	natural	40
83	375	40	375	2.1	8.300	4.000	100	12H15	natural	40
83	375	40	375	2.1	8.300	4.000	100	12H15	natural	40
83	338	47	338	1.8	9.800	4.000	100	14D14	forced	53
83	338	47	338	1.8	8.300	4.000	100	12H14	forced	53
83	330	34	330	2.5	4.900	5.000	100	12D17	forced	53
83	330	81	330	1.0	11.000	5.000	100	12L17	forced	53
83	300	45	300	1.9	9.700	5.000	100	14D15	natural	40
83	300	49	300	1.7	8.200	5.000	100	12H15	natural	40
83	300	49	300	1.7	8.200	5.000	100	12H15	natural	40

6.2.4

MPG planetary geared motors

Technical data



Selection tables

1-stage gearboxes

Inverter operation						i	Product		Cooling	
M _{2, max} [Nm]	n _{2, th} [r/min]	M ₂ [Nm]	n _{2, eto} [r/min]	c	J [kgcm ²]		MPG	MCS		
83	279	37	279	2.3	4.700	7.000	100	12D20	natural	40
83	279	37	279	2.3	4.700	7.000	100	12D20	natural	40
83	270	58	270	1.4	9.700	5.000	100	14D14	forced	53
83	270	58	270	1.4	8.200	5.000	100	12H14	forced	53
83	236	47	236	1.8	4.700	7.000	100	12D17	forced	53
83	214	63	214	1.3	9.500	7.000	100	14D15	natural	40
83	214	69	214	1.2	8.000	7.000	100	12H15	natural	40
83	214	69	214	1.2	8.000	7.000	100	12H15	natural	40
83	193	82	193	1.0	9.500	7.000	100	14D14	forced	53
83	193	82	193	1.0	8.000	7.000	100	12H14	forced	53
86	330	34	330	5.8	6.900	5.000	200	12D17	forced	54
113	625	41	625	4.9	11.000	4.000	200	12H34	forced	54
113	625	41	625	4.9	12.000	4.000	200	14D30	forced	54
113	375	36	375	5.6	12.000	4.000	200	14D15	natural	44
113	375	40	375	5.1	11.000	4.000	200	12H15	natural	44
113	375	40	375	5.1	11.000	4.000	200	12H15	natural	44
113	338	47	338	4.3	12.000	4.000	200	14D14	forced	54
113	338	47	338	4.3	11.000	4.000	200	12H14	forced	54
120	400	40	400	4.7	6.500	7.000	200	12D35	forced	54
120	236	47	236	4.0	6.500	7.000	200	12D17	forced	54
122	279	37	279	5.2	6.500	7.000	200	12D20	natural	44
122	279	37	279	5.2	6.500	7.000	200	12D20	natural	44
135	280	41	280	3.3	6.300	10.000	200	12D41	natural	44
135	280	58	280	2.3	6.300	10.000	200	12D35	forced	54
135	280	72	280	1.9	11.000	10.000	200	14D36	natural	44
135	280	74	280	1.8	9.600	10.000	200	12H35	natural	44
135	280	77	280	1.8	9.600	10.000	200	12H30	natural	44
135	280	102	280	1.3	9.600	10.000	200	12H34	forced	54
135	280	102	280	1.3	11.000	10.000	200	14D30	forced	54
135	280	107	280	1.3	13.000	10.000	200	12L41	natural	44
135	280	135	280	1.0	17.000	10.000	200	14H32	natural	44
135	195	52	195	2.6	6.300	10.000	200	12D20	natural	44
135	195	52	195	2.6	6.300	10.000	200	12D20	natural	44
135	195	133	195	1.0	13.000	10.000	200	12L20	natural	44
135	195	133	195	1.0	13.000	10.000	200	12L20	natural	44
135	165	67	165	2.0	6.300	10.000	200	12D17	forced	54
135	150	90	150	1.5	11.000	10.000	200	14D15	natural	44
135	150	99	150	1.4	9.600	10.000	200	12H15	natural	44
135	150	99	150	1.4	9.600	10.000	200	12H15	natural	44
135	135	117	135	1.2	11.000	10.000	200	14D14	forced	54

6.2.4

MPG planetary geared motors

Technical data



Selection tables

1-stage gearboxes

Inverter operation						i	Product		Cooling	
M _{2, max} [Nm]	n _{2, th} [r/min]	M ₂ [Nm]	n _{2, eto} [r/min]	c	J [kgcm ²]		MPG	MCS		
135	135	117	135	1.2	9.600	10.000	200	12H14	forced	54
141	500	36	500	5.4	12.000	5.000	200	14D36	natural	44
141	500	37	500	5.3	10.000	5.000	200	12H35	natural	44
141	500	39	500	5.0	10.000	5.000	200	12H30	natural	44
141	500	51	500	3.8	10.000	5.000	200	12H34	forced	54
141	500	51	500	3.8	12.000	5.000	200	14D30	forced	54
141	300	45	300	4.4	12.000	5.000	200	14D15	natural	44
141	300	49	300	4.0	10.000	5.000	200	12H15	natural	44
141	300	49	300	4.0	10.000	5.000	200	12H15	natural	44
141	270	58	270	3.3	12.000	5.000	200	14D14	forced	54
141	270	58	270	3.3	10.000	5.000	200	12H14	forced	54
190	400	50	400	3.8	11.000	7.000	200	14D36	natural	44
190	400	52	400	3.7	9.800	7.000	200	12H35	natural	44
190	400	54	400	3.5	9.800	7.000	200	12H30	natural	44
190	400	71	400	2.7	9.800	7.000	200	12H34	forced	54
190	400	71	400	2.7	11.000	7.000	200	14D30	forced	54
190	400	75	400	2.5	13.000	7.000	200	12L41	natural	44
190	400	94	400	2.0	17.000	7.000	200	14H32	natural	44
190	400	95	400	2.0	13.000	7.000	200	12L39	forced	54
190	400	117	400	1.6	26.000	7.000	200	14L32	natural	44
190	400	143	400	1.3	38.000	7.000	200	14P32	natural	44
190	400	143	400	1.3	70.000	7.000	200	19F30	natural	44
190	400	173	400	1.1	26.000	7.000	200	14L30	forced	54
190	396	140	396	1.4	17.000	7.000	200	14H28	forced	54
190	279	93	279	2.0	13.000	7.000	200	12L20	natural	44
190	279	93	279	2.0	13.000	7.000	200	12L20	natural	44
190	236	114	236	1.7	13.000	7.000	200	12L17	forced	54
190	214	63	214	3.0	11.000	7.000	200	14D15	natural	44
190	214	69	214	2.8	9.800	7.000	200	12H15	natural	44
190	214	69	214	2.8	9.800	7.000	200	12H15	natural	44
190	214	108	214	1.8	17.000	7.000	200	14H15	natural	44
190	214	156	214	1.2	26.000	7.000	200	14L15	natural	44
190	204	182	204	1.0	70.000	7.000	200	19F14	natural	44
190	193	82	193	2.3	11.000	7.000	200	14D14	forced	54
190	193	82	193	2.3	9.800	7.000	200	12H14	forced	54
190	171	162	171	1.2	17.000	7.000	200	14H12	forced	54
195	500	54	500	3.6	14.000	5.000	200	12L41	natural	44
195	500	67	500	2.9	18.000	5.000	200	14H32	natural	44
195	500	68	500	2.9	14.000	5.000	200	12L39	forced	54
195	500	83	500	2.3	27.000	5.000	200	14L32	natural	44

6.2.4

MPG planetary geared motors

Technical data



Selection tables

1-stage gearboxes

Inverter operation						i	Product		Cooling	
M _{2, max} [Nm]	n _{2, th} [r/min]	M ₂ [Nm]	n _{2, eto} [r/min]	c	J [kgcm ²]		MPG	MCS		
195	500	100	500	1.9	18.000	5.000	200	14H28	forced	54
195	500	102	500	1.9	38.000	5.000	200	14P32	natural	44
195	500	102	500	1.9	70.000	5.000	200	19F30	natural	44
195	500	124	500	1.6	27.000	5.000	200	14L30	forced	54
195	500	140	500	1.4	110.000	5.000	200	19J30	natural	44
195	500	158	500	1.2	70.000	5.000	200	19F29	forced	54
195	500	161	500	1.2	38.000	5.000	200	14P26	forced	54
195	390	67	390	2.9	14.000	5.000	200	12L20	natural	44
195	390	67	390	2.9	14.000	5.000	200	12L20	natural	44
195	330	81	330	2.4	14.000	5.000	200	12L17	forced	54
195	300	77	300	2.5	18.000	5.000	200	14H15	natural	44
195	300	111	300	1.8	27.000	5.000	200	14L15	natural	44
195	285	130	285	1.5	70.000	5.000	200	19F14	natural	44
195	270	144	270	1.4	38.000	5.000	200	14P14	natural	44
195	270	148	270	1.3	27.000	5.000	200	14L14	forced	54
195	240	116	240	1.7	18.000	5.000	200	14H12	forced	54
195	240	185	240	1.1	70.000	5.000	200	19F12	forced	54
197	329	71	329	5.3	16.000	7.000	300	14D30	forced	57
197	193	82	193	4.7	16.000	7.000	300	14D14	forced	57
200	625	43	625	4.7	14.000	4.000	200	12L41	natural	44
200	625	54	625	3.7	14.000	4.000	200	12L39	forced	54
200	625	54	625	3.7	18.000	4.000	200	14H32	natural	44
200	625	67	625	3.0	27.000	4.000	200	14L32	natural	44
200	625	80	625	2.5	18.000	4.000	200	14H28	forced	54
200	625	82	625	2.5	39.000	4.000	200	14P32	natural	44
200	625	82	625	2.5	71.000	4.000	200	19F30	natural	44
200	625	99	625	2.0	27.000	4.000	200	14L30	forced	54
200	625	112	625	1.8	111.000	4.000	200	19J30	natural	44
200	625	126	625	1.6	71.000	4.000	200	19F29	forced	54
200	625	128	625	1.6	39.000	4.000	200	14P26	forced	54
200	488	53	488	3.8	14.000	4.000	200	12L20	natural	44
200	488	53	488	3.8	14.000	4.000	200	12L20	natural	44
200	413	65	413	3.1	14.000	4.000	200	12L17	forced	54
200	375	62	375	3.2	18.000	4.000	200	14H15	natural	44
200	375	89	375	2.3	27.000	4.000	200	14L15	natural	44
200	356	104	356	1.9	71.000	4.000	200	19F14	natural	44
200	356	156	356	1.3	111.000	4.000	200	19J14	natural	44
200	338	115	338	1.7	39.000	4.000	200	14P14	natural	44
200	338	118	338	1.7	27.000	4.000	200	14L14	forced	54
200	300	93	300	2.2	18.000	4.000	200	14H12	forced	54

6.2.4

MPG planetary geared motors

Technical data



Selection tables

1-stage gearboxes

Inverter operation						i	Product		Cooling	
M _{2, max} [Nm]	n _{2, th} [r/min]	M ₂ [Nm]	n _{2, eto} [r/min]	c	J [kgcm ²]		MPG	MCS		
200	300	148	300	1.4	71.000	4.000	200	19F12	forced	54
200	263	162	263	1.2	39.000	4.000	200	14P11	forced	54
213	525	80	525	4.9	25.000	4.000	300	14H28	forced	57
213	300	93	300	4.2	25.000	4.000	300	14H12	forced	57
245	260	72	260	3.4	15.000	10.000	300	14D36	natural	48
245	260	102	260	2.4	15.000	10.000	300	14D30	forced	57
245	260	135	260	1.8	21.000	10.000	300	14H32	natural	48
245	260	167	260	1.5	30.000	10.000	300	14L32	natural	48
245	260	200	260	1.2	21.000	10.000	300	14H28	forced	57
245	260	204	260	1.2	41.000	10.000	300	14P32	natural	48
245	260	204	260	1.2	73.000	10.000	300	19F30	natural	48
245	150	90	150	2.7	15.000	10.000	300	14D15	natural	48
245	150	154	150	1.6	21.000	10.000	300	14H15	natural	48
245	150	222	150	1.1	30.000	10.000	300	14L15	natural	48
245	135	117	135	2.1	15.000	10.000	300	14D14	forced	57
245	120	232	120	1.1	21.000	10.000	300	14H12	forced	57
266	420	100	420	3.9	23.000	5.000	300	14H28	forced	57
266	240	116	240	3.4	23.000	5.000	300	14H12	forced	57
267	420	67	420	5.8	23.000	5.000	300	14H32	natural	48
267	300	77	300	5.0	23.000	5.000	300	14H15	natural	48
299	525	67	525	5.8	34.000	4.000	300	14L32	natural	48
299	525	99	525	4.0	34.000	4.000	300	14L30	forced	57
299	375	89	375	4.4	34.000	4.000	300	14L15	natural	48
299	338	118	338	3.3	34.000	4.000	300	14L14	forced	57
334	525	82	525	4.8	76.000	4.000	300	19F30	natural	48
334	525	126	525	3.1	76.000	4.000	300	19F29	forced	57
334	356	104	356	3.8	76.000	4.000	300	19F14	natural	48
334	300	148	300	2.6	76.000	4.000	300	19F12	forced	57
372	329	140	329	2.7	22.000	7.000	300	14H28	forced	57
372	171	162	171	2.3	22.000	7.000	300	14H12	forced	57
373	420	83	420	4.7	32.000	5.000	300	14L32	natural	48
373	329	94	329	4.0	22.000	7.000	300	14H32	natural	48
373	300	111	300	3.5	32.000	5.000	300	14L15	natural	48
373	214	108	214	3.5	22.000	7.000	300	14H15	natural	48
374	420	124	420	3.2	32.000	5.000	300	14L30	forced	57
374	270	148	270	2.6	32.000	5.000	300	14L14	forced	57
380	329	117	329	3.3	31.000	7.000	300	14L32	natural	48
380	329	143	329	2.7	42.000	7.000	300	14P32	natural	48
380	329	143	329	2.7	74.000	7.000	300	19F30	natural	48
380	329	173	329	2.2	31.000	7.000	300	14L30	forced	57

6.2.4

MPG planetary geared motors

Technical data



Selection tables

1-stage gearboxes

Inverter operation						i	Product		Cooling	
M _{2, max} [Nm]	n _{2, th} [r/min]	M ₂ [Nm]	n _{2, eto} [r/min]	c	J [kgcm ²]		MPG	MCS		
380	329	197	329	1.9	114.000	7.000	300	19J30	natural	48
380	329	216	329	1.8	169.000	7.000	300	19P30	natural	48
380	329	221	329	1.7	74.000	7.000	300	19F29	forced	57
380	329	225	329	1.7	42.000	7.000	300	14P26	forced	57
380	329	344	329	1.1	114.000	7.000	300	19J29	forced	57
380	329	359	329	1.1	169.000	7.000	300	19P29	forced	57
380	214	156	214	2.4	31.000	7.000	300	14L15	natural	48
380	204	182	204	2.1	74.000	7.000	300	19F14	natural	48
380	204	273	204	1.4	114.000	7.000	300	19J14	natural	48
380	193	202	193	1.9	42.000	7.000	300	14P14	natural	48
380	193	207	193	1.8	31.000	7.000	300	14L14	forced	57
380	193	346	193	1.1	169.000	7.000	300	19P14	natural	48
380	171	259	171	1.5	74.000	7.000	300	19F12	forced	57
380	150	284	150	1.3	42.000	7.000	300	14P11	forced	57
390	525	82	525	4.8	46.000	4.000	300	14P32	natural	48
390	525	112	525	3.5	116.000	4.000	300	19J30	natural	48
390	525	124	525	3.2	171.000	4.000	300	19P30	natural	48
390	525	128	525	3.0	46.000	4.000	300	14P26	forced	57
390	525	196	525	2.0	116.000	4.000	300	19J29	forced	57
390	525	205	525	1.9	171.000	4.000	300	19P29	forced	57
390	420	102	420	3.8	44.000	5.000	300	14P32	natural	48
390	420	102	420	3.8	76.000	5.000	300	19F30	natural	48
390	420	140	420	2.8	116.000	5.000	300	19J30	natural	48
390	420	154	420	2.5	171.000	5.000	300	19P30	natural	48
390	420	158	420	2.5	76.000	5.000	300	19F29	forced	57
390	420	161	420	2.4	44.000	5.000	300	14P26	forced	57
390	420	245	420	1.6	116.000	5.000	300	19J29	forced	57
390	420	257	420	1.5	171.000	5.000	300	19P29	forced	57
390	356	156	356	2.5	116.000	4.000	300	19J14	natural	48
390	338	115	338	3.4	46.000	4.000	300	14P14	natural	48
390	338	198	338	2.0	171.000	4.000	300	19P14	natural	48
390	300	244	300	1.6	116.000	4.000	300	19J12	forced	57
390	300	278	300	1.4	171.000	4.000	300	19P12	forced	57
390	285	130	285	3.0	76.000	5.000	300	19F14	natural	48
390	285	195	285	2.0	116.000	5.000	300	19J14	natural	48
390	270	144	270	2.7	44.000	5.000	300	14P14	natural	48
390	270	247	270	1.6	171.000	5.000	300	19P14	natural	48
390	263	162	263	2.4	46.000	4.000	300	14P11	forced	57
390	240	185	240	2.1	76.000	5.000	300	19F12	forced	57
390	240	305	240	1.3	116.000	5.000	300	19J12	forced	57

6.2.4

MPG planetary geared motors

Technical data



Selection tables

1-stage gearboxes

Inverter operation						i	Product		Cooling	
M _{2, max} [Nm]	n _{2, th} [r/min]	M ₂ [Nm]	n _{2, eto} [r/min]	c	J [kgcm ²]		MPG	MCS		
390	240	347	240	1.1	171.000	5.000	300	19P12	forced	57
390	210	203	210	1.9	44.000	5.000	300	14P11	forced	57

MPG planetary geared motors



Technical data

Selection tables

2-stage gearboxes

Inverter operation						i	Product		Cooling	
M _{2, max} [Nm]	n _{2, th} [r/min]	M ₂ [Nm]	n _{2, eto} [r/min]	c	J [kgcm ²]		MPG	MCS		
29	275	7	275	3.9	0.300	16.000	050	06C60	natural	39
29	275	14	275	2.1	0.400	16.000	050	06F60	natural	39
29	275	18	275	1.6	0.500	16.000	050	06I60	natural	39
29	275	27	275	1.1	1.300	16.000	050	09D60	natural	39
29	253	9	253	3.2	0.300	16.000	050	06C41	natural	39
29	253	9	253	3.2	0.300	16.000	050	06C41	natural	39
29	253	18	253	1.6	0.400	16.000	050	06F41	natural	39
29	253	18	253	1.6	0.400	16.000	050	06F41	natural	39
29	253	23	253	1.3	0.500	16.000	050	06I41	natural	39
29	253	23	253	1.3	0.500	16.000	050	06I41	natural	39
29	220	9	220	3.1	0.300	20.000	050	06C60	natural	39
29	220	17	220	1.7	0.400	20.000	050	06F60	natural	39
29	220	23	220	1.3	0.500	20.000	050	06I60	natural	39
29	203	11	203	2.6	0.300	20.000	050	06C41	natural	39
29	203	11	203	2.6	0.300	20.000	050	06C41	natural	39
29	203	23	203	1.3	0.400	20.000	050	06F41	natural	39
29	203	23	203	1.3	0.400	20.000	050	06F41	natural	39
29	203	29	203	1.0	0.500	20.000	050	06I41	natural	39
29	203	29	203	1.0	0.500	20.000	050	06I41	natural	39
29	176	12	176	2.5	0.300	25.000	050	06C60	natural	39
29	176	22	176	1.4	0.400	25.000	050	06F60	natural	39
29	176	28	176	1.0	0.500	25.000	050	06I60	natural	39
29	162	14	162	2.1	0.300	25.000	050	06C41	natural	39
29	162	14	162	2.1	0.300	25.000	050	06C41	natural	39
29	162	29	162	1.0	0.400	25.000	050	06F41	natural	39
29	162	29	162	1.0	0.400	25.000	050	06F41	natural	39
29	157	13	157	2.2	0.300	28.000	050	06C60	natural	39
29	157	24	157	1.2	0.400	28.000	050	06F60	natural	39
29	145	16	145	1.9	0.300	28.000	050	06C41	natural	39
29	145	16	145	1.9	0.300	28.000	050	06C41	natural	39
29	126	16	126	1.8	0.300	35.000	050	06C60	natural	39
29	116	20	116	1.5	0.300	35.000	050	06C41	natural	39
29	116	20	116	1.5	0.300	35.000	050	06C41	natural	39
29	110	19	110	1.6	0.300	40.000	050	06C60	natural	39
29	101	22	101	1.3	0.300	40.000	050	06C41	natural	39
29	101	22	101	1.3	0.300	40.000	050	06C41	natural	39
29	96	23	96	1.2	0.300	50.000	050	06C60	natural	39
29	81	28	81	1.0	0.300	50.000	050	06C41	natural	39
29	81	28	81	1.0	0.300	50.000	050	06C41	natural	39
57	140	14	140	5.9	0.300	25.000	100	06C41	natural	42

6.2.4

MPG planetary geared motors

Technical data



Selection tables

2-stage gearboxes

Inverter operation						i	Product		Cooling	
M _{2, max} [Nm]	n _{2, th} [r/min]	M ₂ [Nm]	n _{2, eto} [r/min]	c	J [kgcm ²]		MPG	MCS		
57	140	14	140	5.9	0.300	25.000	100	06C41	natural	42
58	45	47	45	1.2	0.300	100.000	100	06C60	natural	42
58	41	56	41	1.0	0.300	100.000	100	06C41	natural	42
58	41	56	41	1.0	0.300	100.000	100	06C41	natural	42
64	125	16	125	5.3	0.300	28.000	100	06C41	natural	42
64	125	16	125	5.3	0.300	28.000	100	06C41	natural	42
67	219	18	219	4.5	0.500	16.000	100	06F41	natural	42
67	219	18	219	4.5	0.500	16.000	100	06F41	natural	42
76	88	19	88	4.0	0.300	40.000	100	06C60	natural	42
76	88	22	88	3.4	0.300	40.000	100	06C41	natural	42
76	88	22	88	3.4	0.300	40.000	100	06C41	natural	42
76	88	34	88	2.2	0.400	40.000	100	06F60	natural	42
76	88	45	88	1.7	0.500	40.000	100	06I60	natural	42
76	88	46	88	1.7	0.400	40.000	100	06F41	natural	42
76	88	46	88	1.7	0.400	40.000	100	06F41	natural	42
76	88	57	88	1.3	0.500	40.000	100	06I41	natural	42
76	88	67	88	1.1	1.300	40.000	100	09D60	natural	42
80	100	16	100	5.1	0.300	35.000	100	06C60	natural	42
80	100	20	100	4.2	0.300	35.000	100	06C41	natural	42
80	100	20	100	4.2	0.300	35.000	100	06C41	natural	42
83	219	18	219	4.6	0.500	16.000	100	06I60	natural	42
83	219	23	219	3.6	0.500	16.000	100	06I41	natural	42
83	219	27	219	3.1	1.400	16.000	100	09D60	natural	42
83	219	36	219	2.3	1.800	16.000	100	09F60	natural	42
83	219	36	219	2.3	1.400	16.000	100	09D41	natural	42
83	219	46	219	1.8	2.200	16.000	100	09H60	natural	42
83	219	46	219	1.8	1.800	16.000	100	09F38	natural	42
83	219	54	219	1.5	3.100	16.000	100	09L51	natural	42
83	219	57	219	1.4	2.200	16.000	100	09H41	natural	42
83	219	68	219	1.2	3.100	16.000	100	09L41	natural	42
83	175	17	175	4.8	0.400	20.000	100	06F60	natural	42
83	175	23	175	3.6	0.400	20.000	100	06F41	natural	42
83	175	23	175	3.6	0.400	20.000	100	06F41	natural	42
83	175	23	175	3.7	0.500	20.000	100	06I60	natural	42
83	175	29	175	2.9	0.500	20.000	100	06I41	natural	42
83	175	33	175	2.5	1.300	20.000	100	09D60	natural	42
83	175	45	175	1.8	1.700	20.000	100	09F60	natural	42
83	175	45	175	1.9	1.300	20.000	100	09D41	natural	42
83	175	57	175	1.4	2.100	20.000	100	09H60	natural	42
83	175	58	175	1.4	1.700	20.000	100	09F38	natural	42

6.2.4

MPG planetary geared motors



Technical data

Selection tables

2-stage gearboxes

Inverter operation						i	Product		Cooling	
M _{2, max} [Nm]	n _{2, th} [r/min]	M ₂ [Nm]	n _{2, eto} [r/min]	c	J [kgcm ²]		MPG	MCS		
83	175	68	175	1.2	3.000	20.000	100	09L51	natural	42
83	175	72	175	1.2	2.100	20.000	100	09H41	natural	42
83	140	22	140	3.9	0.400	25.000	100	06F60	natural	42
83	140	28	140	2.9	0.500	25.000	100	06I60	natural	42
83	140	29	140	2.9	0.400	25.000	100	06F41	natural	42
83	140	29	140	2.9	0.400	25.000	100	06F41	natural	42
83	140	36	140	2.3	0.500	25.000	100	06I41	natural	42
83	140	42	140	2.0	1.300	25.000	100	09D60	natural	42
83	140	56	140	1.5	1.300	25.000	100	09D41	natural	42
83	140	57	140	1.5	1.700	25.000	100	09F60	natural	42
83	140	72	140	1.2	2.100	25.000	100	09H60	natural	42
83	140	73	140	1.1	1.700	25.000	100	09F38	natural	42
83	125	24	125	3.4	0.400	28.000	100	06F60	natural	42
83	125	32	125	2.6	0.400	28.000	100	06F41	natural	42
83	125	32	125	2.6	0.400	28.000	100	06F41	natural	42
83	125	32	125	2.6	0.500	28.000	100	06I60	natural	42
83	125	40	125	2.1	0.500	28.000	100	06I41	natural	42
83	125	47	125	1.8	1.300	28.000	100	09D60	natural	42
83	125	63	125	1.3	1.300	28.000	100	09D41	natural	42
83	125	64	125	1.3	1.700	28.000	100	09F60	natural	42
83	125	80	125	1.0	2.100	28.000	100	09H60	natural	42
83	125	81	125	1.0	1.700	28.000	100	09F38	natural	42
83	100	30	100	2.8	0.400	35.000	100	06F60	natural	42
83	100	40	100	2.1	0.400	35.000	100	06F41	natural	42
83	100	40	100	2.1	0.400	35.000	100	06F41	natural	42
83	100	40	100	2.1	0.500	35.000	100	06I60	natural	42
83	100	50	100	1.6	0.500	35.000	100	06I41	natural	42
83	100	58	100	1.4	1.300	35.000	100	09D60	natural	42
83	100	78	100	1.1	1.300	35.000	100	09D41	natural	42
83	100	79	100	1.1	1.700	35.000	100	09F60	natural	42
83	76	23	76	3.5	0.300	50.000	100	06C60	natural	42
83	76	28	76	3.0	0.300	50.000	100	06C41	natural	42
83	76	28	76	3.0	0.300	50.000	100	06C41	natural	42
83	76	43	76	1.9	0.400	50.000	100	06F60	natural	42
83	76	57	76	1.4	0.400	50.000	100	06F41	natural	42
83	76	57	76	1.4	0.400	50.000	100	06F41	natural	42
83	76	57	76	1.5	0.500	50.000	100	06I60	natural	42
83	76	72	76	1.2	0.500	50.000	100	06I41	natural	42
83	64	33	64	2.5	0.300	70.000	100	06C60	natural	42
83	64	60	64	1.4	0.400	70.000	100	06F60	natural	42

6.2.4

MPG planetary geared motors



Technical data

Selection tables

2-stage gearboxes

Inverter operation						i	Product		Cooling	
M _{2, max} [Nm]	n _{2, th} [r/min]	M ₂ [Nm]	n _{2, eto} [r/min]	c	J [kgcm ²]		MPG	MCS		
83	64	79	64	1.1	0.500	70.000	100	06I60	natural	42
83	58	39	58	2.1	0.300	70.000	100	06C41	natural	42
83	58	39	58	2.1	0.300	70.000	100	06C41	natural	42
83	58	80	58	1.0	0.400	70.000	100	06F41	natural	42
83	58	80	58	1.0	0.400	70.000	100	06F41	natural	42
144	194	36	194	5.6	1.900	16.000	200	09D41	natural	46
144	194	36	194	5.6	1.900	16.000	200	09D41	natural	46
181	155	33	155	5.9	1.700	20.000	200	09D60	natural	46
181	155	45	155	4.3	1.700	20.000	200	09D41	natural	46
181	155	45	155	4.3	1.700	20.000	200	09D41	natural	46
190	60	116	60	1.6	1.600	70.000	200	09D60	natural	46
190	60	159	60	1.2	2.000	70.000	200	09F60	natural	46
190	58	157	58	1.2	1.600	70.000	200	09D41	natural	46
190	58	157	58	1.2	1.600	70.000	200	09D41	natural	46
195	155	45	155	4.3	2.100	20.000	200	09F60	natural	46
195	155	57	155	3.4	2.500	20.000	200	09H60	natural	46
195	155	58	155	3.4	2.100	20.000	200	09F38	natural	46
195	155	68	155	2.9	3.400	20.000	200	09L51	natural	46
195	155	72	155	2.7	2.500	20.000	200	09H41	natural	46
195	155	81	155	2.4	4.800	20.000	200	12D41	natural	46
195	155	85	155	2.3	3.400	20.000	200	09L41	natural	46
195	155	113	155	1.7	4.800	20.000	200	12D35	forced	56
195	155	144	155	1.4	8.100	20.000	200	12H35	natural	46
195	150	151	150	1.3	8.100	20.000	200	12H30	natural	46
195	124	42	124	4.7	1.700	25.000	200	09D60	natural	46
195	124	56	124	3.5	1.700	25.000	200	09D41	natural	46
195	124	56	124	3.5	1.700	25.000	200	09D41	natural	46
195	124	57	124	3.4	2.100	25.000	200	09F60	natural	46
195	124	72	124	2.7	2.500	25.000	200	09H60	natural	46
195	124	73	124	2.7	2.100	25.000	200	09F38	natural	46
195	124	84	124	2.3	3.400	25.000	200	09L51	natural	46
195	124	90	124	2.2	2.500	25.000	200	09H41	natural	46
195	124	101	124	1.9	4.800	25.000	200	12D41	natural	46
195	124	106	124	1.8	3.400	25.000	200	09L41	natural	46
195	124	142	124	1.4	4.800	25.000	200	12D35	forced	56
195	124	180	124	1.1	8.100	25.000	200	12H35	natural	46
195	120	189	120	1.0	8.100	25.000	200	12H30	natural	46
195	98	102	98	1.9	4.800	20.000	200	12D20	natural	46
195	98	102	98	1.9	4.800	20.000	200	12D20	natural	46
195	89	58	89	3.4	1.600	35.000	200	09D60	natural	46

6.2.4

MPG planetary geared motors

Technical data



Selection tables

2-stage gearboxes

Inverter operation						i	Product		Cooling	
M _{2, max} [Nm]	n _{2, th} [r/min]	M ₂ [Nm]	n _{2, eto} [r/min]	c	J [kgcm ²]		MPG	MCS		
195	89	78	89	2.5	1.600	35.000	200	09D41	natural	46
195	89	78	89	2.5	1.600	35.000	200	09D41	natural	46
195	89	79	89	2.5	2.000	35.000	200	09F60	natural	46
195	89	101	89	1.9	2.400	35.000	200	09H60	natural	46
195	89	102	89	1.9	2.000	35.000	200	09F38	natural	46
195	89	118	89	1.6	3.300	35.000	200	09L51	natural	46
195	89	125	89	1.6	2.400	35.000	200	09H41	natural	46
195	89	141	89	1.4	4.700	35.000	200	12D41	natural	46
195	89	149	89	1.3	3.300	35.000	200	09L41	natural	46
195	83	132	83	1.5	4.800	20.000	200	12D17	forced	56
195	78	128	78	1.5	4.800	25.000	200	12D20	natural	46
195	78	128	78	1.5	4.800	25.000	200	12D20	natural	46
195	75	194	75	1.0	8.100	20.000	200	12H15	natural	46
195	75	194	75	1.0	8.100	20.000	200	12H15	natural	46
195	70	83	70	2.3	1.600	50.000	200	09D60	natural	46
195	70	112	70	1.7	1.600	50.000	200	09D41	natural	46
195	70	112	70	1.7	1.600	50.000	200	09D41	natural	46
195	70	113	70	1.7	2.000	50.000	200	09F60	natural	46
195	70	144	70	1.4	2.400	50.000	200	09H60	natural	46
195	70	145	70	1.3	2.000	50.000	200	09F38	natural	46
195	70	169	70	1.1	3.300	50.000	200	09L51	natural	46
195	70	179	70	1.1	2.400	50.000	200	09H41	natural	46
195	66	165	66	1.2	4.800	25.000	200	12D17	forced	56
195	56	179	56	1.1	4.700	35.000	200	12D20	natural	46
195	56	179	56	1.1	4.700	35.000	200	12D20	natural	46
200	194	36	194	5.5	2.300	16.000	200	09F60	natural	46
200	194	46	194	4.3	2.700	16.000	200	09H60	natural	46
200	194	46	194	4.3	2.300	16.000	200	09F38	natural	46
200	194	54	194	3.7	3.600	16.000	200	09L51	natural	46
200	194	57	194	3.5	2.700	16.000	200	09H41	natural	46
200	194	65	194	3.1	4.900	16.000	200	12D41	natural	46
200	194	68	194	2.9	3.600	16.000	200	09L41	natural	46
200	194	91	194	2.2	4.900	16.000	200	12D35	forced	56
200	194	115	194	1.7	8.200	16.000	200	12H35	natural	46
200	194	159	194	1.3	8.200	16.000	200	12H34	forced	56
200	194	168	194	1.2	12.000	16.000	200	12L41	natural	46
200	188	121	188	1.6	8.200	16.000	200	12H30	natural	46
200	122	82	122	2.4	4.900	16.000	200	12D20	natural	46
200	122	82	122	2.4	4.900	16.000	200	12D20	natural	46
200	111	47	111	4.3	1.600	28.000	200	09D60	natural	46

6.2.4

MPG planetary geared motors

Technical data



Selection tables

2-stage gearboxes

Inverter operation						i	Product		Cooling	
M _{2, max} [Nm]	n _{2, th} [r/min]	M ₂ [Nm]	n _{2, eto} [r/min]	c	J [kgcm ²]		MPG	MCS		
200	111	63	111	3.2	1.600	28.000	200	09D41	natural	46
200	111	63	111	3.2	1.600	28.000	200	09D41	natural	46
200	111	64	111	3.1	2.000	28.000	200	09F60	natural	46
200	111	80	111	2.5	2.400	28.000	200	09H60	natural	46
200	111	81	111	2.5	2.000	28.000	200	09F38	natural	46
200	111	95	111	2.1	3.300	28.000	200	09L51	natural	46
200	111	100	111	2.0	2.400	28.000	200	09H41	natural	46
200	111	113	111	1.8	4.700	28.000	200	12D41	natural	46
200	111	119	111	1.7	3.300	28.000	200	09L41	natural	46
200	111	159	111	1.3	4.700	28.000	200	12D35	forced	56
200	103	106	103	1.9	4.900	16.000	200	12D17	forced	56
200	94	155	94	1.3	8.200	16.000	200	12H15	natural	46
200	94	155	94	1.3	8.200	16.000	200	12H15	natural	46
200	84	183	84	1.1	8.200	16.000	200	12H14	forced	56
200	78	67	78	3.0	1.600	40.000	200	09D60	natural	46
200	78	90	78	2.2	1.600	40.000	200	09D41	natural	46
200	78	90	78	2.2	1.600	40.000	200	09D41	natural	46
200	78	91	78	2.2	2.000	40.000	200	09F60	natural	46
200	78	115	78	1.7	2.400	40.000	200	09H60	natural	46
200	78	116	78	1.7	2.000	40.000	200	09F38	natural	46
200	78	135	78	1.5	3.300	40.000	200	09L51	natural	46
200	78	143	78	1.4	2.400	40.000	200	09H41	natural	46
200	78	161	78	1.2	4.600	40.000	200	12D41	natural	46
200	78	170	78	1.2	3.300	40.000	200	09L41	natural	46
200	70	143	70	1.4	4.700	28.000	200	12D20	natural	46
200	70	143	70	1.4	4.700	28.000	200	12D20	natural	46
200	59	185	59	1.1	4.700	28.000	200	12D17	forced	56
269	181	91	181	4.3	7.200	16.000	300	12D35	forced	59
269	103	106	103	3.7	7.200	16.000	300	12D17	forced	59
274	122	82	122	4.8	7.200	16.000	300	12D20	natural	50
274	122	82	122	4.8	7.200	16.000	300	12D20	natural	50
336	145	113	145	3.4	6.800	20.000	300	12D35	forced	59
336	83	132	83	3.0	6.800	20.000	300	12D17	forced	59
342	145	81	145	4.8	6.800	20.000	300	12D41	natural	50
342	98	102	98	3.8	6.800	20.000	300	12D20	natural	50
342	98	102	98	3.8	6.800	20.000	300	12D20	natural	50
380	46	282	46	1.4	6.200	70.000	300	12D41	natural	50
380	28	358	28	1.1	6.200	70.000	300	12D20	natural	50
380	28	358	28	1.1	6.200	70.000	300	12D20	natural	50
390	181	113	181	3.5	12.000	16.000	300	14D36	natural	50

6.2.4

MPG planetary geared motors

Technical data



Selection tables

2-stage gearboxes

Inverter operation						i	Product		Cooling	
M _{2, max} [Nm]	n _{2, th} [r/min]	M ₂ [Nm]	n _{2, eto} [r/min]	c	J [kgcm ²]		MPG	MCS		
390	181	115	181	3.4	10.000	16.000	300	12H35	natural	50
390	181	121	181	3.2	10.000	16.000	300	12H30	natural	50
390	181	159	181	2.5	10.000	16.000	300	12H34	forced	59
390	181	160	181	2.4	12.000	16.000	300	14D30	forced	59
390	181	168	181	2.3	14.000	16.000	300	12L41	natural	50
390	181	212	181	1.8	18.000	16.000	300	14H32	natural	50
390	181	212	181	1.8	14.000	16.000	300	12L39	forced	59
390	181	261	181	1.5	27.000	16.000	300	14L32	natural	50
390	181	319	181	1.2	71.000	16.000	300	19F30	natural	50
390	181	320	181	1.2	38.000	16.000	300	14P32	natural	50
390	181	387	181	1.0	27.000	16.000	300	14L30	forced	59
390	173	314	173	1.2	18.000	16.000	300	14H28	forced	59
390	145	141	145	2.8	11.000	20.000	300	14D36	natural	50
390	145	144	145	2.7	10.000	20.000	300	12H35	natural	50
390	145	151	145	2.6	10.000	20.000	300	12H30	natural	50
390	145	199	145	2.0	10.000	20.000	300	12H34	forced	59
390	145	200	145	1.9	11.000	20.000	300	14D30	forced	59
390	145	211	145	1.9	13.000	20.000	300	12L41	natural	50
390	145	264	145	1.5	17.000	20.000	300	14H32	natural	50
390	145	265	145	1.5	13.000	20.000	300	12L39	forced	59
390	145	326	145	1.2	27.000	20.000	300	14L32	natural	50
390	122	208	122	1.9	14.000	16.000	300	12L20	natural	50
390	122	208	122	1.9	14.000	16.000	300	12L20	natural	50
390	116	101	116	3.9	6.700	25.000	300	12D41	natural	50
390	116	142	116	2.8	6.700	25.000	300	12D35	forced	59
390	116	176	116	2.2	11.000	25.000	300	14D36	natural	50
390	116	180	116	2.2	10.000	25.000	300	12H35	natural	50
390	116	189	116	2.1	10.000	25.000	300	12H30	natural	50
390	116	249	116	1.6	11.000	25.000	300	14D30	forced	59
390	116	249	116	1.6	10.000	25.000	300	12H34	forced	59
390	116	263	116	1.5	13.000	25.000	300	12L41	natural	50
390	116	331	116	1.2	17.000	25.000	300	14H32	natural	50
390	116	331	116	1.2	13.000	25.000	300	12L39	forced	59
390	104	113	104	3.5	6.400	28.000	300	12D41	natural	50
390	104	159	104	2.5	6.400	28.000	300	12D35	forced	59
390	104	198	104	2.0	11.000	28.000	300	14D36	natural	50
390	104	202	104	1.9	9.700	28.000	300	12H35	natural	50
390	104	212	104	1.8	9.700	28.000	300	12H30	natural	50
390	104	278	104	1.4	9.700	28.000	300	12H34	forced	59
390	104	279	104	1.4	11.000	28.000	300	14D30	forced	59

6.2.4

MPG planetary geared motors



Technical data

Selection tables

2-stage gearboxes

Inverter operation						i	Product		Cooling	
M _{2, max} [Nm]	n _{2, th} [r/min]	M ₂ [Nm]	n _{2, eto} [r/min]	c	J [kgcm ²]		MPG	MCS		
390	104	295	104	1.3	13.000	28.000	300	12L41	natural	50
390	104	370	104	1.1	17.000	28.000	300	14H32	natural	50
390	104	371	104	1.1	13.000	28.000	300	12L39	forced	59
390	103	255	103	1.5	14.000	16.000	300	12L17	forced	59
390	98	261	98	1.5	13.000	20.000	300	12L20	natural	50
390	98	261	98	1.5	13.000	20.000	300	12L20	natural	50
390	94	140	94	2.8	12.000	16.000	300	14D15	natural	50
390	94	155	94	2.5	10.000	16.000	300	12H15	natural	50
390	94	155	94	2.5	10.000	16.000	300	12H15	natural	50
390	94	242	94	1.6	18.000	16.000	300	14H15	natural	50
390	94	348	94	1.1	27.000	16.000	300	14L15	natural	50
390	84	183	84	2.1	10.000	16.000	300	12H14	forced	59
390	84	183	84	2.1	12.000	16.000	300	14D14	forced	59
390	83	141	83	2.8	6.400	35.000	300	12D41	natural	50
390	83	198	83	2.0	6.400	35.000	300	12D35	forced	59
390	83	247	83	1.6	11.000	35.000	300	14D36	natural	50
390	83	252	83	1.6	9.700	35.000	300	12H35	natural	50
390	83	265	83	1.5	9.700	35.000	300	12H30	natural	50
390	83	319	83	1.2	13.000	20.000	300	12L17	forced	59
390	83	348	83	1.1	9.700	35.000	300	12H34	forced	59
390	83	349	83	1.1	11.000	35.000	300	14D30	forced	59
390	83	368	83	1.1	13.000	35.000	300	12L41	natural	50
390	78	128	78	3.0	6.700	25.000	300	12D20	natural	50
390	78	128	78	3.0	6.700	25.000	300	12D20	natural	50
390	78	326	78	1.2	13.000	25.000	300	12L20	natural	50
390	78	326	78	1.2	13.000	25.000	300	12L20	natural	50
390	75	175	75	2.2	11.000	20.000	300	14D15	natural	50
390	75	194	75	2.0	10.000	20.000	300	12H15	natural	50
390	75	194	75	2.0	10.000	20.000	300	12H15	natural	50
390	75	302	75	1.3	17.000	20.000	300	14H15	natural	50
390	75	363	75	1.1	18.000	16.000	300	14H12	forced	59
390	73	161	73	2.4	6.200	40.000	300	12D41	natural	50
390	73	226	73	1.7	6.200	40.000	300	12D35	forced	59
390	73	282	73	1.4	11.000	40.000	300	14D36	natural	50
390	73	288	73	1.4	9.500	40.000	300	12H35	natural	50
390	73	302	73	1.3	9.500	40.000	300	12H30	natural	50
390	70	143	70	2.7	6.400	28.000	300	12D20	natural	50
390	70	143	70	2.7	6.400	28.000	300	12D20	natural	50
390	70	365	70	1.1	13.000	28.000	300	12L20	natural	50
390	70	365	70	1.1	13.000	28.000	300	12L20	natural	50

6.2.4

MPG planetary geared motors

Technical data



Selection tables

2-stage gearboxes

Inverter operation						i	Product		Cooling	
M _{2, max} [Nm]	n _{2, th} [r/min]	M ₂ [Nm]	n _{2, eto} [r/min]	c	J [kgcm ²]		MPG	MCS		
390	68	228	68	1.7	10.000	20.000	300	12H14	forced	59
390	68	228	68	1.7	11.000	20.000	300	14D14	forced	59
390	66	165	66	2.4	6.700	25.000	300	12D17	forced	59
390	64	202	64	1.9	6.200	50.000	300	12D41	natural	50
390	64	283	64	1.4	6.200	50.000	300	12D35	forced	59
390	64	360	64	1.1	9.500	50.000	300	12H35	natural	50
390	60	219	60	1.8	11.000	25.000	300	14D15	natural	50
390	60	242	60	1.6	10.000	25.000	300	12H15	natural	50
390	60	242	60	1.6	10.000	25.000	300	12H15	natural	50
390	60	378	60	1.0	9.500	50.000	300	12H30	natural	50
390	60	378	60	1.0	17.000	25.000	300	14H15	natural	50
390	59	185	59	2.1	6.400	28.000	300	12D17	forced	59
390	58	353	58	1.1	11.000	50.000	300	14D36	natural	50
390	56	179	56	2.2	6.400	35.000	300	12D20	natural	50
390	56	179	56	2.2	6.400	35.000	300	12D20	natural	50
390	54	246	54	1.6	11.000	28.000	300	14D15	natural	50
390	54	271	54	1.4	9.700	28.000	300	12H15	natural	50
390	54	271	54	1.4	9.700	28.000	300	12H15	natural	50
390	54	286	54	1.4	10.000	25.000	300	12H14	forced	59
390	54	286	54	1.4	11.000	25.000	300	14D14	forced	59
390	49	205	49	1.9	6.200	40.000	300	12D20	natural	50
390	49	205	49	1.9	6.200	40.000	300	12D20	natural	50
390	48	320	48	1.2	9.700	28.000	300	12H14	forced	59
390	48	320	48	1.2	11.000	28.000	300	14D14	forced	59
390	47	231	47	1.7	6.400	35.000	300	12D17	forced	59
390	43	307	43	1.3	11.000	35.000	300	14D15	natural	50
390	43	339	43	1.1	9.700	35.000	300	12H15	natural	50
390	43	339	43	1.1	9.700	35.000	300	12H15	natural	50
390	41	264	41	1.5	6.200	40.000	300	12D17	forced	59
390	39	256	39	1.5	6.200	50.000	300	12D20	natural	50
390	39	256	39	1.5	6.200	50.000	300	12D20	natural	50
390	38	351	38	1.1	11.000	40.000	300	14D15	natural	50
390	38	387	38	1.0	9.500	40.000	300	12H15	natural	50
390	38	387	38	1.0	9.500	40.000	300	12H15	natural	50
390	33	330	33	1.2	6.200	50.000	300	12D17	forced	59

6.2.4

MPG planetary geared motors

Technical data



Dimensions, notes

Notes on the dimensions

The following legend shows the layout of the dimension sheets.

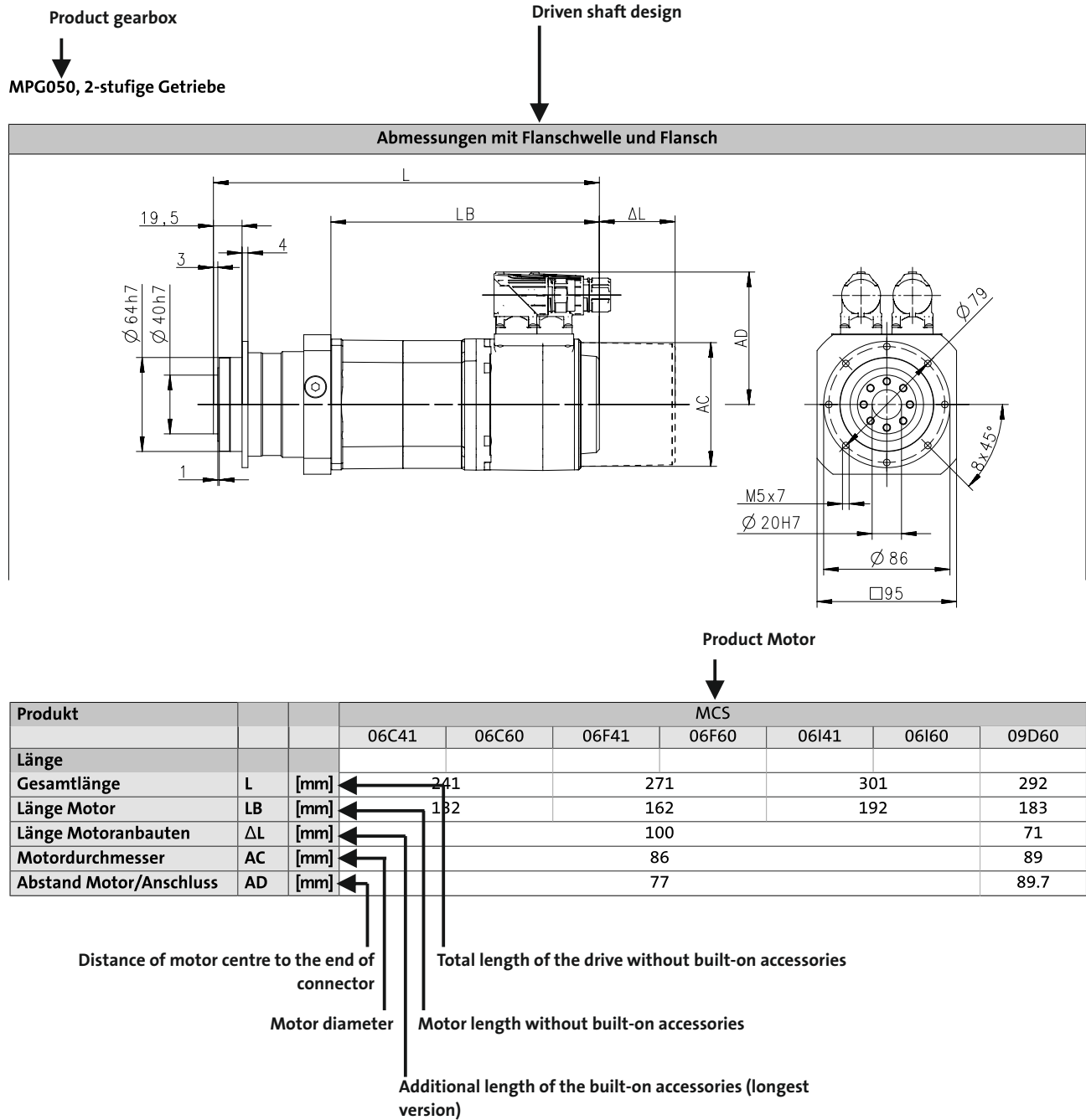

6.2.4

MPG planetary geared motors

Technical data



Dimensions, self-ventilated motors

MPG050, 1-stage gearboxes

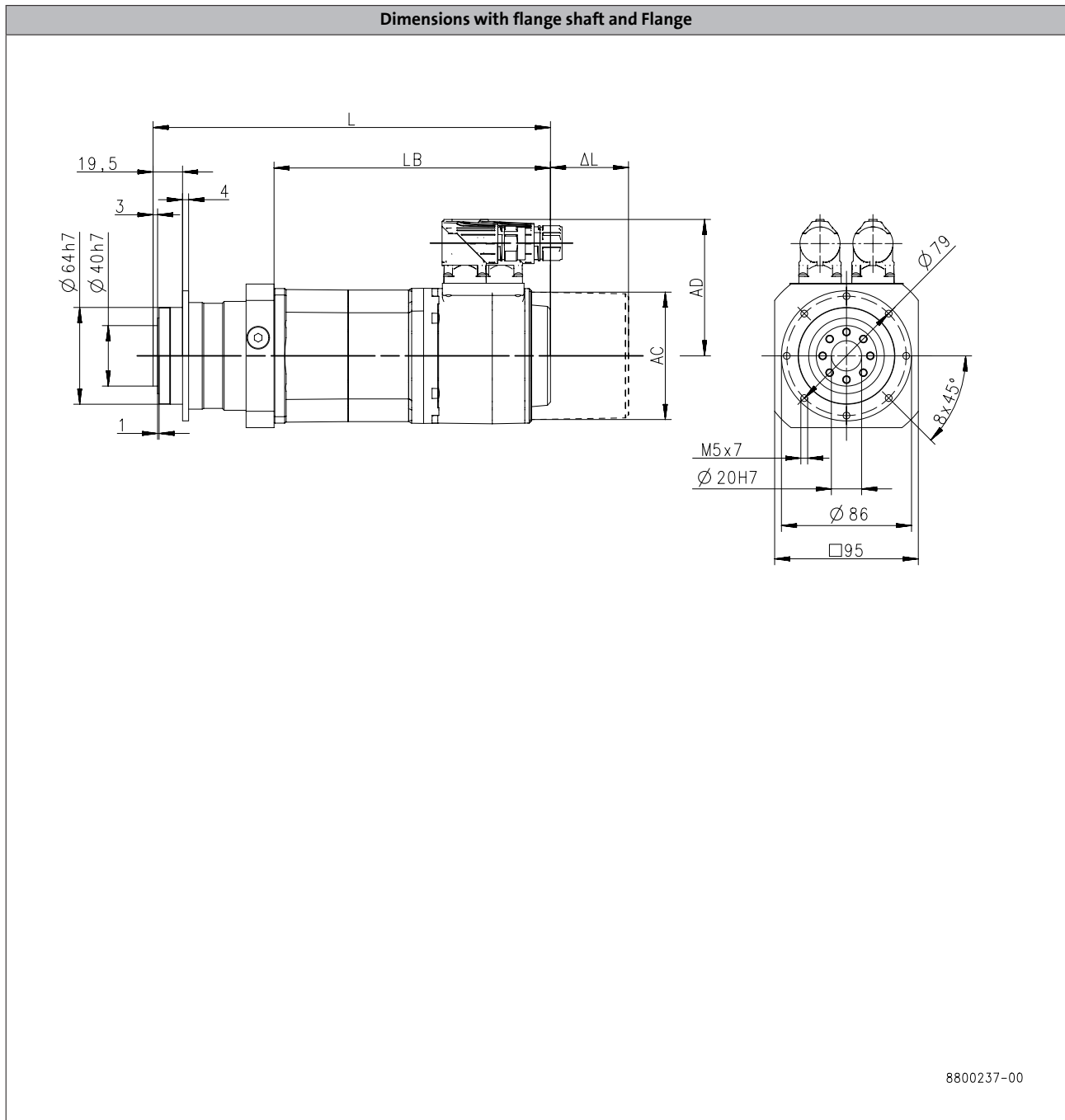

6.2.4

Product			MCS							
			06C41	06C60	06F41	06F60	06I41	06I60	09D41	09D60
Length										
Total length	L	[mm]	212		242		272		263	
Motor length	LB	[mm]	132		162		192		183	
Length of motor options	Δ L	[mm]			100				71	
Motor diameter	AC	[mm]			86				89	
Distance motor/connection	AD	[mm]			77				89.7	

MPG planetary geared motors

Technical data



Dimensions, self-ventilated motors

MPG050, 1-stage gearboxes

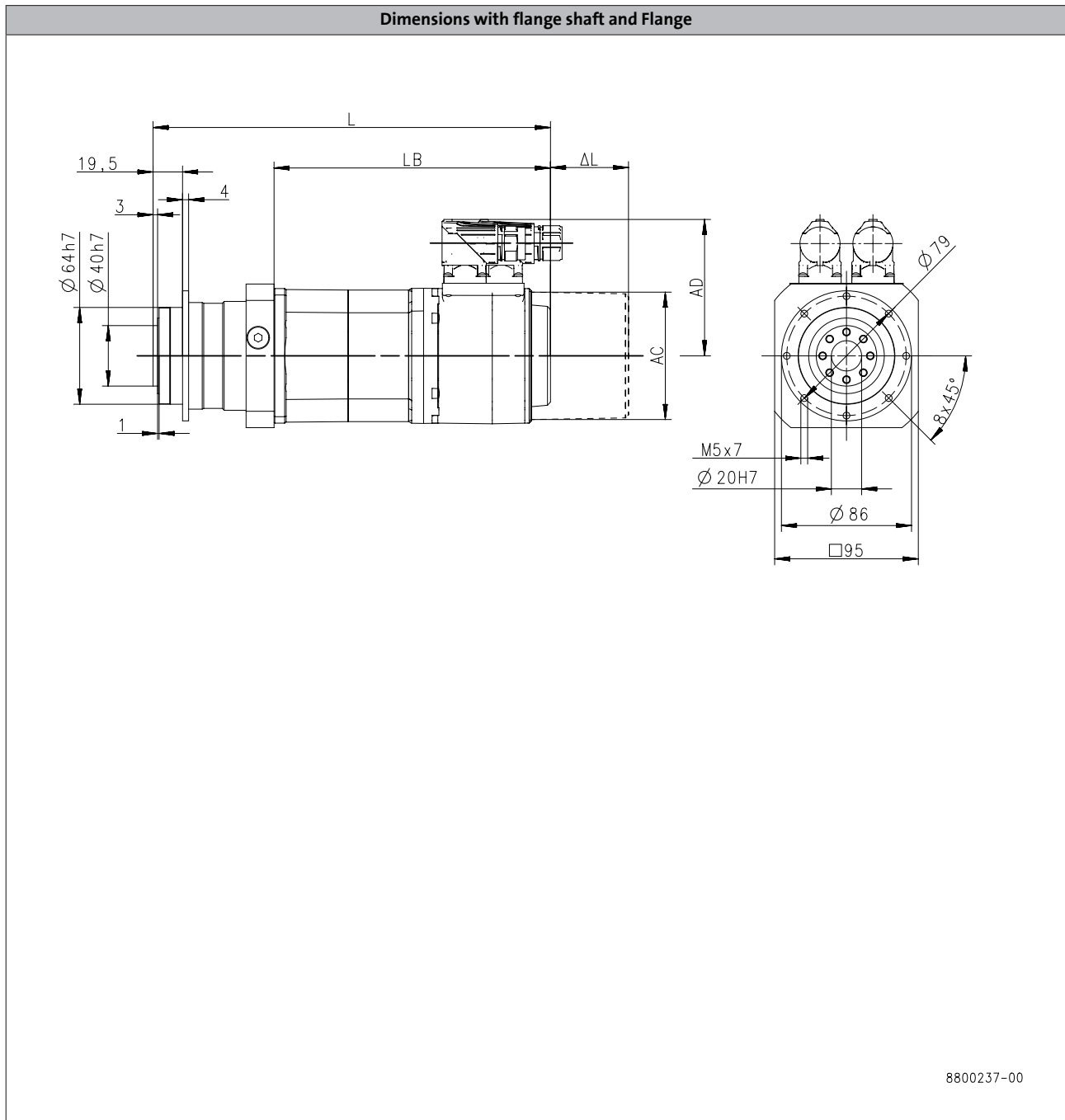

Product			MCS							
			09F38	09F60	09H41	09H60	09L41	09L51	12D20	12D41
Length										
Total length	L	[mm]	283		303		343		277	
Motor length	LB	[mm]	203		223		263		188	
Length of motor options	Δ L	[mm]			71				69	
Motor diameter	AC	[mm]			89				116	
Distance motor/connection	AD	[mm]			89.7				105	

MPG planetary geared motors

Technical data



Dimensions, self-ventilated motors

MPG050, 2-stage gearboxes

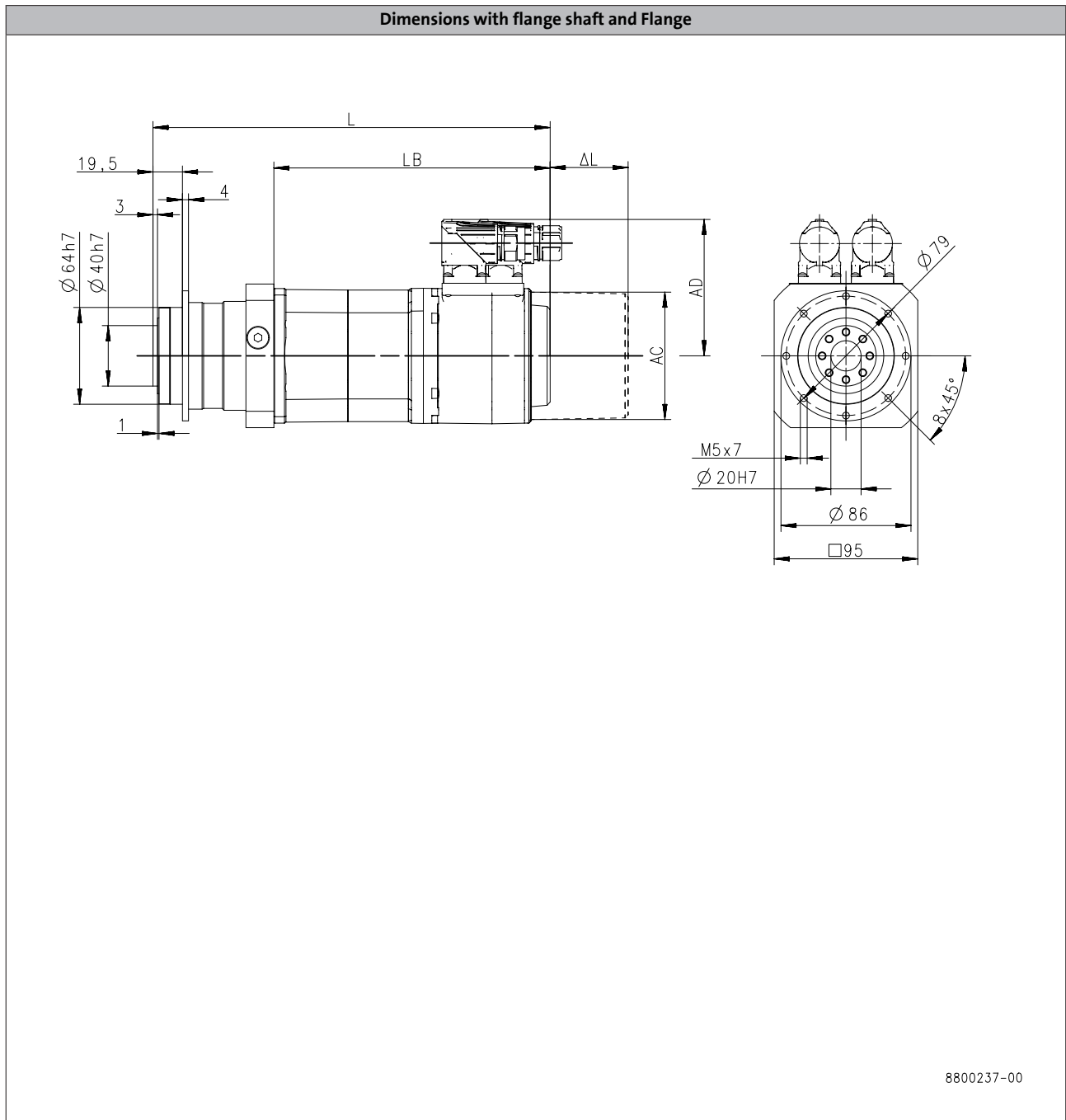

6.2.4

Product			MCS						
			06C41	06C60	06F41	06F60	06I41	06I60	09D60
Length									
Total length	L	[mm]	241		271		301		292
Motor length	LB	[mm]	132		162		192		183
Length of motor options	ΔL	[mm]			100				71
Motor diameter	AC	[mm]			86				89
Distance motor/connection	AD	[mm]			77				89.7

MPG planetary geared motors

Technical data



Dimensions, self-ventilated motors

MPG100, 1-stage gearboxes

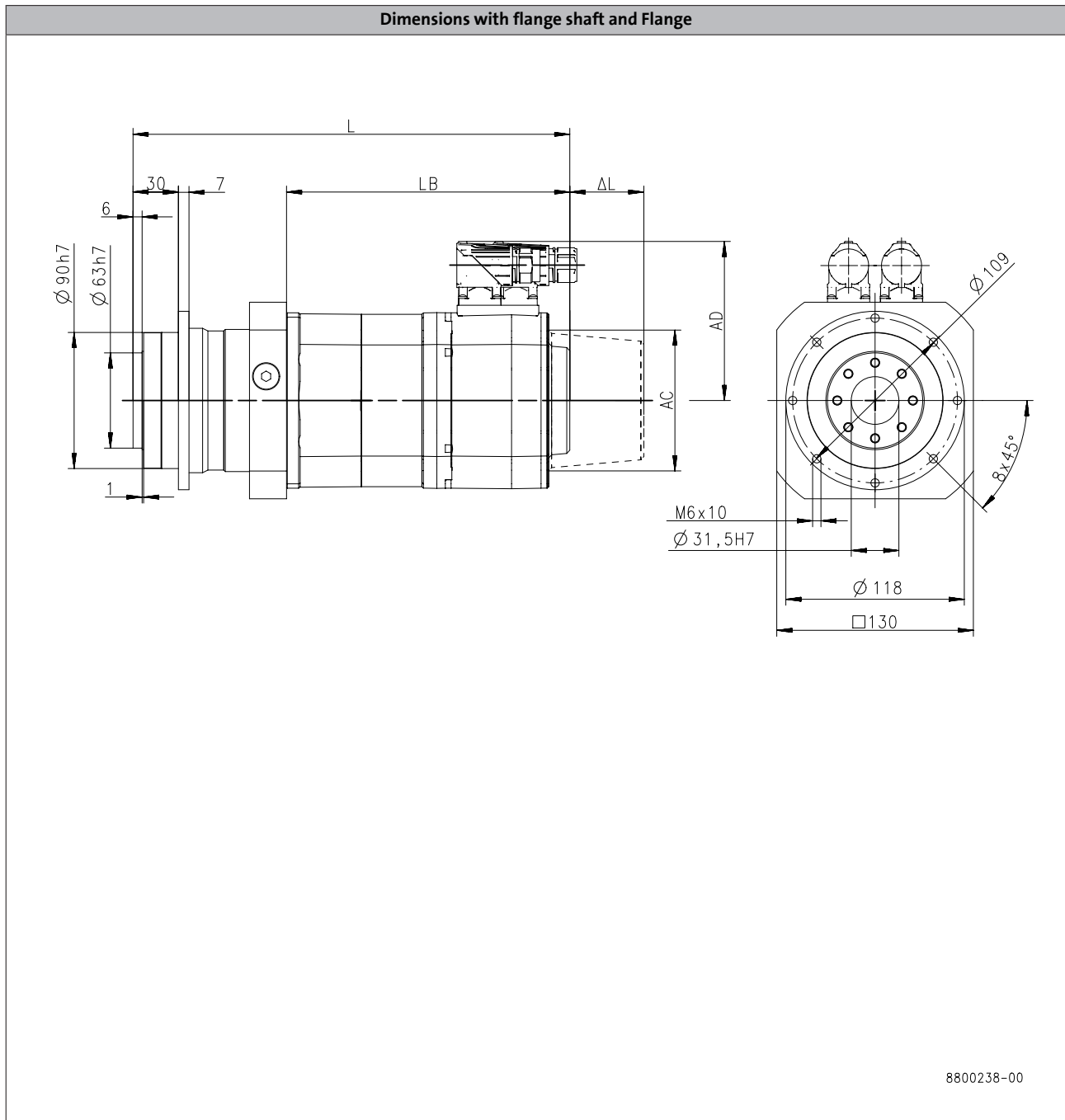

Product			MCS							
			09D41	09D60	09F38	09F60	09H41	09H60	09L41	09L51
Length										
Total length	L	[mm]	285		305			325		365
Motor length	LB	[mm]	183		203			223		263
Length of motor options	Δ L	[mm]				71				
Motor diameter	AC	[mm]				89				
Distance motor/connection	AD	[mm]				89.7				

MPG planetary geared motors

Technical data



Dimensions, self-ventilated motors

MPG100, 1-stage gearboxes

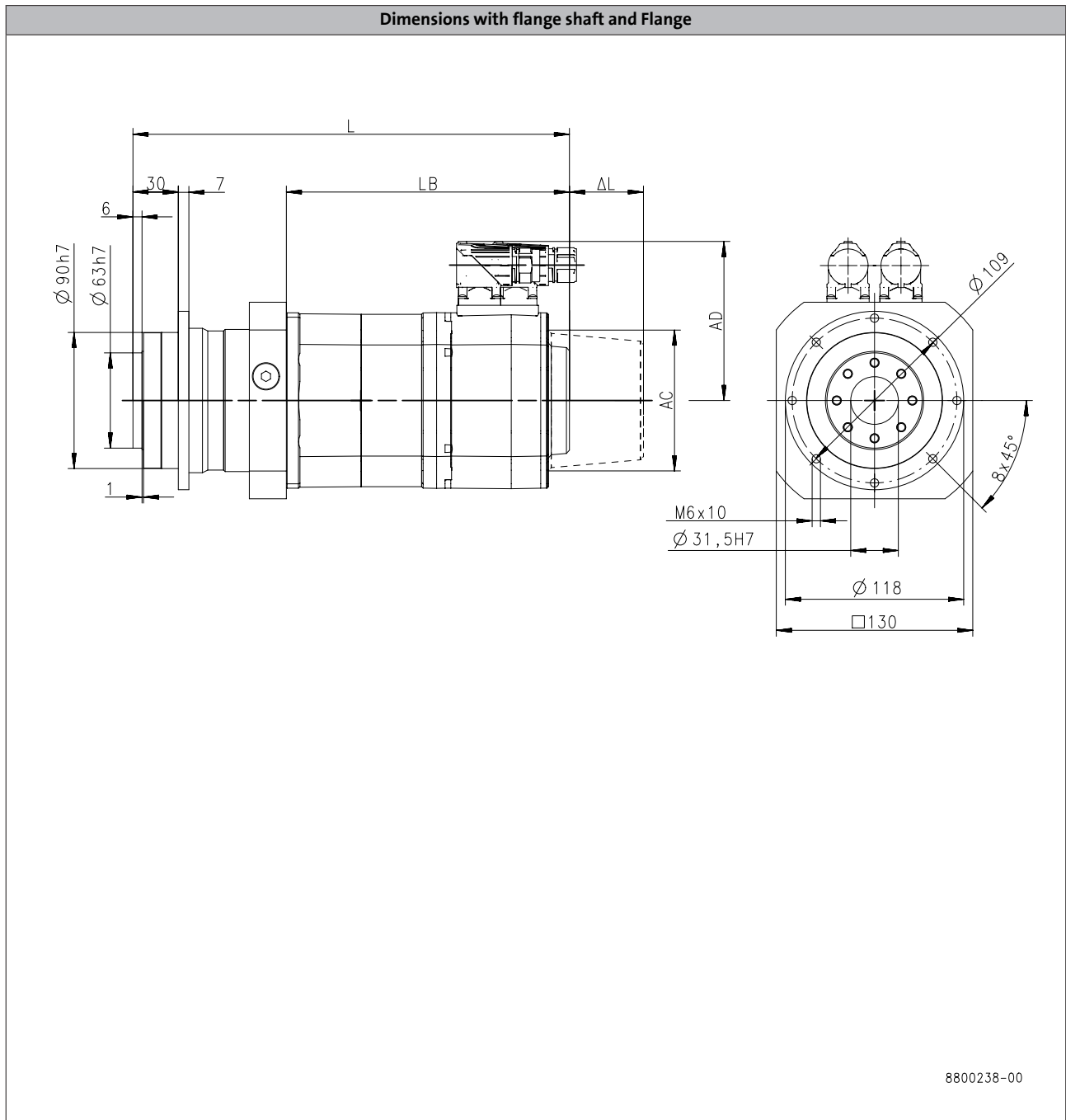

6.2.4

Product			MCS								
			12D20	12D41	12H15	12H30	12H35	12L20	12L41	14D15	14D36
Length											
Total length	L	[mm]	290			330			370		313
Motor length	LB	[mm]	188			228			268		201
Length of motor options	Δ L	[mm]				69					78
Motor diameter	AC	[mm]				116					143
Distance motor/connection	AD	[mm]				105					116.5

MPG planetary geared motors

Technical data



Dimensions, self-ventilated motors

MPG100, 2-stage gearboxes

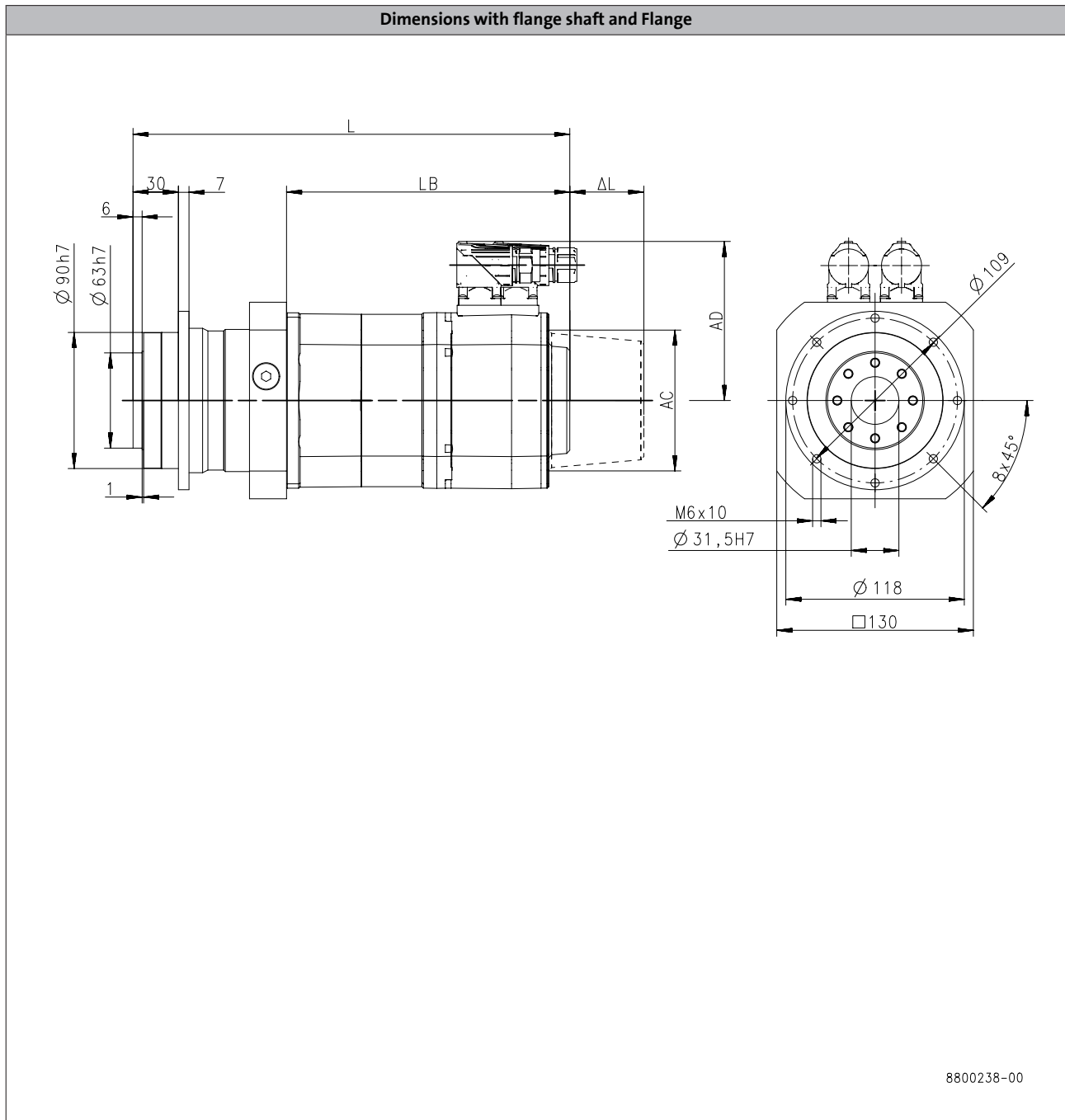

Product			MCS						
			06C41	06C60	06F41	06F60	06I41		06I60
Length									
Total length	L	[mm]	254		284		314		305
Motor length	LB	[mm]	132		162		192		183
Length of motor options	ΔL	[mm]			100				71
Motor diameter	AC	[mm]			86				89
Distance motor/connection	AD	[mm]			77				89.7

MPG planetary geared motors

Technical data



Dimensions, self-ventilated motors

MPG100, 2-stage gearboxes

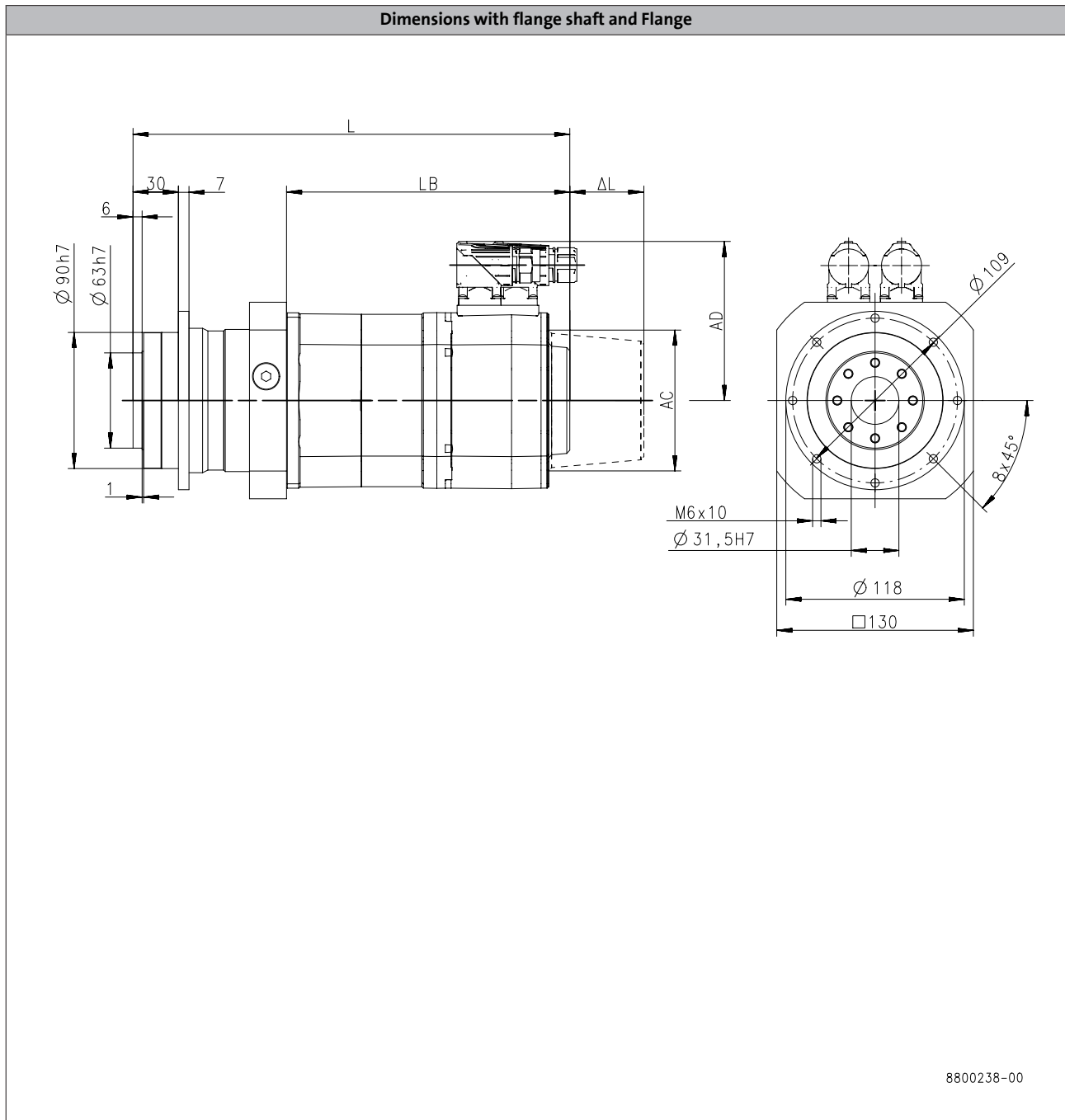

6.2.4

Product			MCS							
			09D60	09F38	09F60	09H41	09H60	09L41	09L51	
Length										
Total length	L	[mm]	305	325		345		385		
Motor length	LB	[mm]	183	203		223		263		
Length of motor options	Δ L	[mm]				71				
Motor diameter	AC	[mm]				89				
Distance motor/connection	AD	[mm]				89.7				

MPG planetary geared motors

Technical data



Dimensions, self-ventilated motors

MPG200, 1-stage gearboxes

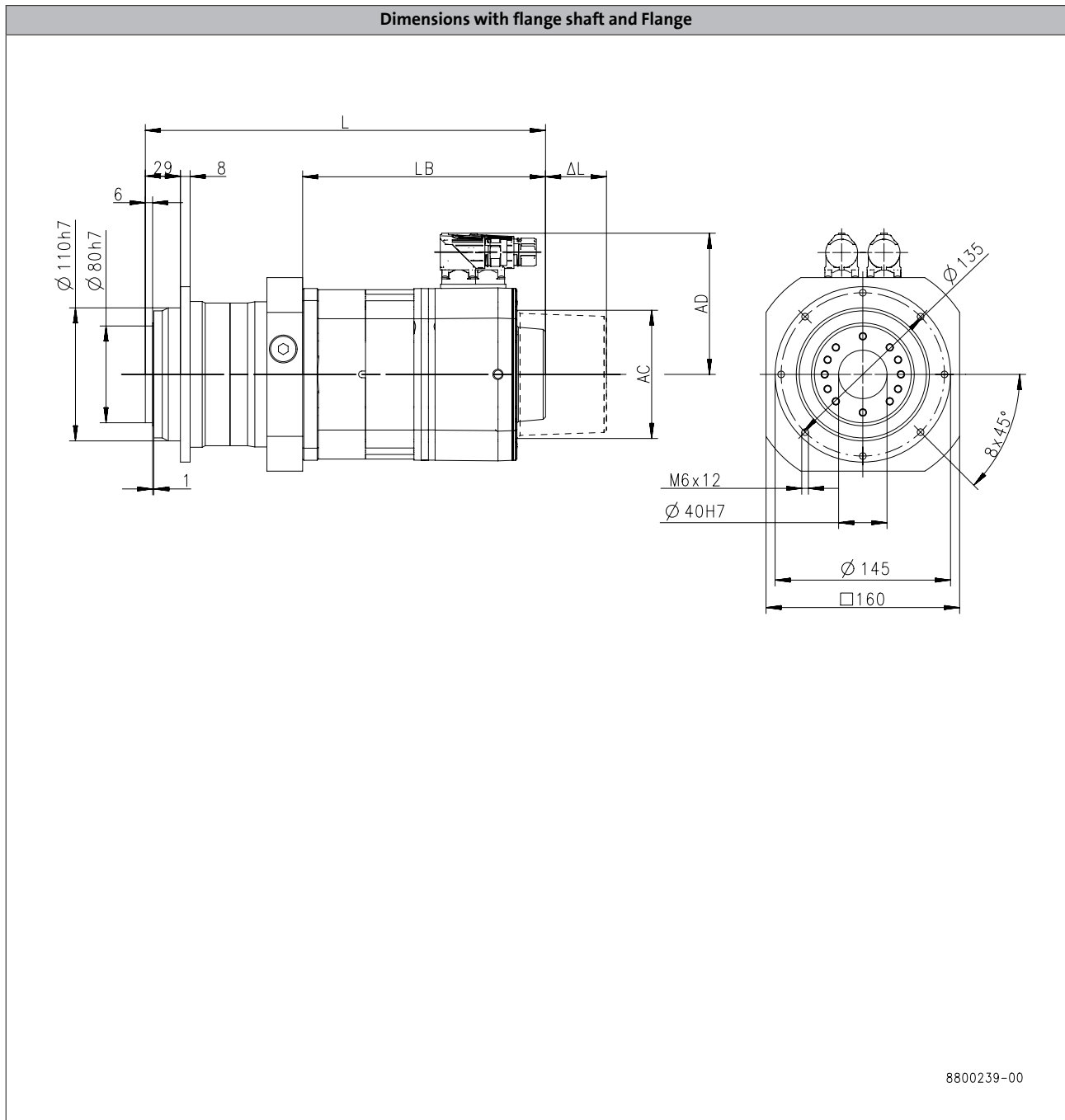

Product			MCS								
			12D20	12D41	12H15	12H30	12H35	12L20	12L41	14D15	14D36
Length											
Total length	L	[mm]	318			358			398		331
Motor length	LB	[mm]	188			228			268		201
Length of motor options	Δ L	[mm]				69					78
Motor diameter	AC	[mm]				116					143
Distance motor/connection	AD	[mm]				105					116.5

MPG planetary geared motors

Technical data



Dimensions, self-ventilated motors

MPG200, 1-stage gearboxes

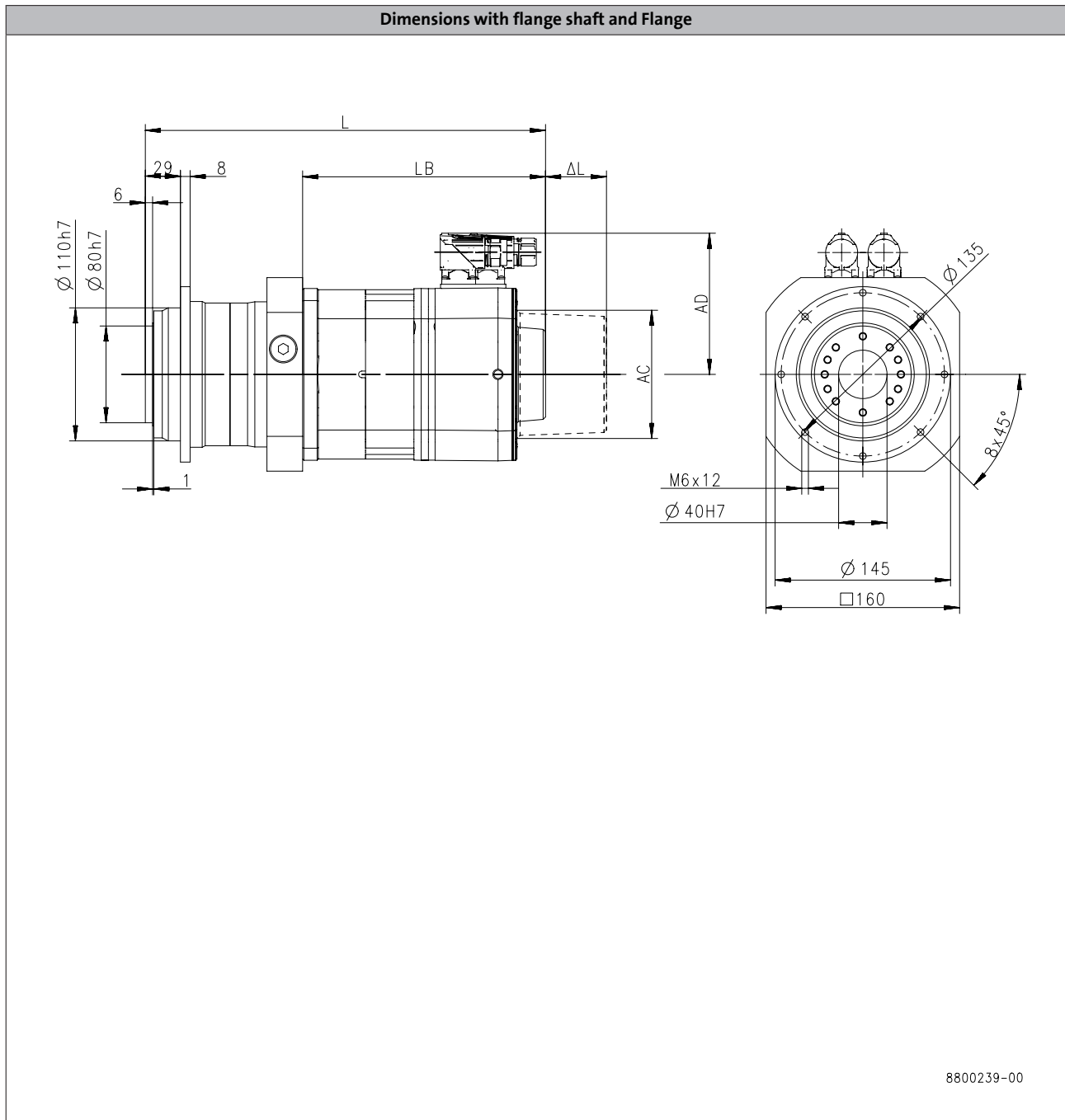

6.2.4

Product			MCS									
			14H15	14H32	14L15	14L32	14P14	14P32	19F14	19F30	19J14	19J30
Length												
Total length	L	[mm]	371		411		451		350		390	
Motor length	LB	[mm]	241		281		321		220		260	
Length of motor options	Δ L	[mm]			78				83		93	
Motor diameter	AC	[mm]			143				192			
Distance motor/connection	AD	[mm]	116.5		146		116.5	146	141.5	171	141.5	171

MPG planetary geared motors

Technical data



Dimensions, self-ventilated motors

MPG200, 2-stage gearboxes

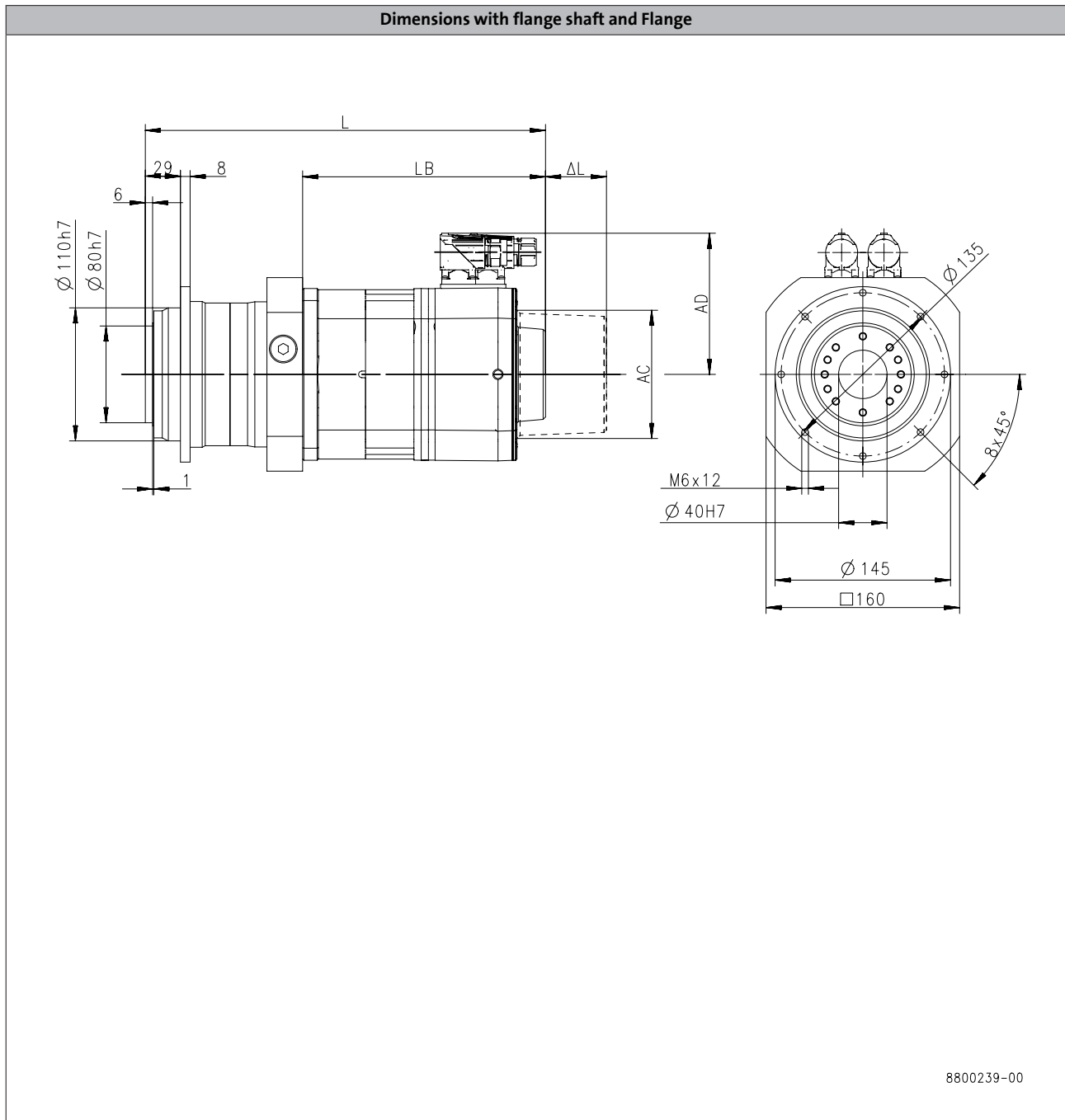

Product			MCS						
			09D41	09D60	09F38	09F60	09H41	09H60	09L41
Length									
Total length	L	[mm]	327		347		367		407
Motor length	LB	[mm]	183		203		223		263
Length of motor options	Δ L	[mm]			71				
Motor diameter	AC	[mm]			89				
Distance motor/connection	AD	[mm]			89.7				

MPG planetary geared motors

Technical data



Dimensions, self-ventilated motors

MPG200, 2-stage gearboxes

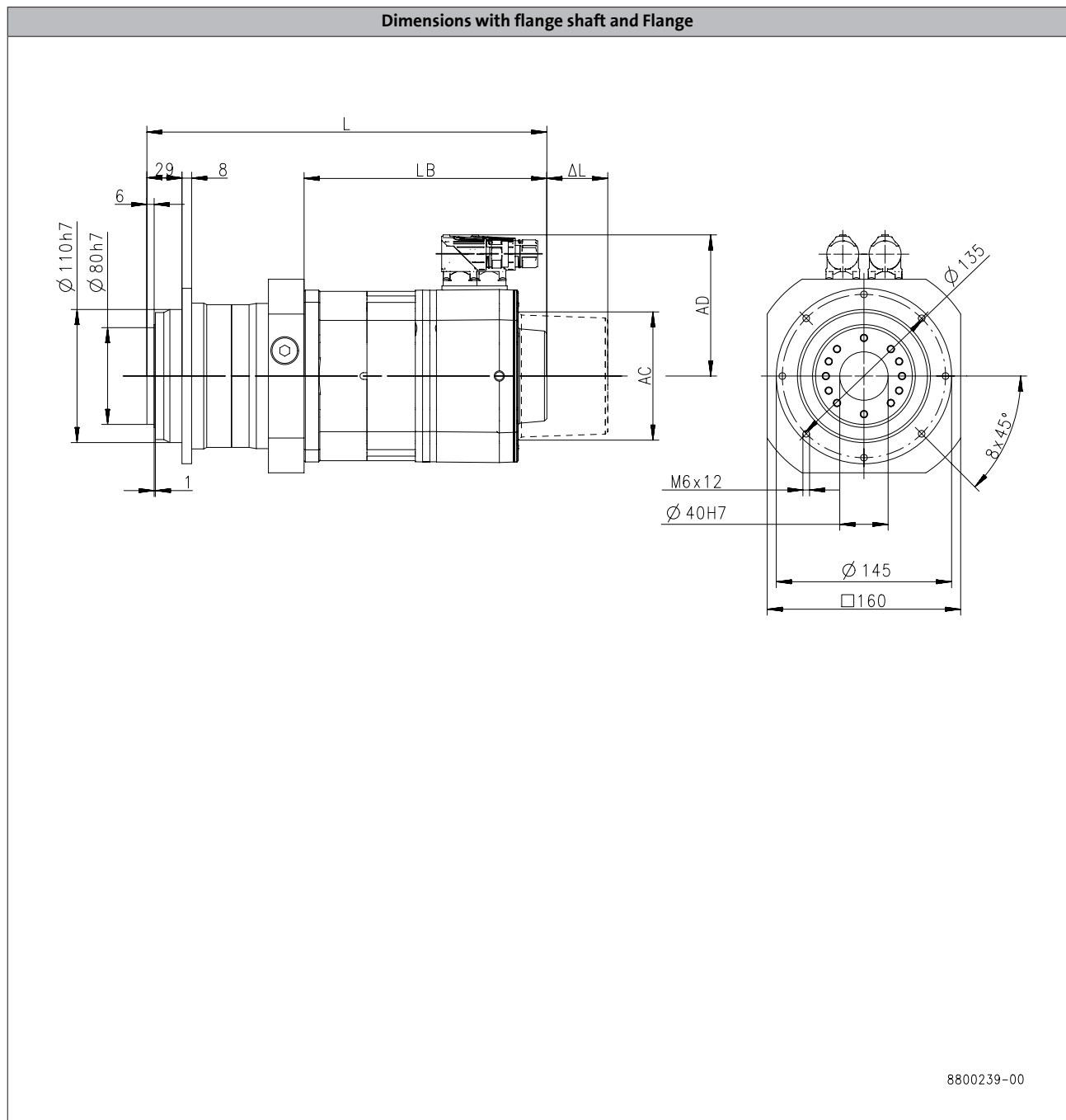

6.2.4

Product			MCS						
			09L51	12D20	12D41	12H15	12H30	12H35	12L41
Length									
Total length	L	[mm]	407	332			372		412
Motor length	LB	[mm]	263	188			228		268
Length of motor options	Δ L	[mm]	71			69			
Motor diameter	AC	[mm]	89			116			
Distance motor/connection	AD	[mm]	89.7			105			

MPG planetary geared motors

Technical data



Dimensions, self-ventilated motors

MPG300, 1-stage gearboxes

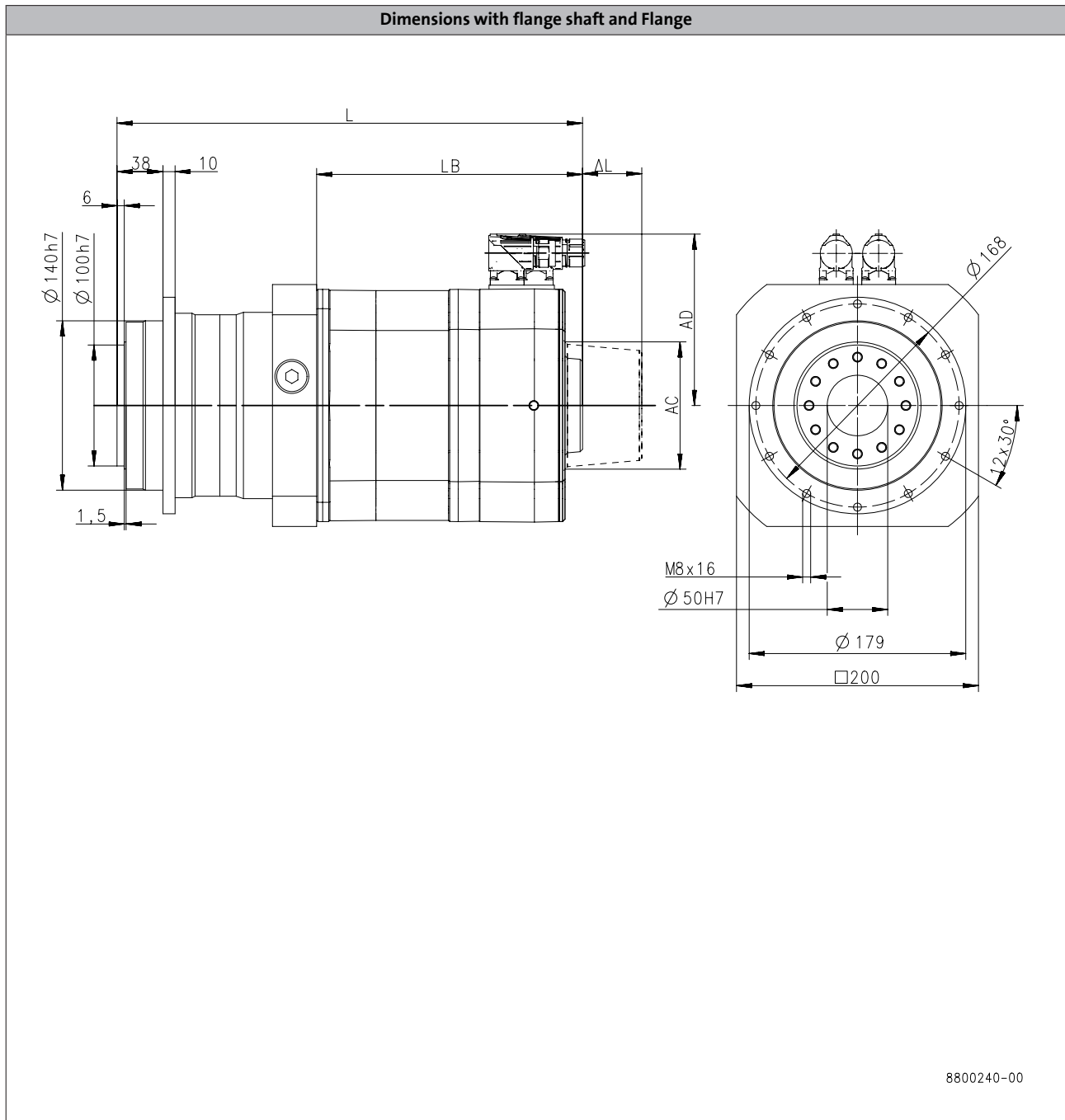

Product			MCS						
			14D15	14D36	14H15	14H32	14L15	14L32	14P14
Length									
Total length	L	[mm]	366		406		446		486
Motor length	LB	[mm]	201		241		281		321
Length of motor options	ΔL	[mm]			78				
Motor diameter	AC	[mm]			143				
Distance motor/connection	AD	[mm]			116.5		146		116.5

MPG planetary geared motors

Technical data



Dimensions, self-ventilated motors

MPG300, 1-stage gearboxes

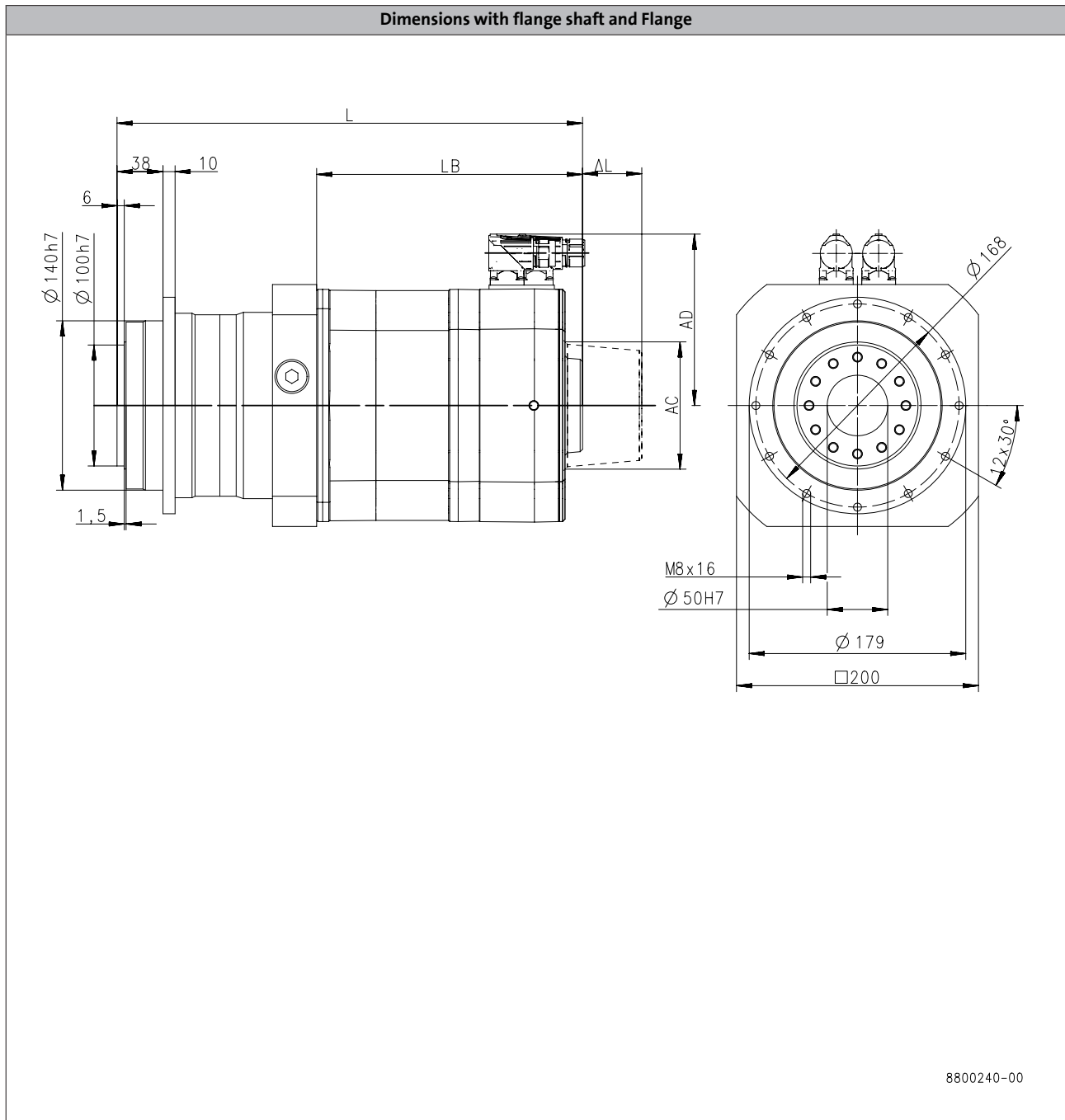

6.2.4

Product	MCS								
			14P32	19F14	19F30	19J14	19J30	19P14	19P30
Length									
Total length	L	[mm]	486	385		425		485	
Motor length	LB	[mm]	321	220		260		320	
Length of motor options	ΔL	[mm]	78	83			93		
Motor diameter	AC	[mm]	143			192			
Distance motor/connection	AD	[mm]	146	141.5	171	141.5	171	141.5	171

MPG planetary geared motors

Technical data



Dimensions, self-ventilated motors

MPG300, 2-stage gearboxes

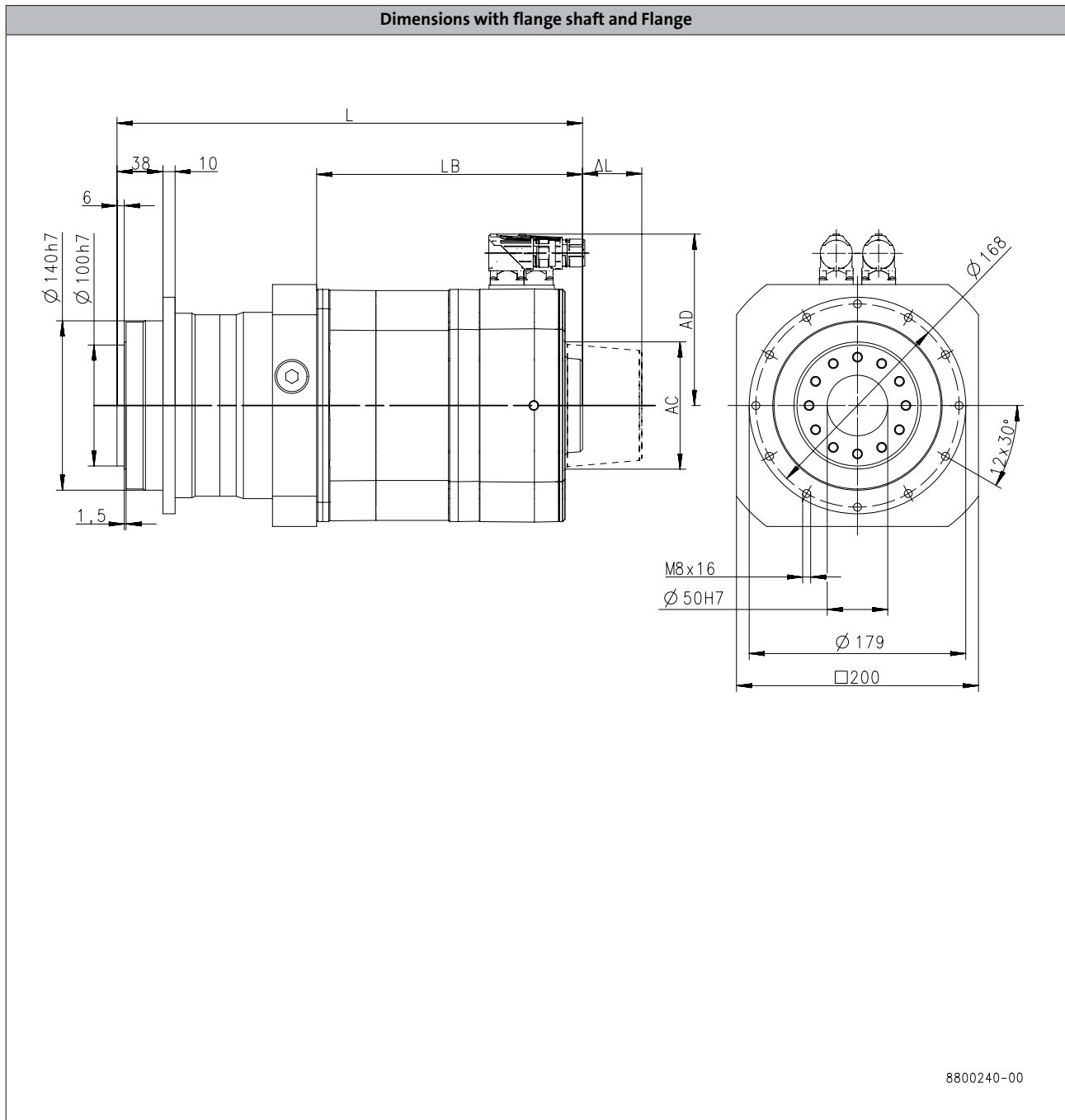

6.2.4

Product			MCS							
			12D20	12D41	12H15	12H30	12H35	12L20	12L41	
Length										
Total length	L	[mm]	372			412			452	
Motor length	LB	[mm]	188			228			268	
Length of motor options	Δ L	[mm]				69				
Motor diameter	AC	[mm]				116				
Distance motor/connection	AD	[mm]				105				

MPG planetary geared motors

Technical data



Dimensions, self-ventilated motors

MPG300, 2-stage gearboxes

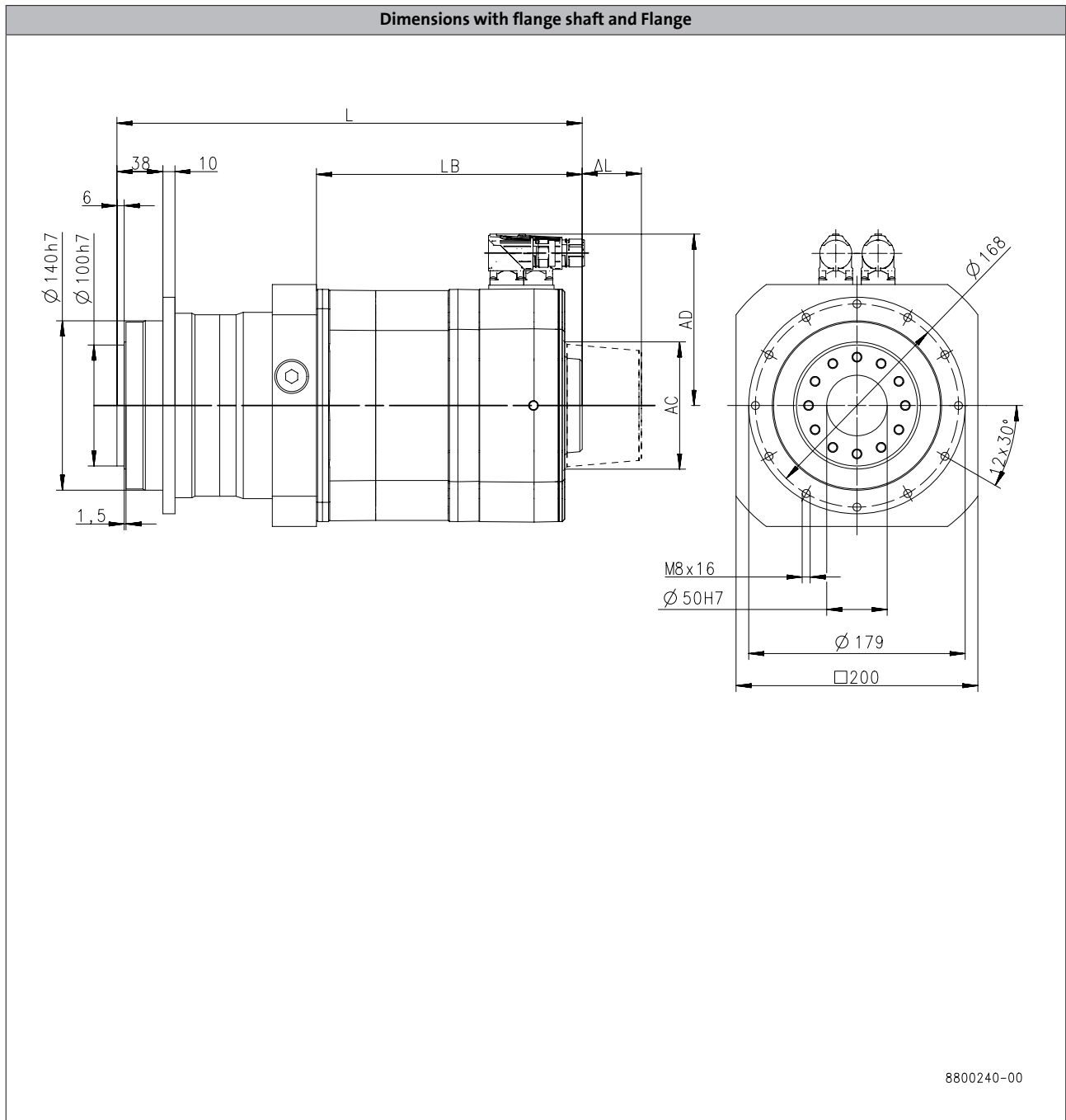

6.2.4

Product			MCS								
			14D15	14D36	14H15	14H32	14L15	14L32	14P32	19F30	
Length											
Total length	L	[mm]	385		425			465		505	404
Motor length	LB	[mm]	201		241			281		321	220
Length of motor options	Δ L	[mm]				78					83
Motor diameter	AC	[mm]				143					192
Distance motor/connection	AD	[mm]			116.5				146		171

MPG planetary geared motors

Technical data



Dimensions, forced ventilated motors

MPG050, 1-stage gearboxes

Dimensions with flange shaft and Flange

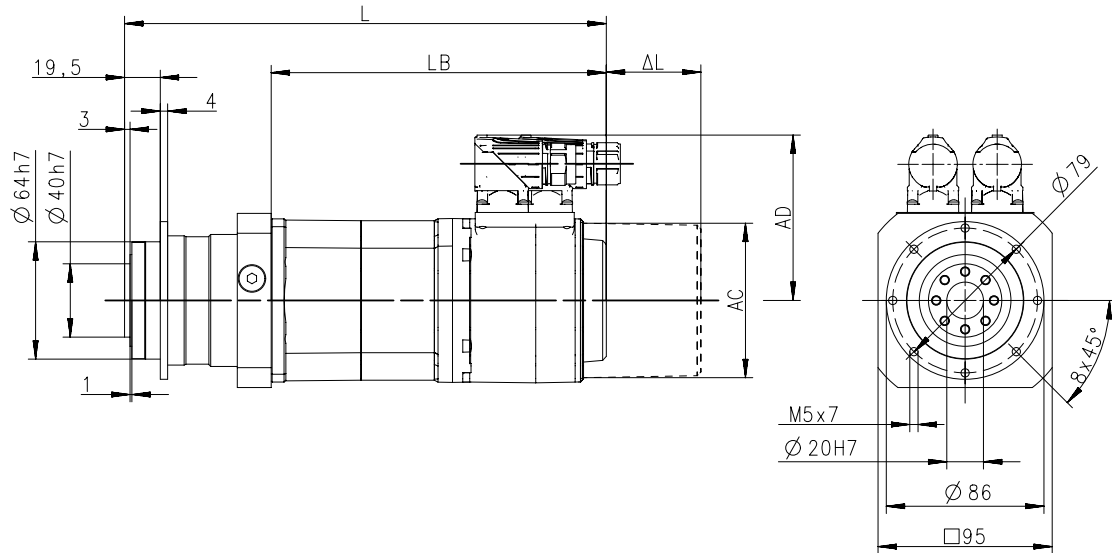

8800237-00

Product			MCS	
			12D17	12D35
Length				
Total length	L	[mm]	350	
Motor length	LB	[mm]	261	
Length of motor options	ΔL	[mm]	63	
Motor diameter	AC	[mm]	140	
Distance motor/connection	AD	[mm]	105	

MPG planetary geared motors

Technical data



Dimensions, forced ventilated motors

MPG100, 1-stage gearboxes

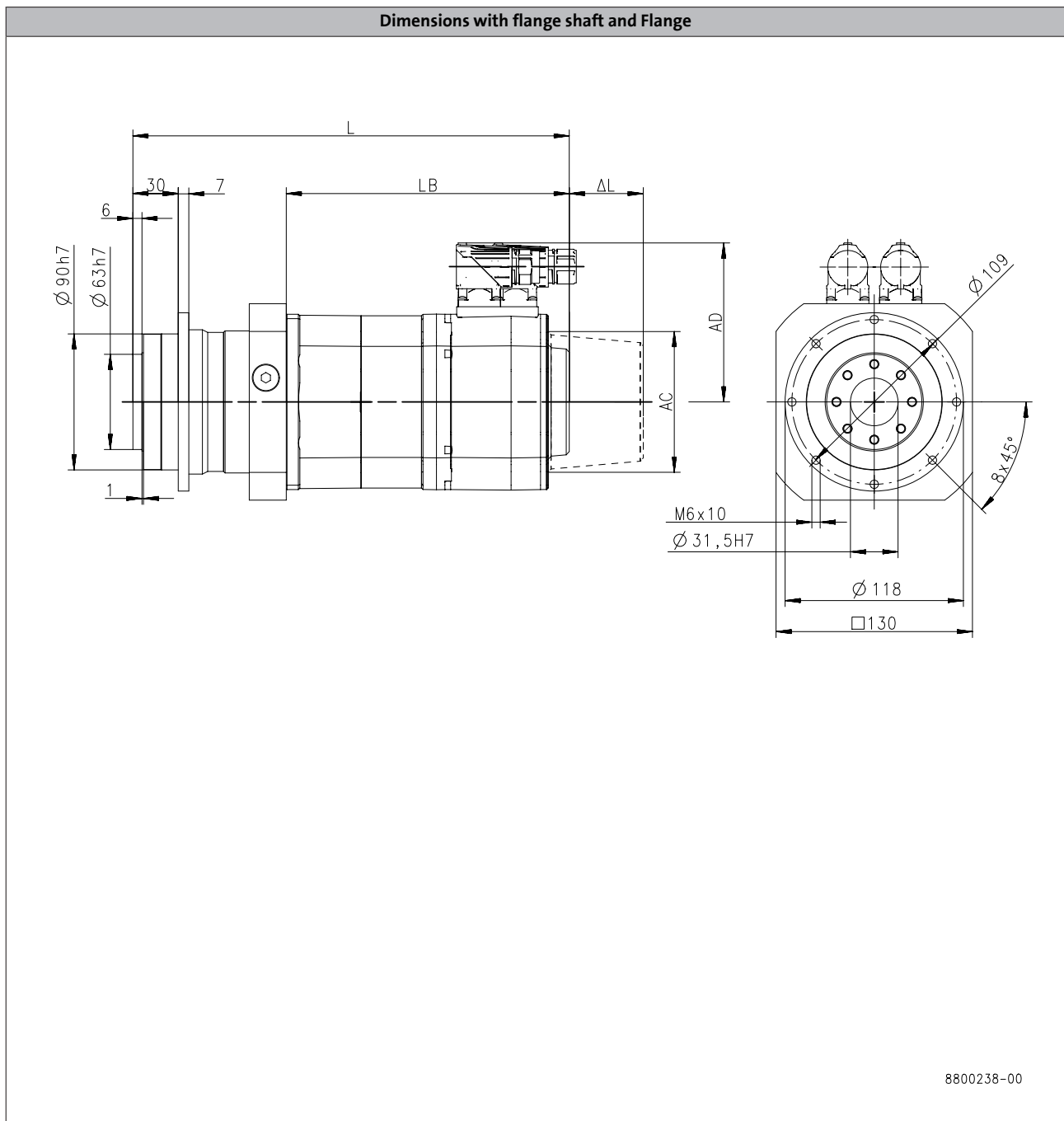

6.2.4

Product			MCS							
			12D17	12D35	12H14	12H34	12L17	12L39	14D14	14D30
Length										
Total length	L	[mm]	363		403		443		401	
Motor length	LB	[mm]	261		301		341		289	
Length of motor options	Δ L	[mm]			63				81.5	
Motor diameter	AC	[mm]			140				167	
Distance motor/connection	AD	[mm]			105				116.5	

MPG planetary geared motors

Technical data



Dimensions, forced ventilated motors

MPG200, 1-stage gearboxes

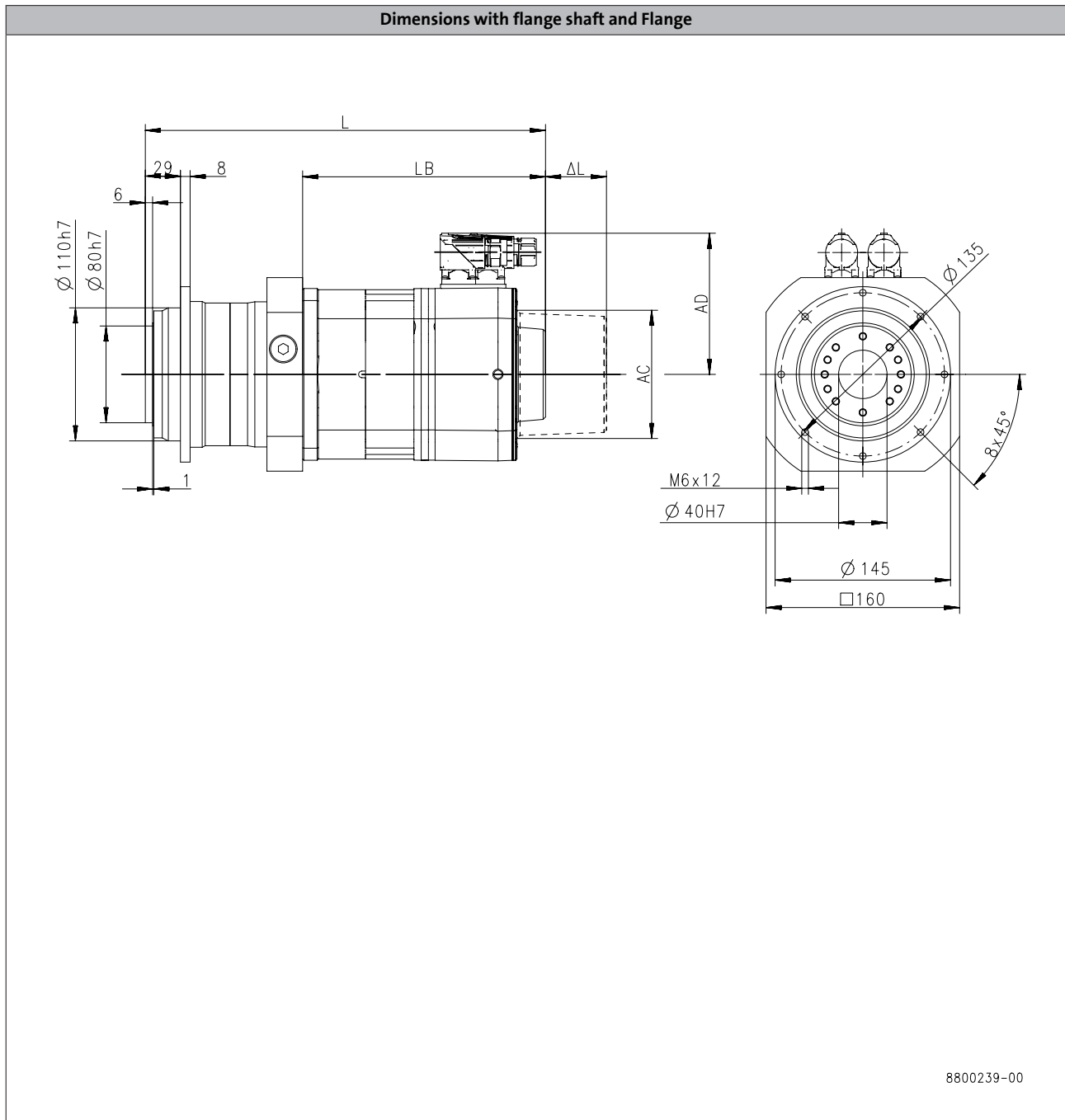

Product			MCS							
			12D17	12D35	12H14	12H34	12L17	12L39	14D14	14D30
Length										
Total length	L	[mm]	391		431		471		419	
Motor length	LB	[mm]	261		301		341		289	
Length of motor options	Δ L	[mm]			63				81.5	
Motor diameter	AC	[mm]			140				167	
Distance motor/connection	AD	[mm]			105				116.5	

MPG planetary geared motors

Technical data



Dimensions, forced ventilated motors

MPG200, 1-stage gearboxes

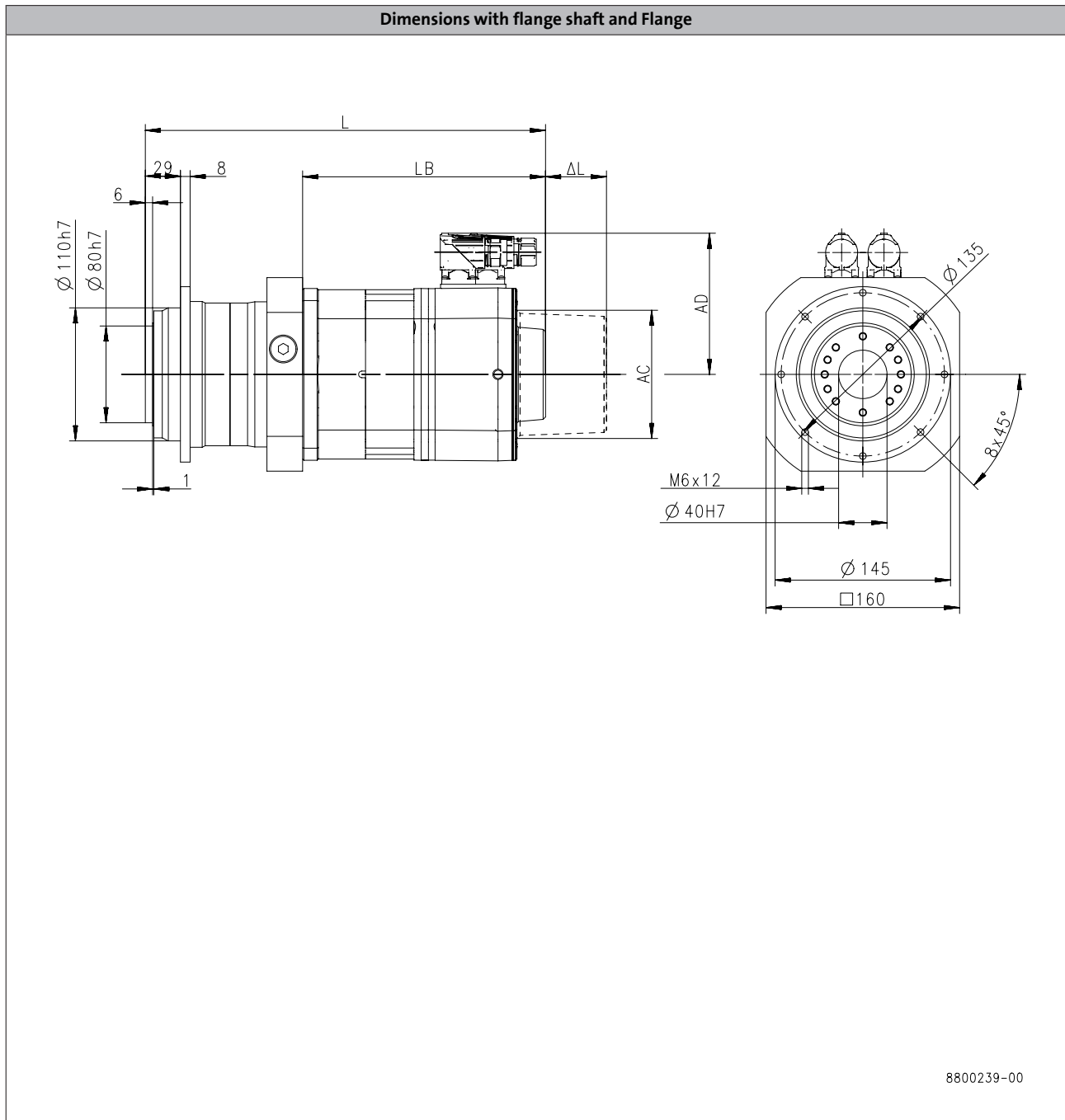

6.2.4

Product			MCS							
			14H12	14H28	14L14	14L30	14P11	14P26	19F12	19F29
Length										
Total length	L	[mm]	459		499		539		457	
Motor length	LB	[mm]	329		369		409		327	
Length of motor options	Δ L	[mm]			81.5				72	
Motor diameter	AC	[mm]			167				212	
Distance motor/connection	AD	[mm]	116.5	146	116.5	146	116.5	146	141.5	171

MPG planetary geared motors

Technical data



Dimensions, forced ventilated motors

MPG200, 2-stage gearboxes

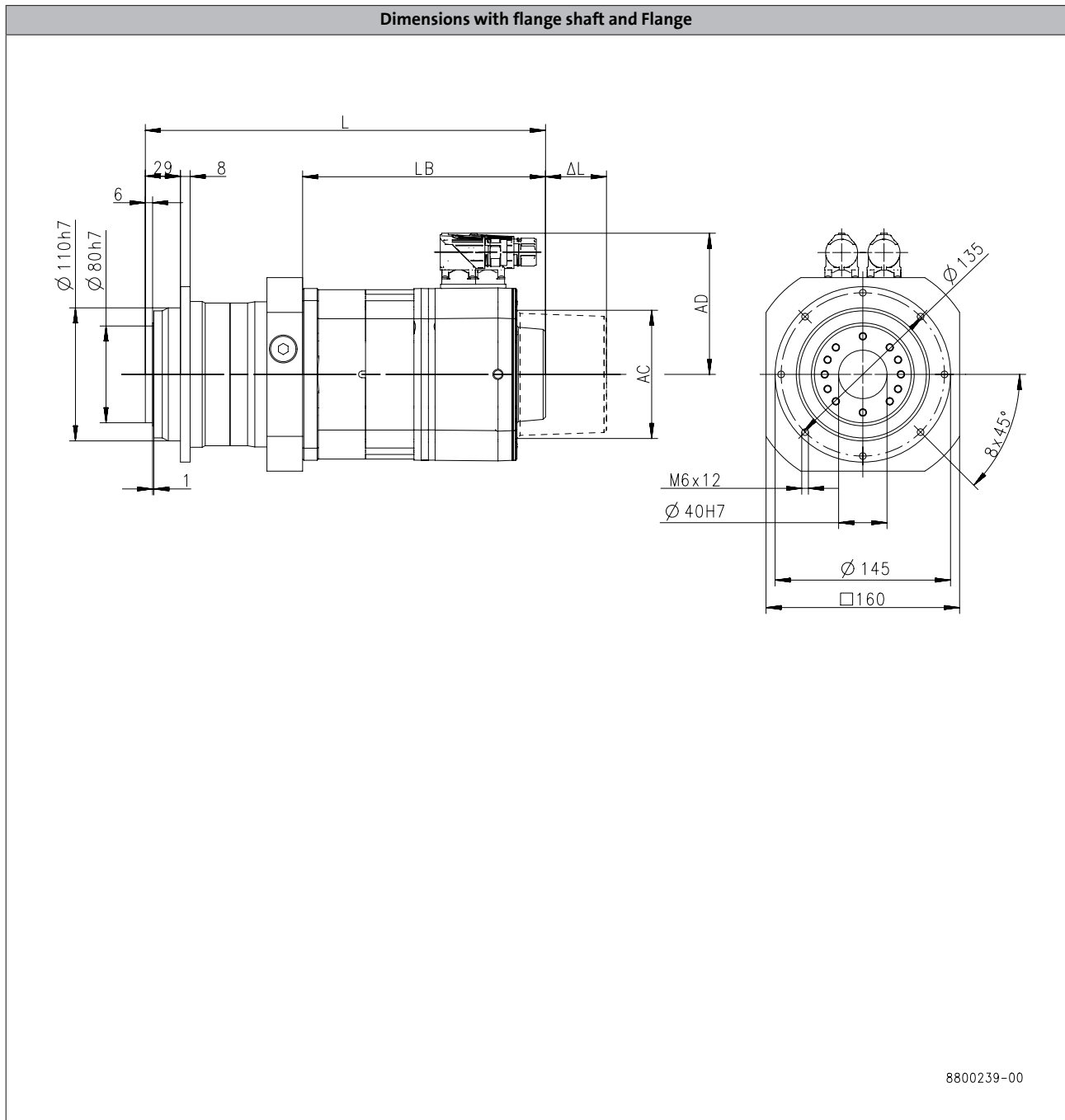

Product	MCS			
	12D17	12D35	12H14	12H34
Length				
Total length	L	[mm]	405	445
Motor length	LB	[mm]	261	301
Length of motor options	Δ L	[mm]	63	
Motor diameter	AC	[mm]	140	
Distance motor/connection	AD	[mm]	105	

MPG planetary geared motors

Technical data



Dimensions, forced ventilated motors

MPG300, 1-stage gearboxes

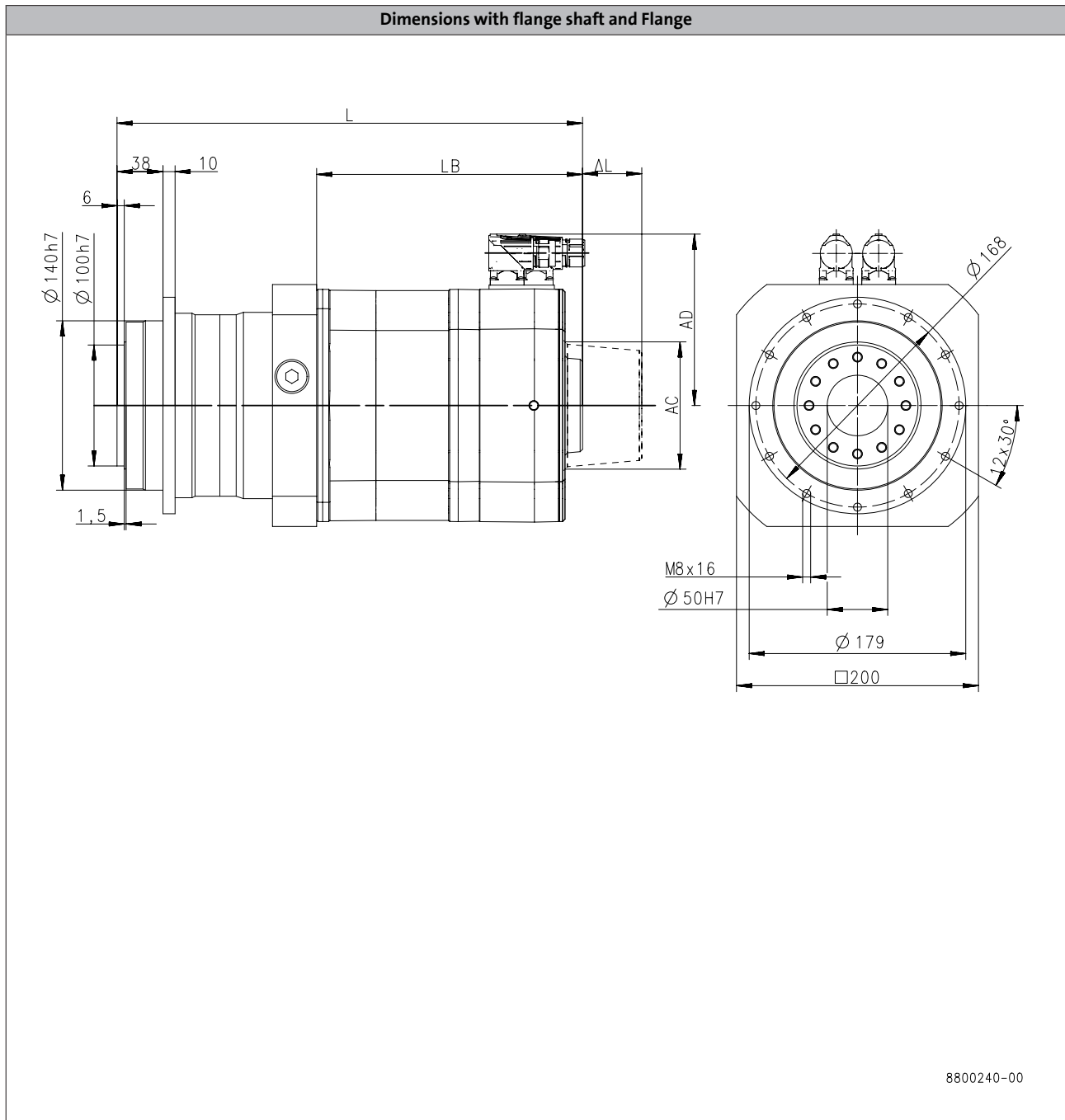

6.2.4

Product			MCS						
			14D14	14D30	14H12	14H28	14L14	14L30	14P11
Length									
Total length	L	[mm]	454		494		534		574
Motor length	LB	[mm]	289		329		369		409
Length of motor options	ΔL	[mm]			81.5				
Motor diameter	AC	[mm]			167				
Distance motor/connection	AD	[mm]		116.5		146	116.5	146	116.5

MPG planetary geared motors

Technical data



Dimensions, forced ventilated motors

MPG300, 1-stage gearboxes

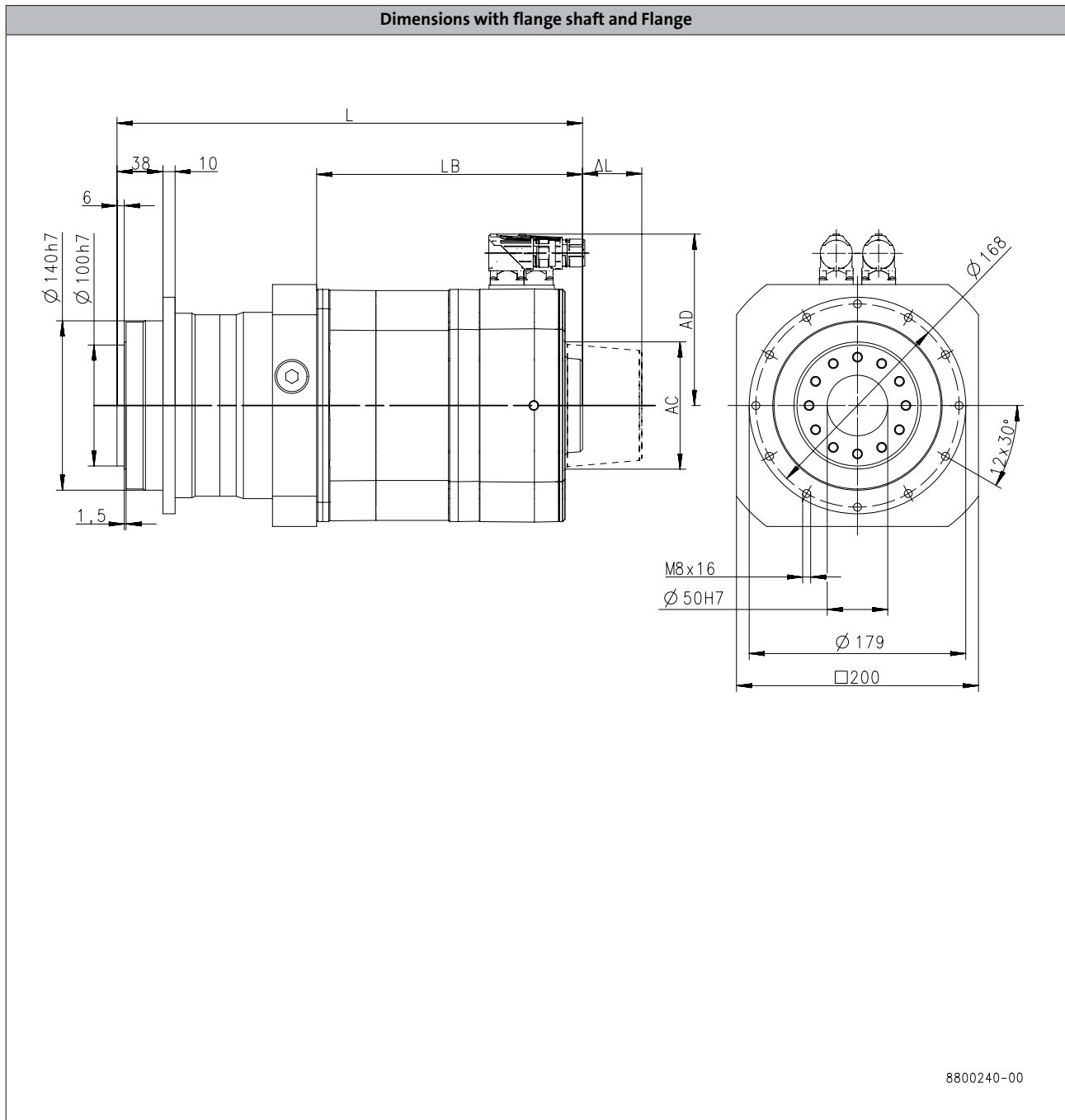

Product			MCS						
			14P26	19F12	19F29	19J12	19J29	19P12	19P29
Length									
Total length	L	[mm]	574	492		532		592	
Motor length	LB	[mm]	409	327		367		427	
Length of motor options	Δ L	[mm]	81.5	72			82		
Motor diameter	AC	[mm]	167			212			
Distance motor/connection	AD	[mm]	146	141.5			171		

MPG planetary geared motors

Technical data



Dimensions, forced ventilated motors

MPG300, 2-stage gearboxes

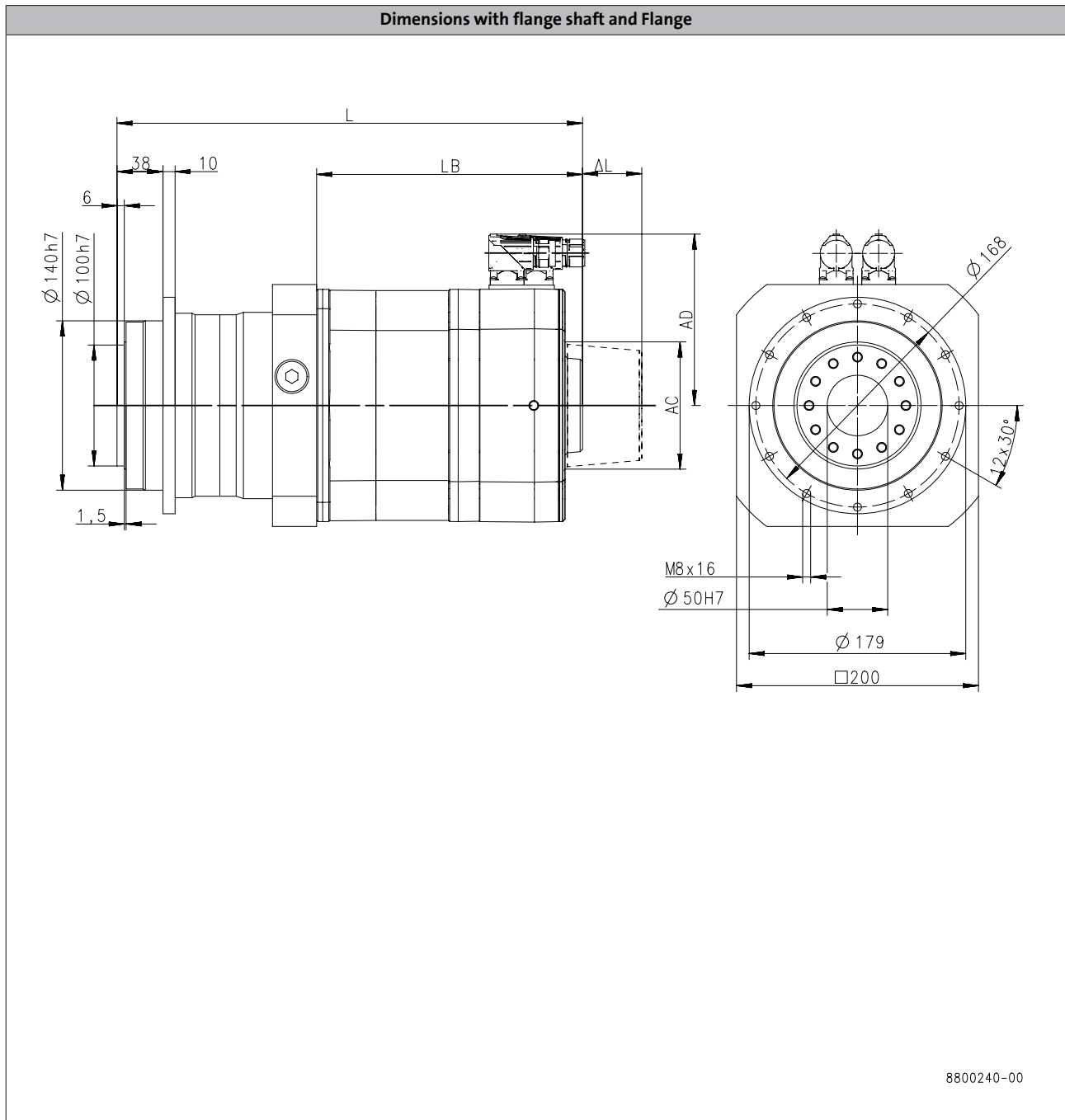

6.2.4

Product			MCS										
			12D17	12D35	12H14	12H34	12L17	12L39	14D14	14D30	14H12	14H28	14L30
Length													
Total length	L	[mm]	445		485		525		473		513		553
Motor length	LB	[mm]	261		301		341		289		329		369
Length of motor options	ΔL	[mm]			63						81.5		
Motor diameter	AC	[mm]			140						167		
Distance motor/connection	AD	[mm]			105				116.5			146	

MPG planetary geared motors

Technical data



Weights, self-ventilated motors

1-stage gearboxes

				MCS								
				06C41 06C60	06F41 06F60	06I41 06I60	09D41 09D60	09F38 09F60	09H41 09H60	09L41 09L51	12D20 12D41	12H15 12H30 12H35
MPG	050	m	[kg]	3.3	3.7	4.4	5.8	6.7	7.6	9.4	7.9	
	100	m	[kg]				8.2	9.1	10	12	10	13
	200	m	[kg]								13	16

				MCS								
				12L20 12L41	14D15 14D36	14H15 14H32	14L15 14L32	14P14 14P32	19F14 19F30	19J14 19J30	19P14 19P30	
MPG	100	m	[kg]	16	15							
	200	m	[kg]	19	17	22	27	32	30	37		
	300	m	[kg]		24	29	34	38	36	44	54	

2-stage gearboxes

				MCS								
				06C41 06C60	06F41 06F60	06I41 06I60	09D41	09D60	09F38 09F60	09H41 09H60	09L41 09L51	12D20 12D41
MPG	050	m	[kg]	23		24		25				
	100	m	[kg]	6.1	6.5	7.2	8.6		9.5	10	12	
	200	m	[kg]				11		12	13	15	13
	300	m	[kg]									21

				MCS							
				12H15 12H30 12H35	12L20	12L41	14D15 14D36	14H15 14H32	14L15 14L32	14P32	19F30
MPG	200	m	[kg]	16		20					
	300	m	[kg]	24	27		25	30	34	39	37

MPG planetary geared motors

Technical data



Weights, forced ventilated motors

1-stage gearboxes

				MCS								
				12D17 12D35	12H14 12H34	12L17 12L39	14D14 14D30	14H12 14H28	14L14 14L30	14P11 14P26 19F12 19F29	19J12 19J29	19P12 19P29
MPG	050	m	[kg]	10								
	100	m	[kg]	12	16	19	18					
	200	m	[kg]	15	18	21		26	31	36		
	300	m	[kg]				28	33	38	42	50	60

2-stage gearboxes

				MCS				
				12D17 12D35	12H14 12H34	12L17 12L39 14D14 14D30	14H12 14H28	14L30
MPG	200	m	[kg]	16	19			
	300	m	[kg]	23	26	29	34	38

MPG planetary geared motors

Technical data



Surface and corrosion protection

For optimum protection of geared motors against ambient conditions, the surface and corrosion protection system (OKS) offers tailor-made solutions.

Various surface coatings combined with other protective measures ensure that the geared motors operate reliably even at high air humidity, in outdoor installations or in the presence of atmospheric impurities. Any colour from the RAL Classic collection can be chosen for the top coat. The geared motors are also available unpainted (no surface and corrosion protection).

Surface and corrosion protection	Applications	Measures
OKS-G (primed)	<ul style="list-style-type: none"> • Dependent on subsequent top coat applied 	<ul style="list-style-type: none"> • 2K PUR priming coat (grey) • Zinc-coated screws • Rust-free breather elements Optional measures <ul style="list-style-type: none"> • Stainless steel nameplate

Structure of surface coating

Surface and corrosion protection	Surface coating
	Structure
Without OKS(uncoated)	Dipping primed gearbox
OKS-G (primed)	Dipping primed gearbox 2K PUR priming coat

MPG planetary geared motors

Technical data



MPG planetary geared motors

Technical data



Gearboxes

MPG planetary-geared motors

19 ... 359 Nm (asynchronous servo motors)

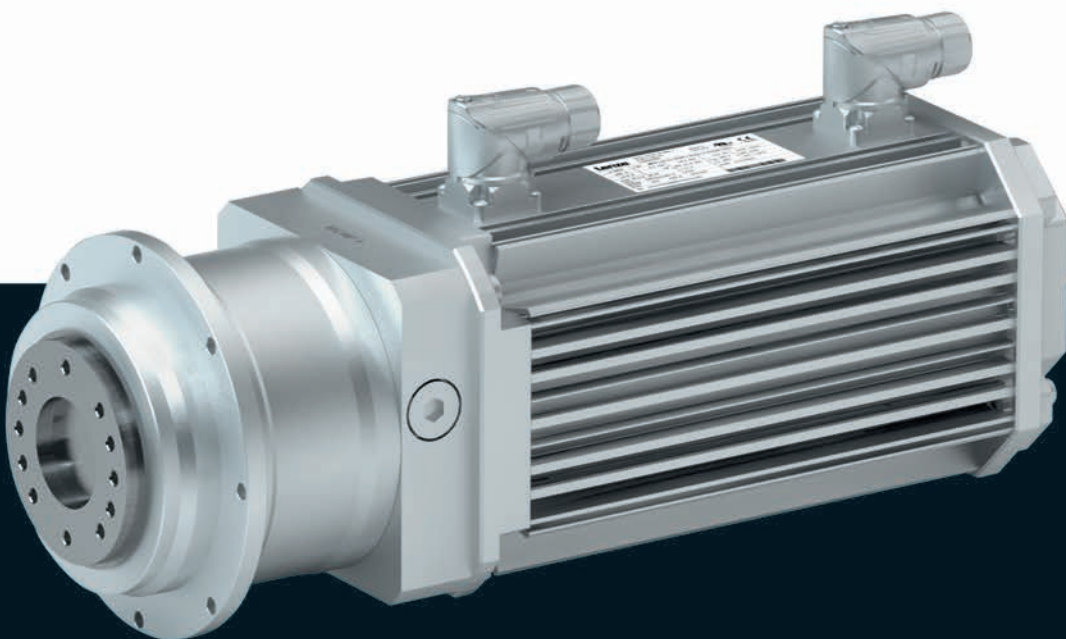

MPG planetary geared motors



Contents

General information	List of abbreviations	6.2.5 - 5
	Product information	6.2.5 - 6
	Equipment	6.2.5 - 7
	The gearbox kit	6.2.5 - 9
	Dimensioning	6.2.5 - 14
Technical data	Selection tables, notes	6.2.5 - 17
	Selection tables	6.2.5 - 18
	Dimensions, notes	6.2.5 - 22
	Dimensions, self-ventilated motors	6.2.5 - 23
	Dimensions, forced ventilated motors	6.2.5 - 30
	Weights, self-ventilated motors	6.2.5 - 35
	Weights, forced ventilated motors	6.2.5 - 35
	Surface and corrosion protection	6.2.5 - 36

MPG planetary geared motors

Contents

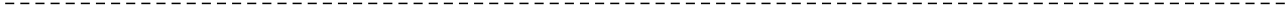

MPG planetary geared motors

General information



List of abbreviations

c		Load capacity
i		Ratio
J	[kgcm ²]	Moment of inertia
m	[kg]	Mass
M ₂	[Nm]	Output torque
M _{2, max}	[Nm]	Max. output torque
n _{2, eto}	[r/min]	Transition speed
n _{2, th}	[r/min]	Thermal limit speed

CCC	China Compulsory Certificate
CE	Communauté Européenne
CSA	Canadian Standards Association
cURus	Combined certification marks of UL for the USA and Canada
DIN	Deutsches Institut für Normung e.V.
EMC	Electromagnetic compatibility
EN	European standard
GOST	Certificate for Russian Federation
IEC	International Electrotechnical Commission
IM	International Mounting Code
IP	International Protection Code
NEMA	National Electrical Manufacturers Association
UL	Underwriters Laboratory Listed Product
UR	Underwriters Laboratory Recognized Product
VDE	Verband deutscher Elektrotechniker (Association of German Electrical Engineers)

MPG planetary geared motors



General information

Product information

The combination of Vogel MPR/MPG planetary gearboxes and Lenze servo motors is the optimum solution for dynamic or highly dynamic applications requiring the highest precision. These solutions cater to the requirements such as those encountered on a daily basis in the printing and packaging industry, as well as in the fields of handling and robot technology, filling and materials handling technology and, in many cases, also general engineering.

The MPR/MPG planetary gearboxes feature a higher-than-average torsional stiffness combined with a backlash down to one angular minute. Their combination with MCS synchronous servo motors and MCA asynchronous servo motors creates flexible and particularly energy-efficient solutions which cover virtually every application.

Version

- Robust planetary gearbox with solid shaft (MPR) or flanged shaft (MPG)
- High precision for the application thanks to low backlash (min. ≤ 1 angular minutes)
- Efficient drive solutions with high efficiency (95 ... 97 %)
- Any mounting position which can be changed subsequently as well
- Enclosure IP65 (dust-tight, protection against water jets under any angle)

The product name

Gearbox type	Product range	Rated torque [Nm]	Product
Planetary gearbox	MPG	29	MPG050
		83	MPG100
		200	MPG200
		390	MPG300

MPG planetary geared motors

General information



Equipment

Overview

The equipment includes all the options available as standard and all the built-on accessories of the product.

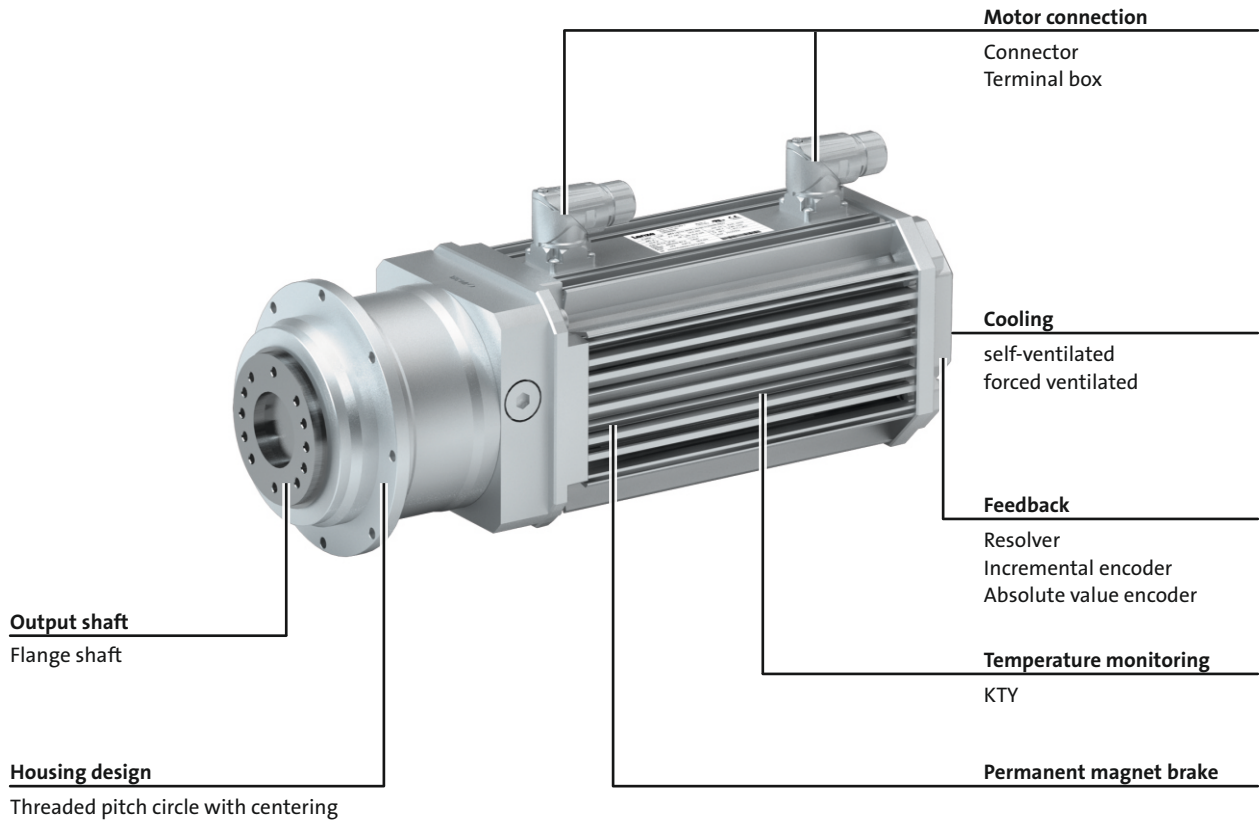

MPG planetary geared motors

General information



MPG planetary geared motors

General information



The gearbox kit

Geared motor

Product	MPG050	MPG100	MPG200	MPG300
Motor type	Asynchronous servo motor			
Servo motor				
2.0 Nm	MCA10			
4.0 - 6.3 Nm		MCA13		
5.4 - 12 Nm			MCA14	
9.5 - 21 Nm			MCA17	
12 - 36 Nm				MCA19
17 - 61 Nm				
Technical data				
Output torque	See selection table			
Output speed	See selection table			
Ratio	See selection table			
Load capacity	See selection table			
Moment of inertia	See selection table			
Mounting position				
Standard	Any			
Colour				
	primed (RAL 9005M, matt jet black)			
Surface and corrosion protection				
	Without OKS(uncoated) OKS-G (primed)			

MPG planetary geared motors

General information



The gearbox kit

Motor details

Product	MCA					
	10I40	13I34 13I41	14L16 14L20 14L35 14L41	17N17 17N23 17N35 17N41	19S17 19S23 19S35 19S42	21X17 21X25 21X35 21X42
Connection type	Plug connectors Terminal box					
Permanent magnet holding brake						
Rated torque [Nm]	3.3	12	15	24	46	88
Brake voltage [V]	DC 24 AC 230					
Feedback	With absolute value encoder With incremental encoder With resolver					
Cooling	Self-ventilated	Self-ventilated Forced-ventilated				
Temperature monitoring	KTY83-110 thermal detector					
Approval	cURus GOST_R UkrSepro					
Degree of protection	IP54 IP65					

- Further information and installation feasibilities can be found in the Motors chapter.









MPG planetary geared motors

General information

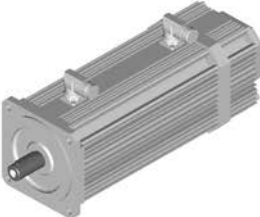

The gearbox kit

Motor details

Connection type		
 Plug connectors	 Terminal box	
Cooling: self-ventilated		
 With resolver	 With permanent magnet brake	 With feedback With feedback and permanent magnet brake
Cooling: forced ventilated		
 With resolver	 With permanent magnet brake	 With feedback With feedback and permanent magnet brake

6.2.5

MPG planetary geared motors

General information



The gearbox kit

Gearbox details

Product	MPG050	MPG100	MPG200	MPG300
Driven shaft				
Flange shaft with threaded holes	40	63	80	100
Design	Standard			
Gasket	NBR			
Bearing	Standard			
Housing				
Housing version	Without foot with centering			
Output flange				
flange diameter [mm]	86	118	145	179
Lubricant				
Type	Mobil SHC 629			
Breather element	Without			
Backlash				
Backlash	Standard Reduced			

- Further information and installation feasibilities can be found in the Gearboxes chapter.

MPG planetary geared motors

General information



The gearbox kit

Gearbox details

Flange shaft



With centering

MPG planetary geared motors



General information

Dimensioning

General information about the data provided in this catalogue

The powers, torques and speeds specified in this catalogue are rounded values and are valid under the following conditions:

- Operating time/day = 8 h (100% OT)
- Duty class I for up to 10 switching operations/h
- Mounting positions and designs in this catalogue
- Standard lubricant
- $T_{amb} = 30\text{ °C}$ for gearboxes,
 $T_{amb} = 40\text{ °C}$ for motors (in accordance with EN 60034)
- Site altitude $< = 1000\text{ m amsl}$
- The selection tables provide the permissible mechanical powers and torques. For notes on the thermal power limit, see chapter drive dimensioning.
- The rated power specified for motors and geared motors applies to operating mode S1 (in accordance with EN 60034).

Under different operating conditions, the values obtained may vary from those listed here.

In the case of extreme operating conditions, please consult your Lenze sales office.

MPG planetary geared motors



General information

Dimensioning

Load capacity and application factor

Load capacity c of gearbox

Rated value for the load capacity of Lenze geared motors.

- c is the ratio of the permissible rated torque of the gearbox to the rated torque supplied by the drive component (e.g. the built-in Lenze motor).
- The value of c must always be greater than the value of the application factor k calculated for the application.

Application factor k (according to DIN 3990)

Takes into account the influence of temporally variable loads which are actually present during the anticipated operating time of gearboxes and geared motors.

k is determined by:

- the type of load
- the load intensity
- temporal influences

Duty class	Load type
I	Smooth operation, small or light jolts
II	Uneven operation, average jolts
III	Uneven operation, severe jolts and/or alternating load

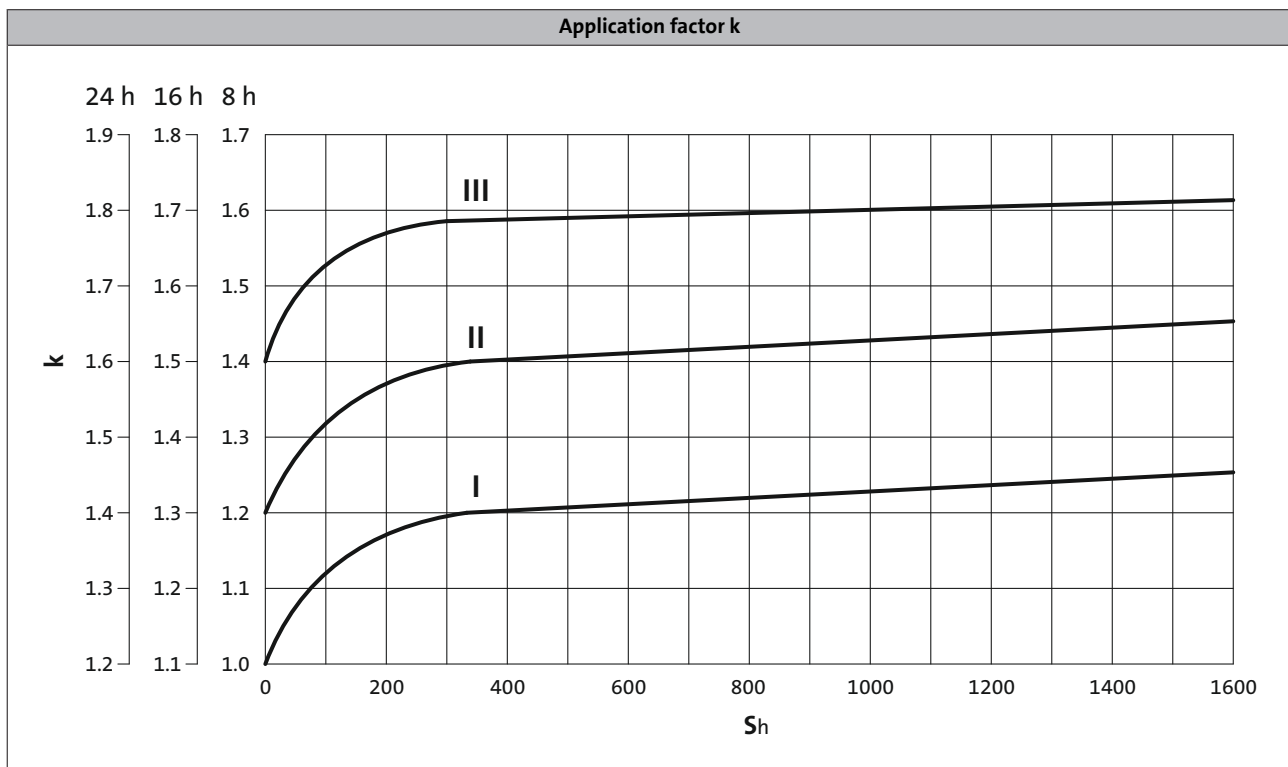

► S_h = switchings/h

MPG planetary geared motors



General information

Dimensioning

Weights

The values given in the tables consider the following gearbox/motor combination:

- Gearbox with solid shaft including lubricant amount
- Motor with feedback

For versions deviating from this, additional weights have to be considered.

The respective values can be found for:

- Geared motors with feedback
 - > Chapter: Geared motors/Technical data
- Motor options: Brake
 - > Chapter: Motors/Accessories

Moments of inertia

The given moments of inertia of the gearbox refer to the drive shaft. The influence of the ratio (i^2) has been considered in the data.

When the total moment of inertia of the geared motor is calculated, the values of the geared motors and the brake have to be added.

The respective values can be found for:

- Geared motors with feedback
 - > Chapter: Geared motors/Technical data/Selection tables
- Motor options: Brake
 - > Chapter: Motors/Accessories

MPG planetary geared motors



Technical data

Selection tables, notes

Notes on the selection tables

The selection tables show the available combinations of gearbox type, number of stages, ratio and motor. They are used only to provide basic orientation.

The following legend indicates the structure of the selection tables.

Number of the gear stage of the gearbox



2-stage gearboxes

Inverter operation						i	Product		Cooling	
M _{2, max} [Nm]	n _{2, th} [r/min]	M ₂ [Nm]	n _{2, eto} [r/min]	c	J [kgcm ²]		MPG	MCS		
29	275	7	275	3.9	0.300	16.000	050	06C60	Selbst	39
29	275	14	275	2.1	0.400	16.000	050	06F60	Selbst	39
29	275	18	275	1.6	0.500	16.000	050	06I60	Selbst	39
29	275	27	275	1.1	1.300	16.000	050	09D60	Selbst	39

For operating mode S1
Torque M₂ and
thermal output speed n_{2, th}

For operating mode S2, S3 und S6
Max. permissible acceleration torque of geared
motor M_{2, max} and
output speed n_{2, eto}

Moment of inertia of
geared motor

Ratio i

Product
Gearbox

Product
Motor

Type of
motor cooling

Page number
for dimensions

Load capacity of the gearbox
c is the ratio between the permissible rated torque of the
gearbox and the rated torque of the three-phase AC
motor (converted to the driven shaft).
c must be always higher than the service factor k
determined for the application k.

$$c = \frac{M_{2, zul}}{M_{1N} \cdot i \cdot \eta_{Getr}} > k$$

MPG planetary geared motors



Technical data

Selection tables

1-stage gearboxes

Inverter operation						i	Product		Cooling	
M _{2, max} [Nm]	n _{2, th} [r/min]	M ₂ [Nm]	n _{2, eto} [r/min]	c	J [kgcm ²]		MPG	MCA		
19	395	19	395	1.0	2.600	10.000	050	10I40	natural	23
29	825	8	825	3.9	2.700	4.000	050	10I40	natural	23
29	660	9	660	3.1	2.600	5.000	050	10I40	natural	23
29	529	13	529	2.2	2.600	7.000	050	10I40	natural	23
58	310	19	310	3.1	2.900	10.000	100	10I40	natural	24
58	310	39	310	1.5	8.900	10.000	100	13I41	natural	24
83	700	16	700	5.3	9.300	4.000	100	13I41	natural	24
83	700	24	700	3.5	9.300	4.000	100	13I34	forced	30
83	560	19	560	4.3	9.200	5.000	100	13I41	natural	24
83	560	30	560	2.8	9.200	5.000	100	13I34	forced	30
83	400	27	400	3.0	9.000	7.000	100	13I41	natural	24
83	400	42	400	2.0	9.000	7.000	100	13I34	forced	30
135	280	39	280	3.5	11.000	10.000	200	13I41	natural	26
135	280	52	280	2.6	22.000	10.000	200	14L41	natural	26
135	280	60	280	2.3	11.000	10.000	200	13I34	forced	31
135	280	92	280	1.5	39.000	10.000	200	17N41	natural	26
135	280	105	280	1.3	22.000	10.000	200	14L35	forced	31
135	230	105	230	1.3	39.000	10.000	200	17N23	natural	26
135	200	65	200	2.1	22.000	10.000	200	14L20	natural	26
135	164	119	164	1.1	22.000	10.000	200	14L16	forced	31
190	400	36	400	5.2	22.000	7.000	200	14L41	natural	26
190	400	42	400	4.5	11.000	7.000	200	13I34	forced	31
190	400	65	400	2.9	39.000	7.000	200	17N41	natural	26
190	400	73	400	2.6	22.000	7.000	200	14L35	forced	31
190	400	129	400	1.5	39.000	7.000	200	17N35	forced	31
190	329	73	329	2.6	39.000	7.000	200	17N23	natural	26
190	286	45	286	4.2	22.000	7.000	200	14L20	natural	26
190	240	147	240	1.3	39.000	7.000	200	17N17	forced	31
190	234	83	234	2.3	22.000	7.000	200	14L16	forced	31
195	500	46	500	4.2	39.000	5.000	200	17N41	natural	26
195	500	52	500	3.7	23.000	5.000	200	14L35	forced	31
195	500	92	500	2.1	39.000	5.000	200	17N35	forced	31
195	460	52	460	3.7	39.000	5.000	200	17N23	natural	26
195	336	105	336	1.9	39.000	5.000	200	17N17	forced	31
195	327	59	327	3.3	23.000	5.000	200	14L16	forced	31
200	625	37	625	5.4	40.000	4.000	200	17N41	natural	26
200	625	42	625	4.8	23.000	4.000	200	14L35	forced	31
200	625	73	625	2.7	40.000	4.000	200	17N35	forced	31
200	575	42	575	4.8	40.000	4.000	200	17N23	natural	26
200	420	84	420	2.4	40.000	4.000	200	17N17	forced	31

6.2.5

MPG planetary geared motors

Technical data



Selection tables

1-stage gearboxes

Inverter operation						i	Product		Cooling	
M _{2, max} [Nm]	n _{2, th} [r/min]	M ₂ [Nm]	n _{2, eto} [r/min]	c	J [kgcm ²]		MPG	MCA		
200	409	48	409	4.2	23.000	4.000	200	14L16	forced	31
245	260	52	260	4.7	26.000	10.000	300	14L41	natural	28
245	260	92	260	2.6	43.000	10.000	300	17N41	natural	28
245	260	105	260	2.3	26.000	10.000	300	14L35	forced	33
245	260	116	260	2.1	80.000	10.000	300	19S42	natural	28
245	260	184	260	1.3	43.000	10.000	300	17N35	forced	33
245	234	158	234	1.6	80.000	10.000	300	19S23	natural	28
245	230	105	230	2.3	43.000	10.000	300	17N23	natural	28
245	200	65	200	3.8	26.000	10.000	300	14L20	natural	28
245	168	210	168	1.2	43.000	10.000	300	17N17	forced	33
245	164	119	164	2.1	26.000	10.000	300	14L16	forced	33
380	329	65	329	5.9	44.000	7.000	300	17N41	natural	28
380	329	73	329	5.2	44.000	7.000	300	17N23	natural	28
380	329	73	329	5.2	27.000	7.000	300	14L35	forced	33
380	329	81	329	4.7	81.000	7.000	300	19S42	natural	28
380	329	111	329	3.4	81.000	7.000	300	19S23	natural	28
380	329	129	329	3.0	44.000	7.000	300	17N35	forced	33
380	329	244	329	1.6	81.000	7.000	300	19S35	forced	33
380	243	244	243	1.6	81.000	7.000	300	19S17	forced	33
380	240	147	240	2.6	44.000	7.000	300	17N17	forced	33
380	234	83	234	4.6	27.000	7.000	300	14L16	forced	33
388	525	73	525	5.3	47.000	4.000	300	17N35	forced	33
388	420	84	420	4.7	47.000	4.000	300	17N17	forced	33
390	525	139	525	2.8	83.000	4.000	300	19S35	forced	33
390	425	139	425	2.8	83.000	4.000	300	19S17	forced	33
390	420	79	420	4.9	83.000	5.000	300	19S23	natural	28
390	420	92	420	4.3	45.000	5.000	300	17N35	forced	33
390	420	174	420	2.2	83.000	5.000	300	19S35	forced	33
390	340	174	340	2.2	83.000	5.000	300	19S17	forced	33
390	336	105	336	3.7	45.000	5.000	300	17N17	forced	33

6.2.5

MPG planetary geared motors



Technical data

Selection tables

2-stage gearboxes

Inverter operation						i	Product		Cooling	
M _{2, max} [Nm]	n _{2, th} [r/min]	M ₂ [Nm]	n _{2, eto} [r/min]	c	J [kgcm ²]		MPG	MCA		
76	88	73	88	1.0	2.600	40.000	100	10I40	natural	25
83	219	29	219	2.8	2.700	16.000	100	10I40	natural	25
83	175	37	175	2.3	2.600	20.000	100	10I40	natural	25
83	140	46	140	1.8	2.600	25.000	100	10I40	natural	25
83	125	51	125	1.6	2.600	28.000	100	10I40	natural	25
83	100	64	100	1.3	2.600	35.000	100	10I40	natural	25
190	155	37	155	5.3	3.000	20.000	200	10I40	natural	27
190	56	129	56	1.5	2.900	70.000	200	10I40	natural	27
195	155	76	155	2.6	9.100	20.000	200	13I41	natural	27
195	155	117	155	1.7	9.100	20.000	200	13I34	forced	32
195	124	46	124	4.3	3.000	25.000	200	10I40	natural	27
195	124	95	124	2.0	9.100	25.000	200	13I41	natural	27
195	124	146	124	1.3	9.100	25.000	200	13I34	forced	32
195	89	64	89	3.0	2.900	35.000	200	10I40	natural	27
195	89	133	89	1.5	9.000	35.000	200	13I41	natural	27
195	70	92	70	2.1	2.900	50.000	200	10I40	natural	27
195	70	190	70	1.0	8.900	50.000	200	13I41	natural	27
200	194	61	194	3.3	9.200	16.000	200	13I41	natural	27
200	194	94	194	2.1	9.200	16.000	200	13I34	forced	32
200	111	51	111	3.9	2.900	28.000	200	10I40	natural	27
200	111	107	111	1.9	9.000	28.000	200	13I41	natural	27
200	111	164	111	1.2	9.000	28.000	200	13I34	forced	32
200	78	73	78	2.7	2.900	40.000	200	10I40	natural	27
200	78	152	78	1.3	8.900	40.000	200	13I41	natural	27
380	46	267	46	1.4	10.000	70.000	300	13I41	natural	29
380	46	356	46	1.1	22.000	70.000	300	14L41	natural	29
390	181	81	181	4.8	23.000	16.000	300	14L41	natural	29
390	181	94	181	4.2	11.000	16.000	300	13I34	forced	34
390	181	145	181	2.7	40.000	16.000	300	17N41	natural	29
390	181	164	181	2.4	23.000	16.000	300	14L35	forced	34
390	181	288	181	1.4	40.000	16.000	300	17N35	forced	34
390	145	76	145	5.1	11.000	20.000	300	13I41	natural	29
390	145	102	145	3.8	22.000	20.000	300	14L41	natural	29
390	145	117	145	3.3	11.000	20.000	300	13I34	forced	34
390	145	181	145	2.1	39.000	20.000	300	17N41	natural	29
390	145	205	145	1.9	22.000	20.000	300	14L35	forced	34
390	145	360	145	1.1	39.000	20.000	300	17N35	forced	34
390	144	164	144	2.4	40.000	16.000	300	17N23	natural	29
390	125	102	125	3.8	23.000	16.000	300	14L20	natural	29
390	116	95	116	4.1	11.000	25.000	300	13I41	natural	29

6.2.5

MPG planetary geared motors

Technical data



Selection tables

2-stage gearboxes

Inverter operation						i	Product		Cooling	
M _{2, max} [Nm]	n _{2, th} [r/min]	M ₂ [Nm]	n _{2, eto} [r/min]	c	J [kgcm ²]		MPG	MCA		
390	116	127	116	3.1	22.000	25.000	300	14L41	natural	29
390	116	146	116	2.7	11.000	25.000	300	13I34	forced	34
390	116	226	116	1.7	39.000	25.000	300	17N41	natural	29
390	116	256	116	1.5	22.000	25.000	300	14L35	forced	34
390	115	205	115	1.9	39.000	20.000	300	17N23	natural	29
390	105	328	105	1.2	40.000	16.000	300	17N17	forced	34
390	104	107	104	3.7	11.000	28.000	300	13I41	natural	29
390	104	142	104	2.7	22.000	28.000	300	14L41	natural	29
390	104	164	104	2.4	11.000	28.000	300	13I34	forced	34
390	104	253	104	1.5	39.000	28.000	300	17N41	natural	29
390	104	287	104	1.4	22.000	28.000	300	14L35	forced	34
390	102	186	102	2.1	23.000	16.000	300	14L16	forced	34
390	100	127	100	3.1	22.000	20.000	300	14L20	natural	29
390	92	256	92	1.5	39.000	25.000	300	17N23	natural	29
390	83	133	83	2.9	11.000	35.000	300	13I41	natural	29
390	83	178	83	2.2	22.000	35.000	300	14L41	natural	29
390	83	205	83	1.9	11.000	35.000	300	13I34	forced	34
390	83	317	83	1.2	39.000	35.000	300	17N41	natural	29
390	83	358	83	1.1	22.000	35.000	300	14L35	forced	34
390	82	233	82	1.7	22.000	20.000	300	14L16	forced	34
390	82	287	82	1.4	39.000	28.000	300	17N23	natural	29
390	80	159	80	2.5	22.000	25.000	300	14L20	natural	29
390	73	152	73	2.6	11.000	40.000	300	13I41	natural	29
390	73	204	73	1.9	22.000	40.000	300	14L41	natural	29
390	73	234	73	1.7	11.000	40.000	300	13I34	forced	34
390	73	362	73	1.1	39.000	40.000	300	17N41	natural	29
390	71	178	71	2.2	22.000	28.000	300	14L20	natural	29
390	66	359	66	1.1	39.000	35.000	300	17N23	natural	29
390	65	291	65	1.3	22.000	25.000	300	14L16	forced	34
390	64	190	64	2.0	11.000	50.000	300	13I41	natural	29
390	64	293	64	1.3	11.000	50.000	300	13I34	forced	34
390	58	254	58	1.5	22.000	50.000	300	14L41	natural	29
390	58	326	58	1.2	22.000	28.000	300	14L16	forced	34
390	57	222	57	1.8	22.000	35.000	300	14L20	natural	29
390	50	254	50	1.5	22.000	40.000	300	14L20	natural	29
390	40	318	40	1.2	22.000	50.000	300	14L20	natural	29

6.2.5

MPG planetary geared motors

Technical data



Dimensions, notes

Notes on the dimensions

The following legend shows the layout of the dimension sheets.

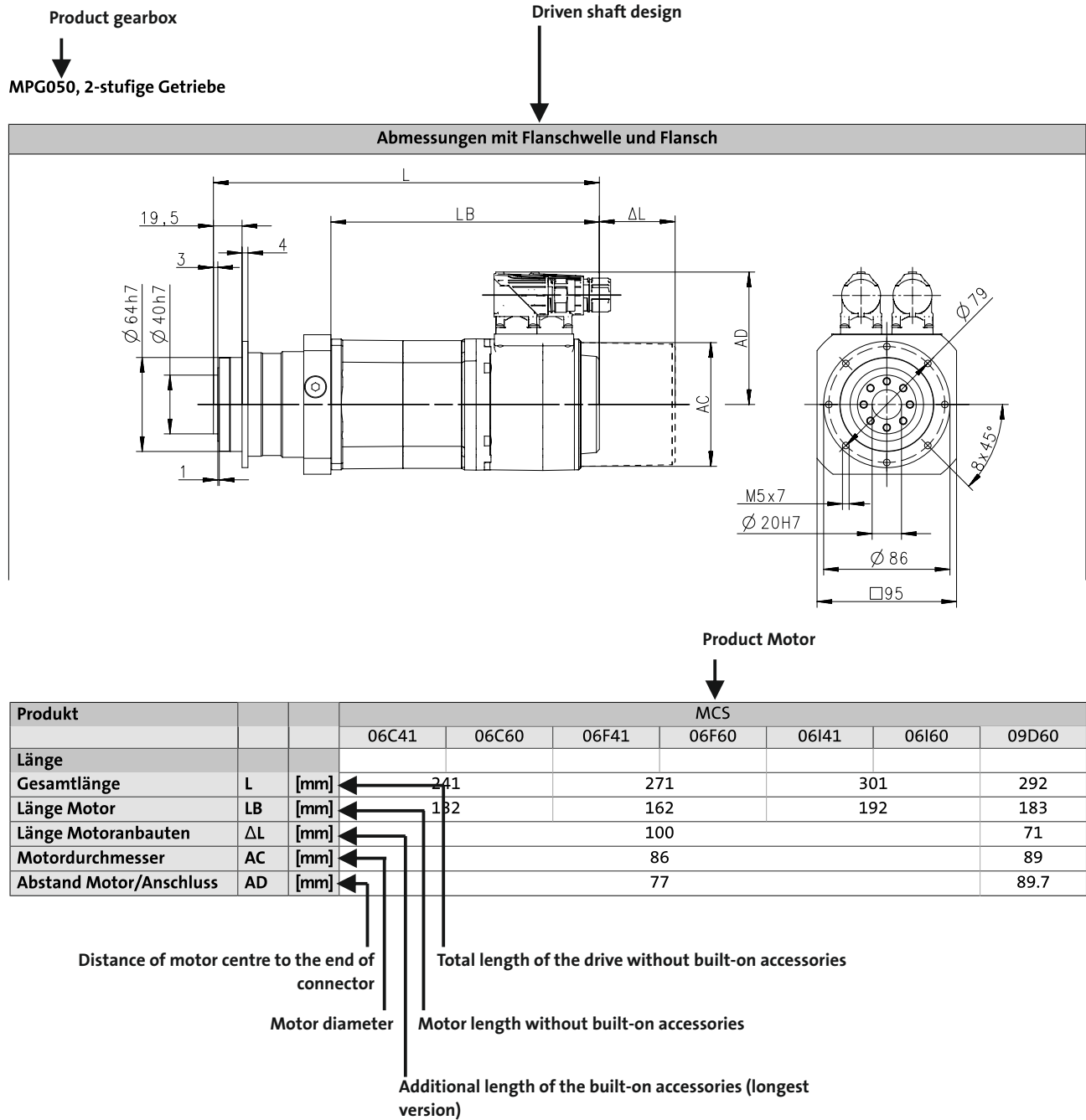

6.2.5

MPG planetary geared motors

Technical data



Dimensions, self-ventilated motors

MPG050, 1-stage gearboxes

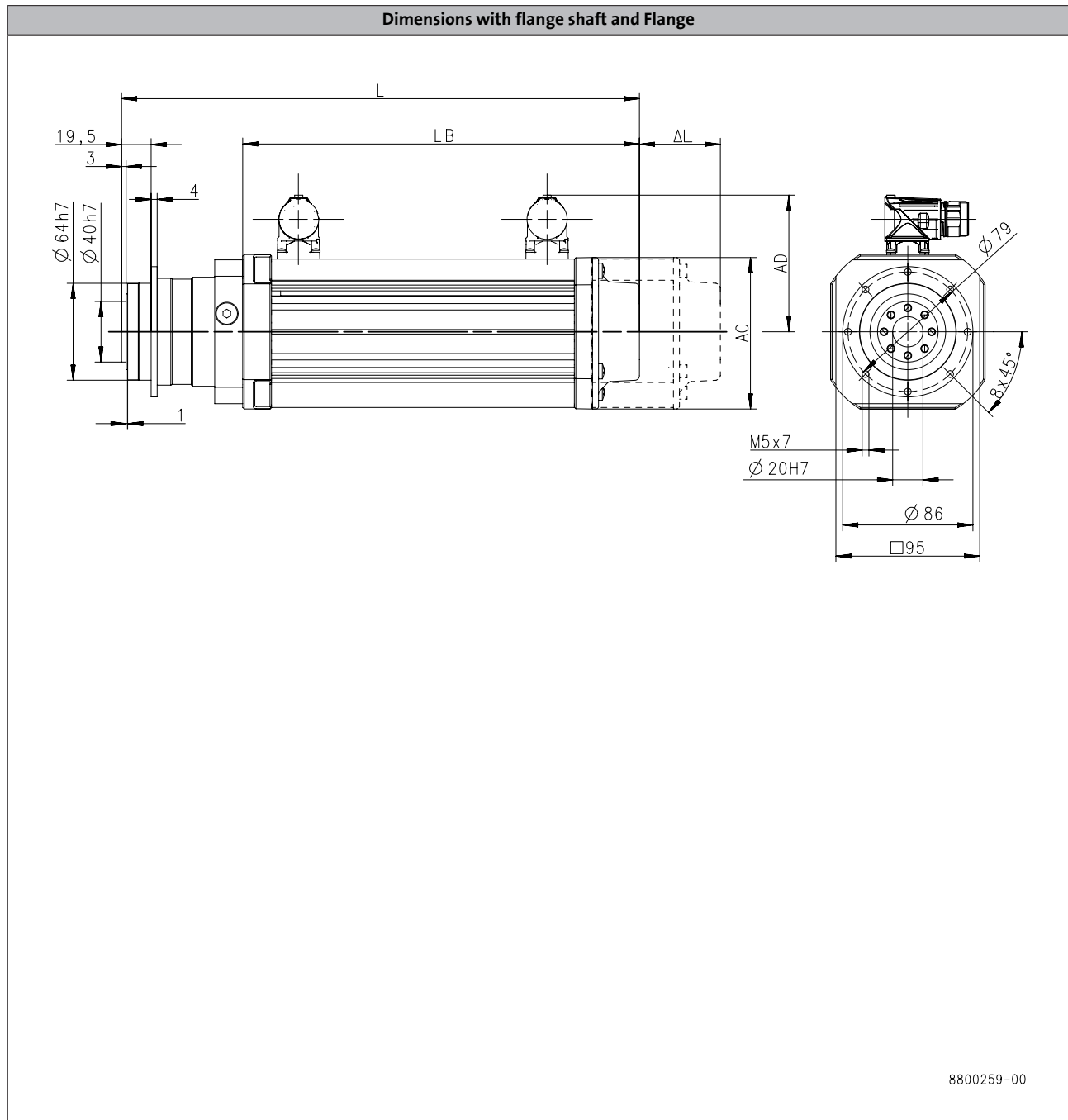

6.2.5

Product			MCA
			10I40
Length			
Total length	L	[mm]	342
Motor length	LB	[mm]	262
Length of motor options	Δ L	[mm]	78.5
Motor diameter	AC	[mm]	102
Distance motor/connection	AD	[mm]	90

MPG planetary geared motors

Technical data



Dimensions, self-ventilated motors

MPG100, 1-stage gearboxes

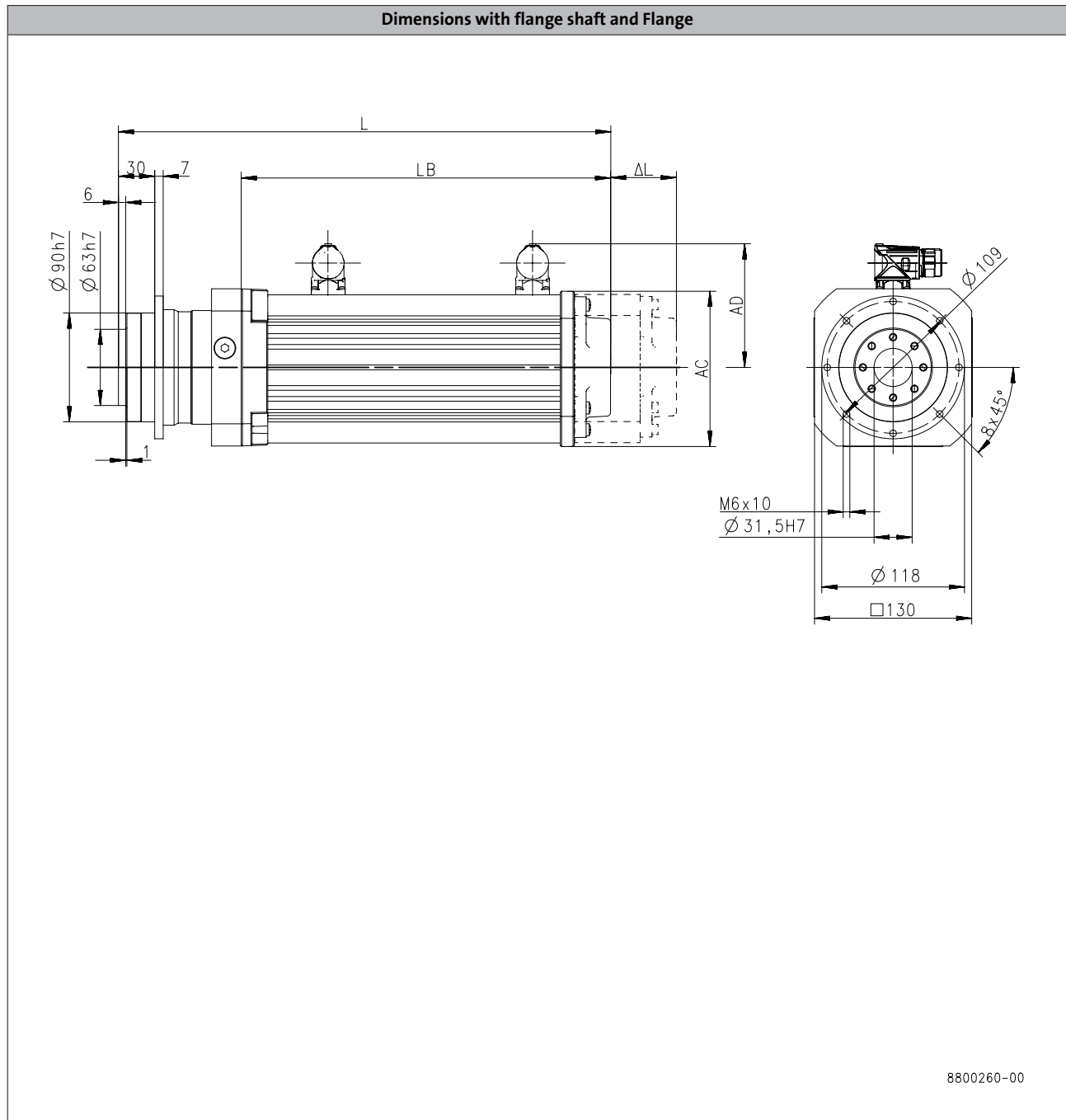

Product			MCA	
			10I40	13I41
Length				
Total length	L	[mm]	364	372
Motor length	LB	[mm]	262	270.5
Length of motor options	Δ L	[mm]	78.5	89
Motor diameter	AC	[mm]	102	130
Distance motor/connection	AD	[mm]	90	102

MPG planetary geared motors

Technical data



Dimensions, self-ventilated motors

MPG100, 2-stage gearboxes

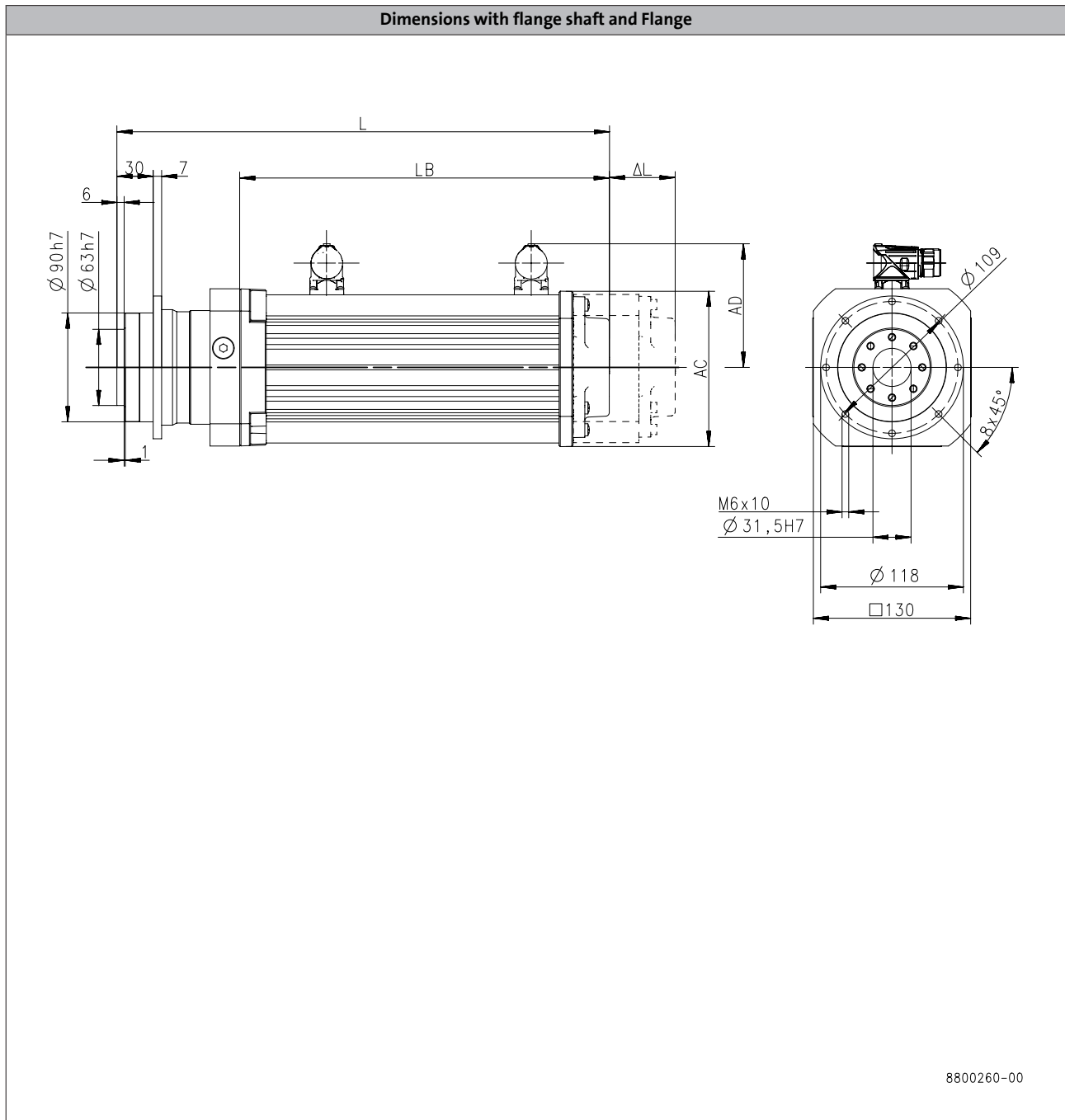

6.2.5

Product			MCA
			10I40
Length			
Total length	L	[mm]	384
Motor length	LB	[mm]	262
Length of motor options	Δ L	[mm]	78.5
Motor diameter	AC	[mm]	102
Distance motor/connection	AD	[mm]	90

MPG planetary geared motors

Technical data



Dimensions, self-ventilated motors

MPG200, 1-stage gearboxes

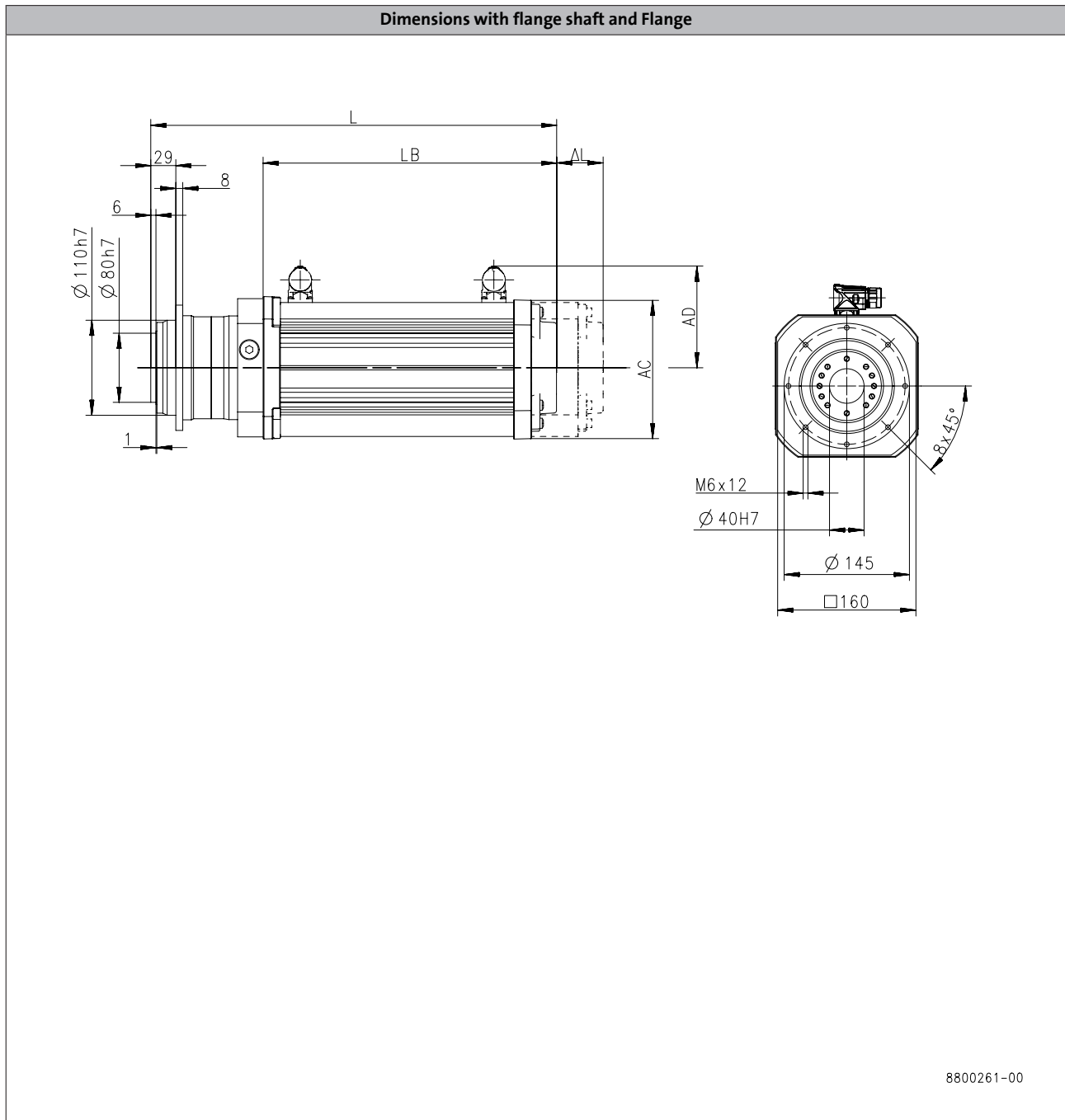

Product	MCA						
			13I41	14L20	14L41	17N23	17N41
Length							
Total length	L	[mm]	401		432		470
Motor length	LB	[mm]	270.5		301.5		339.5
Length of motor options	ΔL	[mm]	89		88.5		89.2
Motor diameter	AC	[mm]	130		142		165
Distance motor/connection	AD	[mm]	102		109		117.5

MPG planetary geared motors

Technical data



Dimensions, self-ventilated motors

MPG200, 2-stage gearboxes

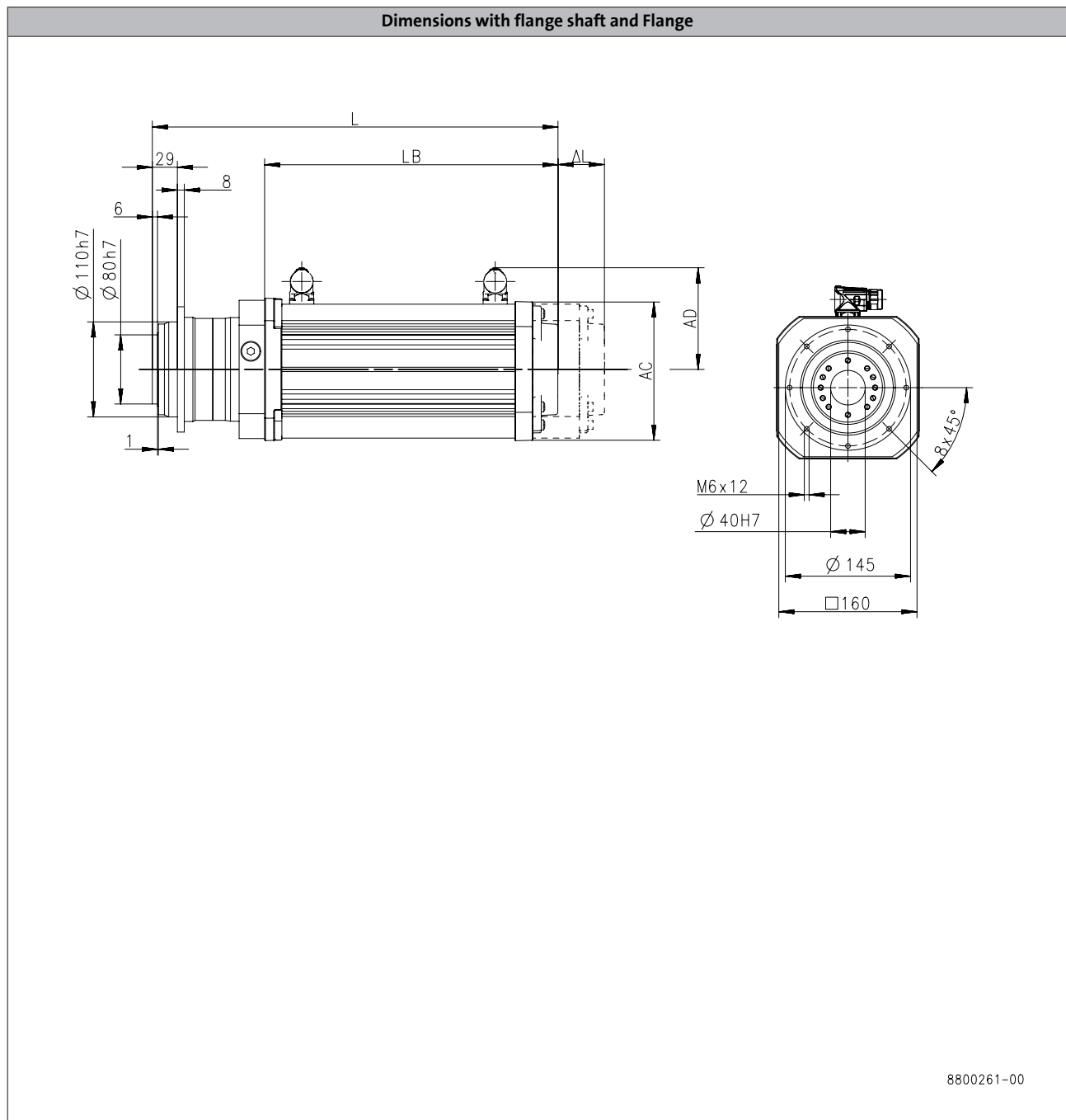

6.2.5

Product			MCA	
			10I40	13I41
Length				
Total length	L	[mm]	406	415
Motor length	LB	[mm]	262	270.5
Length of motor options	Δ L	[mm]	78.5	89
Motor diameter	AC	[mm]	102	130
Distance motor/connection	AD	[mm]	90	102

MPG planetary geared motors

Technical data



Dimensions, self-ventilated motors

MPG300, 1-stage gearboxes

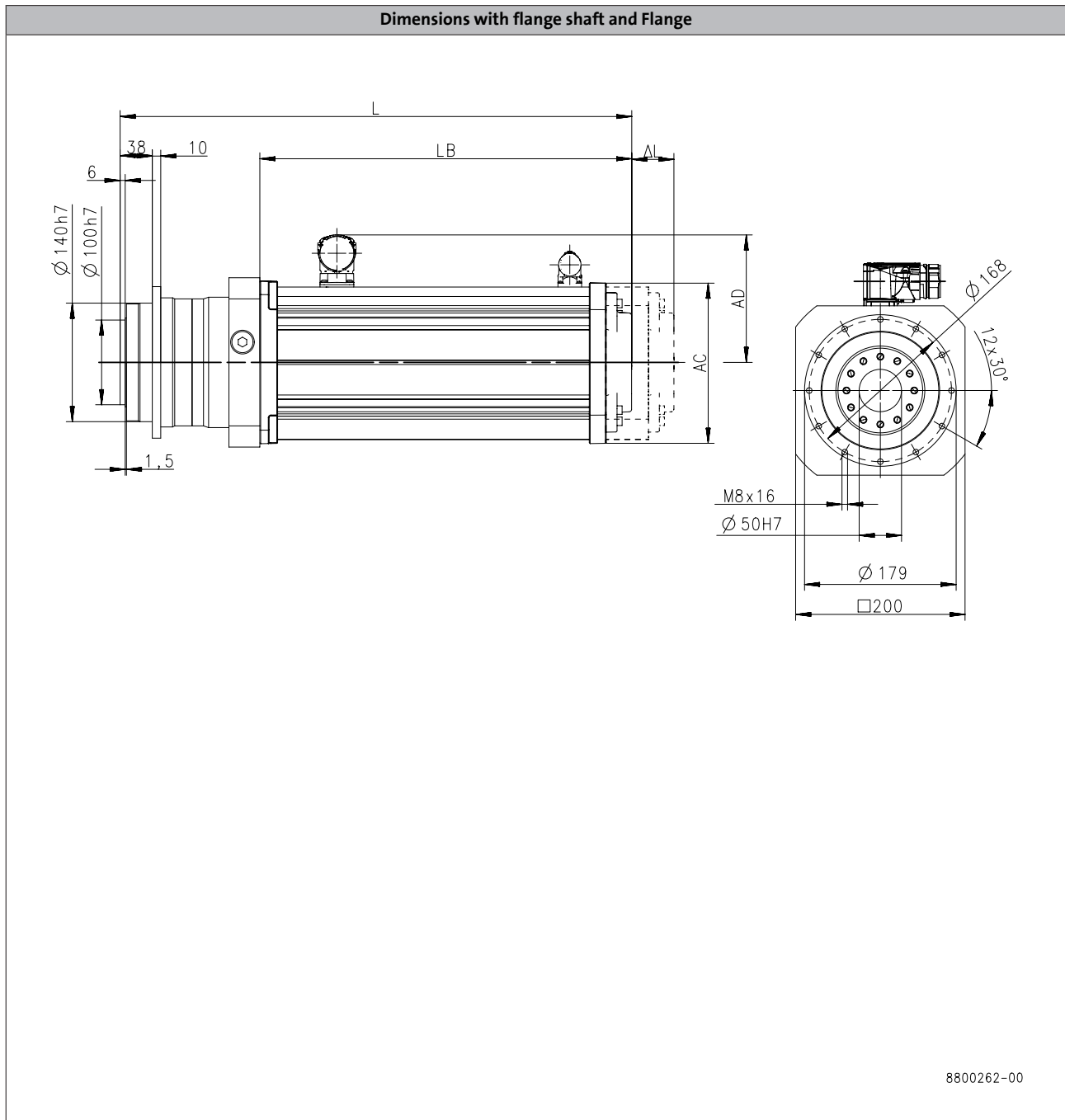

6.2.5

Product			MCA					
			14L20	14L41	17N23	17N41	19S23	19S42
Length								
Total length	L	[mm]	467		505		566	
Motor length	LB	[mm]	301.5		339.5		401	
Length of motor options	ΔL	[mm]	88.5		89.2		88.2	
Motor diameter	AC	[mm]	142		165		192	
Distance motor/connection	AD	[mm]	109		117.5		151	

MPG planetary geared motors

Technical data



Dimensions, self-ventilated motors

MPG300, 2-stage gearboxes

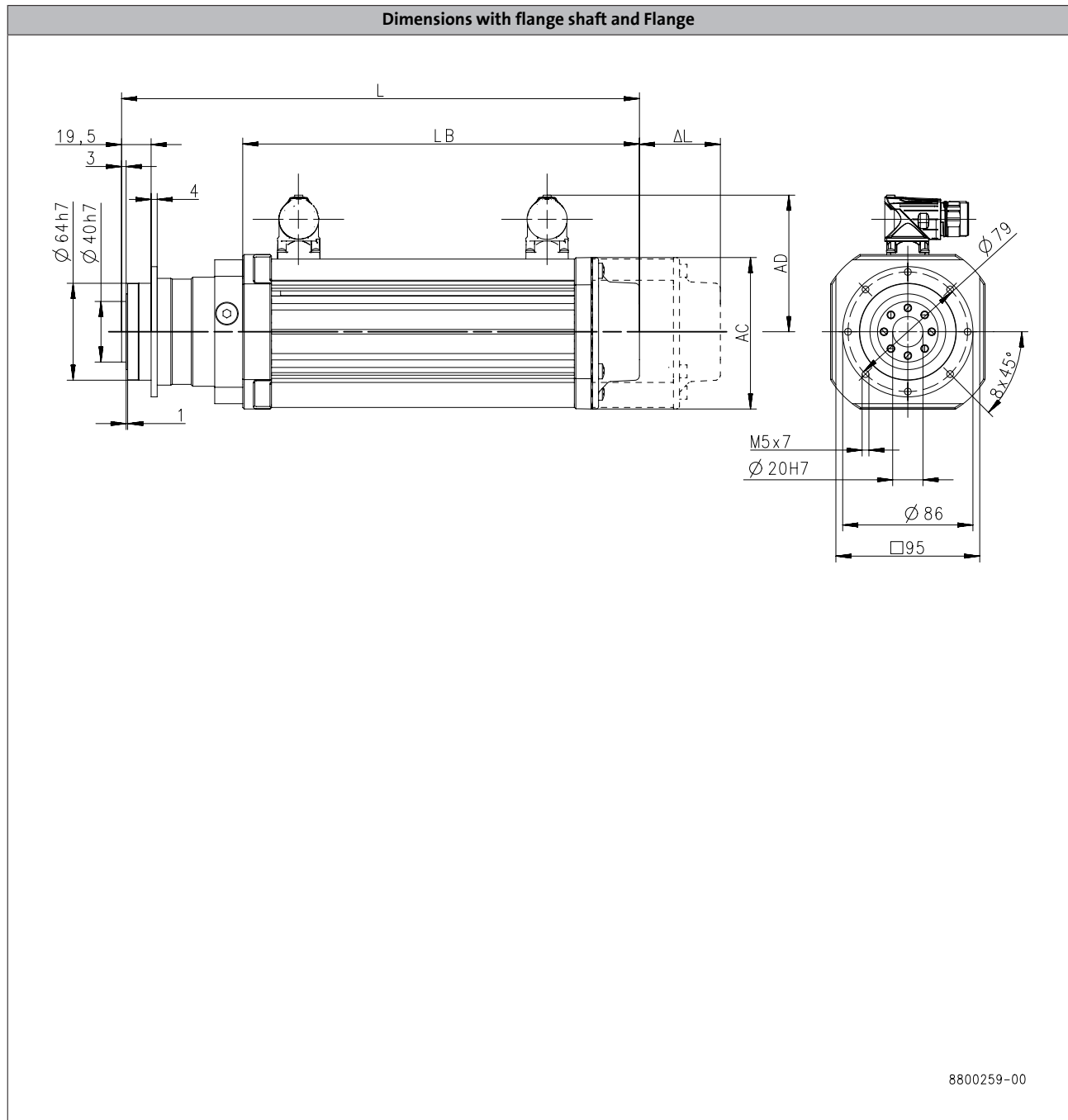

6.2.5

Product			MCA				
			13I41	14L20	14L41	17N23	17N41
Length							
Total length	L	[mm]	454		485		523
Motor length	LB	[mm]	270.5		301.5		339.5
Length of motor options	Δ L	[mm]	89		88.5		89.2
Motor diameter	AC	[mm]	130		142		165
Distance motor/connection	AD	[mm]	102		109		117.5

MPG planetary geared motors

Technical data



Dimensions, forced ventilated motors

MPG100, 1-stage gearboxes

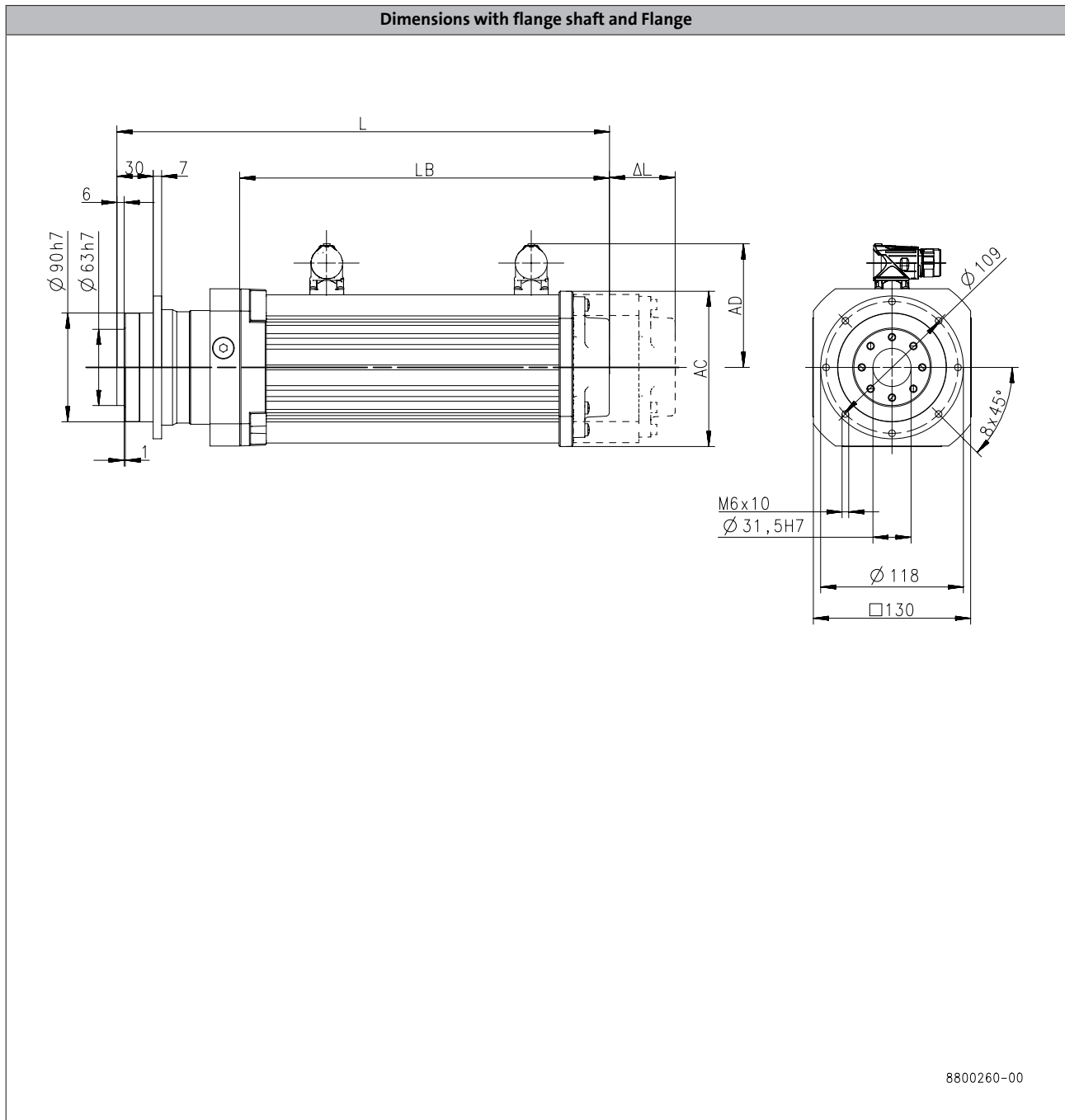

Product			MCA
			13I34
Length			
Total length	L	[mm]	440
Motor length	LB	[mm]	338.5
Length of motor options	Δ L	[mm]	89.5
Motor diameter	AC	[mm]	130
Distance motor/connection	AD	[mm]	102

MPG planetary geared motors

Technical data



Dimensions, forced ventilated motors

MPG200, 1-stage gearboxes

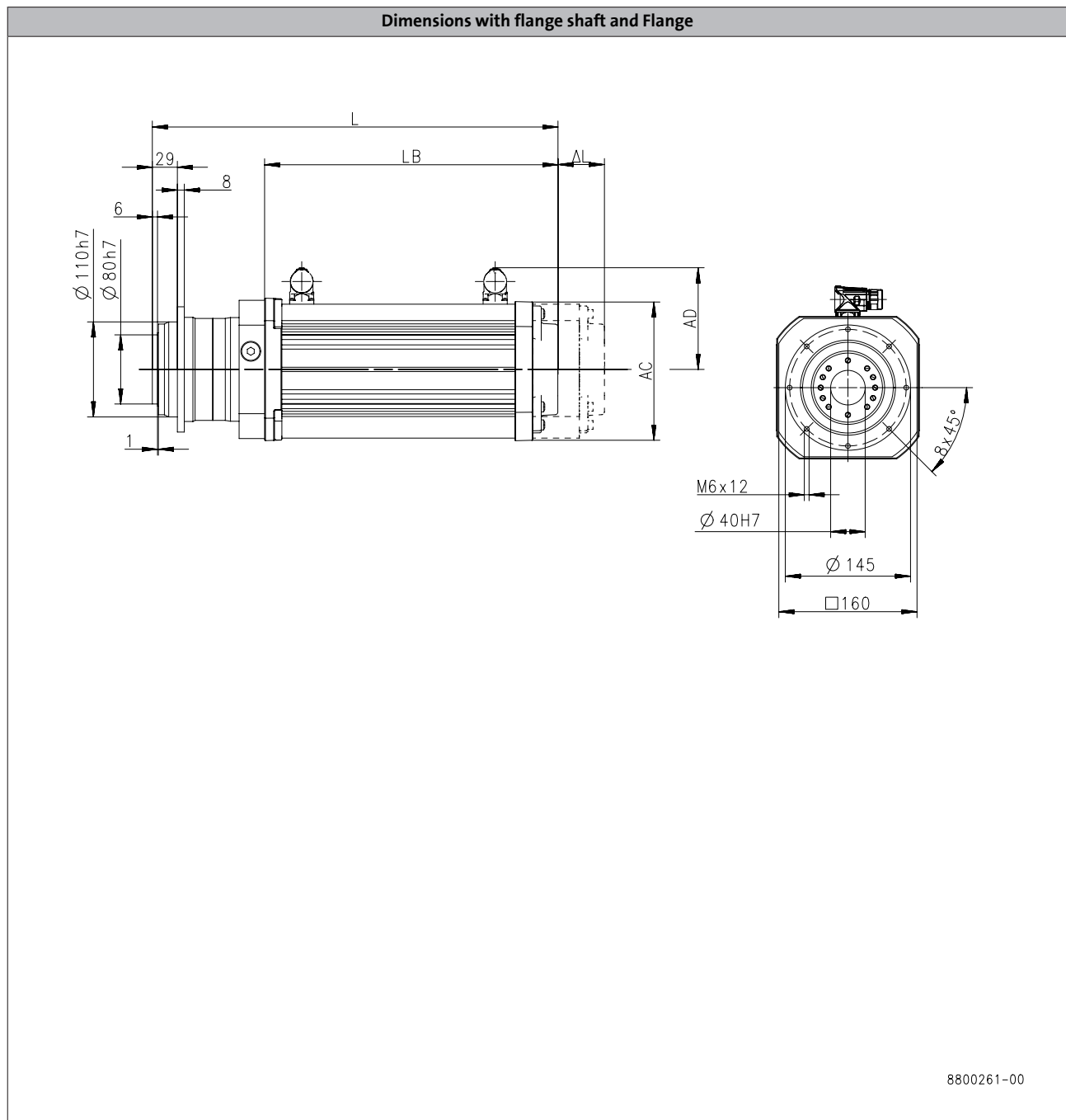

6.2.5

Product	MCA						
			13I34	14L16	14L35	17N17	17N35
Length							
Total length	L	[mm]	469	494		556	
Motor length	LB	[mm]	338.5	363.5		425.5	
Length of motor options	ΔL	[mm]	89.5	88.5		89	
Motor diameter	AC	[mm]	130	142		165	
Distance motor/connection	AD	[mm]	102	109		117.5	

MPG planetary geared motors

Technical data



Dimensions, forced ventilated motors

MPG200, 2-stage gearboxes

Dimensions with flange shaft and Flange

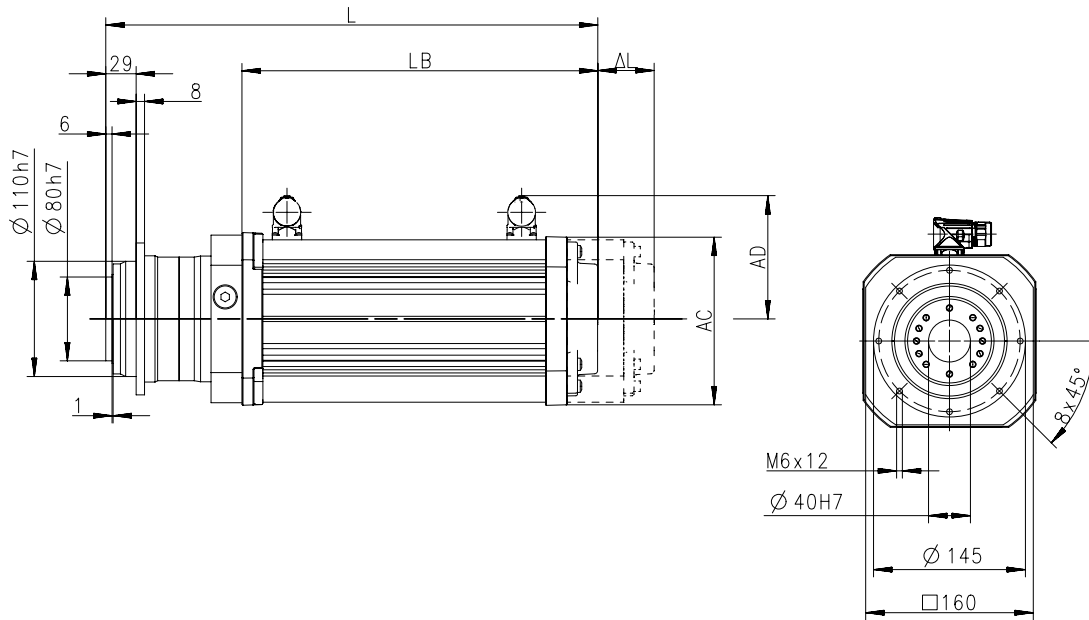

8800261-00

Product			MCA
			13I34
Length			
Total length	L	[mm]	483
Motor length	LB	[mm]	338.5
Length of motor options	Δ L	[mm]	89.5
Motor diameter	AC	[mm]	130
Distance motor/connection	AD	[mm]	102

MPG planetary geared motors

Technical data



Dimensions, forced ventilated motors

MPG300, 1-stage gearboxes

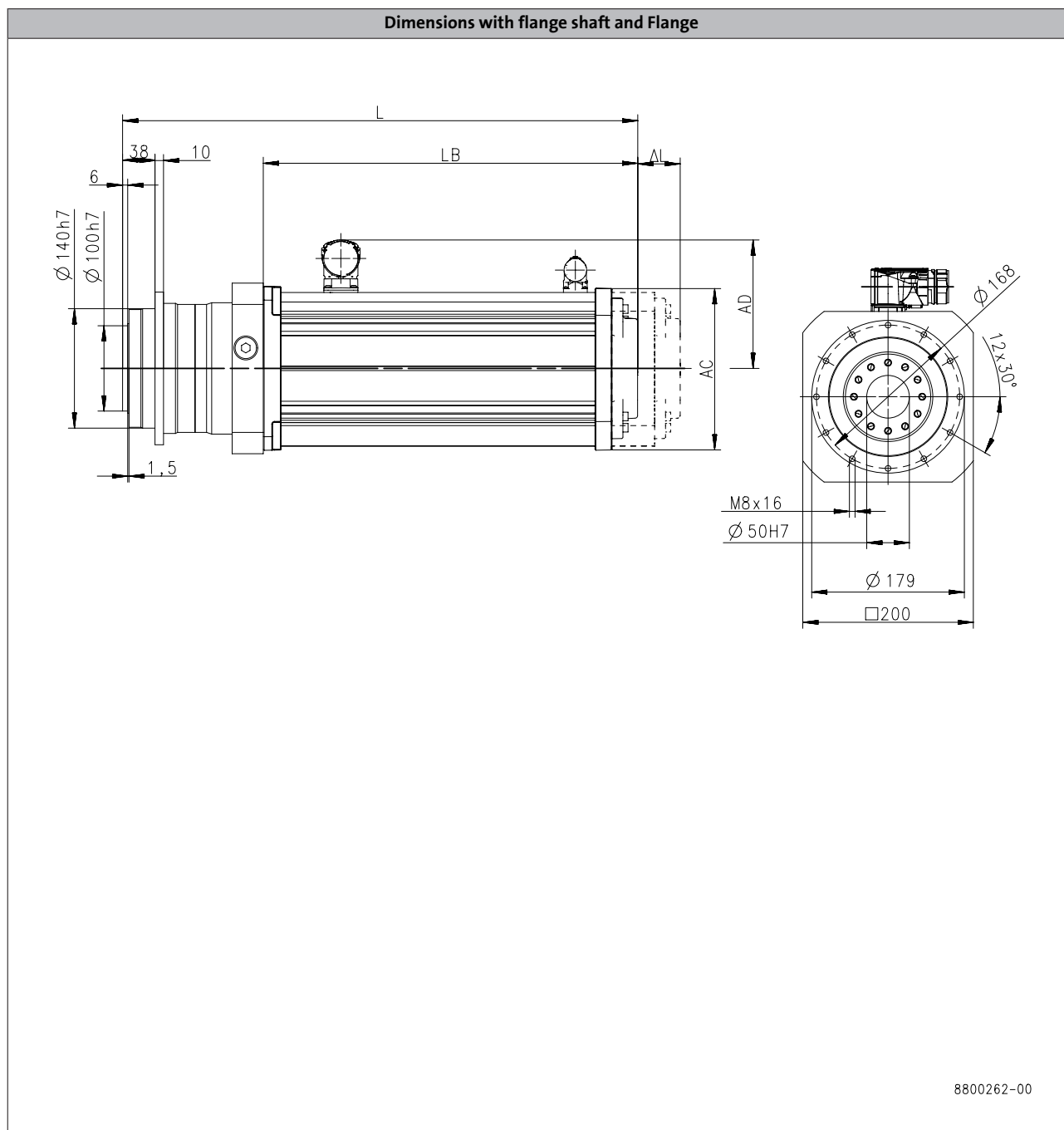

6.2.5

Product			MCA					
			14L16	14L35	17N17	17N35	19S17	19S35
Length								
Total length	L	[mm]	529		591		663	
Motor length	LB	[mm]	363.5		425.5		498	
Length of motor options	ΔL	[mm]	88.5		89		88.2	
Motor diameter	AC	[mm]	142		165		192	
Distance motor/connection	AD	[mm]	109		117.5		151	

MPG planetary geared motors

Technical data



Dimensions, forced ventilated motors

MPG300, 2-stage gearboxes

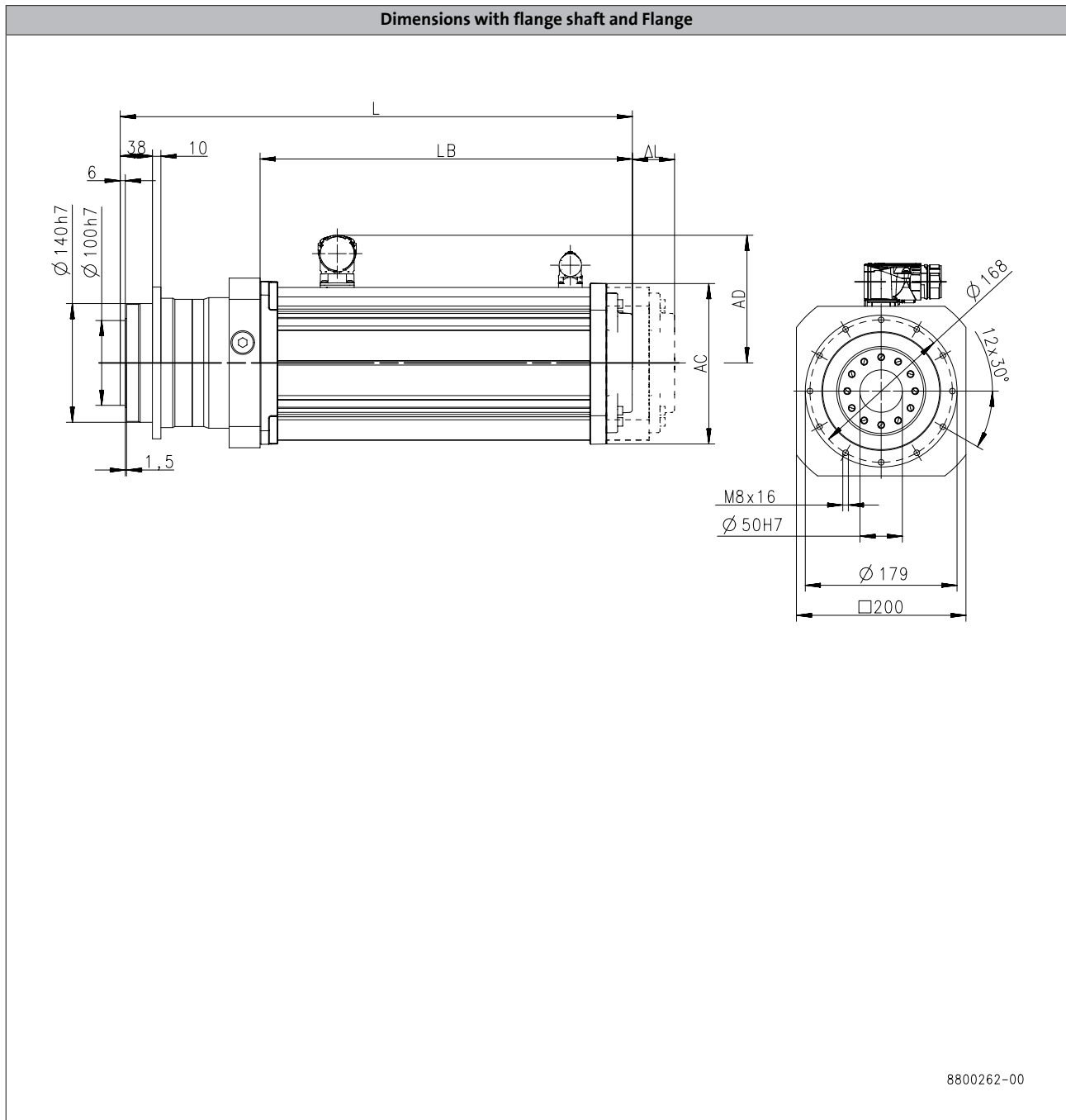

Product			MCA				
			13I34	14L16	14L35	17N17	17N35
Length							
Total length	L	[mm]	522	547		609	
Motor length	LB	[mm]	338.5	363.5		425.5	
Length of motor options	Δ L	[mm]	89.5	88.5		89	
Motor diameter	AC	[mm]	130	142		165	
Distance motor/connection	AD	[mm]	102	109		117.5	

MPG planetary geared motors

Technical data



Weights, self-ventilated motors

1-stage gearboxes

				MCA				
				10I40	13I41	14L20 14L41	17N23 17N41	19S23 19S42
MPG	050	m	[kg]	7.9				
	100	m	[kg]	10	14			
	200	m	[kg]		17	22	30	
	300	m	[kg]			29	36	58

2-stage gearboxes

				MCA			
				10I40	13I41	14L20 14L41	17N23 17N41
MPG	100	m	[kg]	11			
	200	m	[kg]	13	17		
	300	m	[kg]		25	30	37

Weights, forced ventilated motors

1-stage gearboxes

				MCA			
				13I34	14L16 14L35	17N17 17N35	19S17 19S35
MPG	100	m	[kg]	16			
	200	m	[kg]	19	24	32	
	300	m	[kg]		30	39	62

2-stage gearboxes

				MCA		
				13I34	14L16 14L35	17N17 17N35
MPG	200	m	[kg]	19		
	300	m	[kg]	26	31	40

MPG planetary geared motors

Technical data



Surface and corrosion protection

For optimum protection of geared motors against ambient conditions, the surface and corrosion protection system (OKS) offers tailor-made solutions.

Various surface coatings combined with other protective measures ensure that the geared motors operate reliably even at high air humidity, in outdoor installations or in the presence of atmospheric impurities. Any colour from the RAL Classic collection can be chosen for the top coat. The geared motors are also available unpainted (no surface and corrosion protection).

Surface and corrosion protection	Applications	Measures
OKS-G (primed)	<ul style="list-style-type: none"> • Dependent on subsequent top coat applied 	<ul style="list-style-type: none"> • 2K PUR priming coat (grey) • Zinc-coated screws • Rust-free breather elements Optional measures <ul style="list-style-type: none"> • Stainless steel nameplate

Structure of surface coating

Surface and corrosion protection	Surface coating
	Structure
Without OKS(uncoated)	Dipping primed gearbox
OKS-G (primed)	Dipping primed gearbox 2K PUR priming coat

Gearboxes

MPG planetary gearbox

29 to 390 Nm

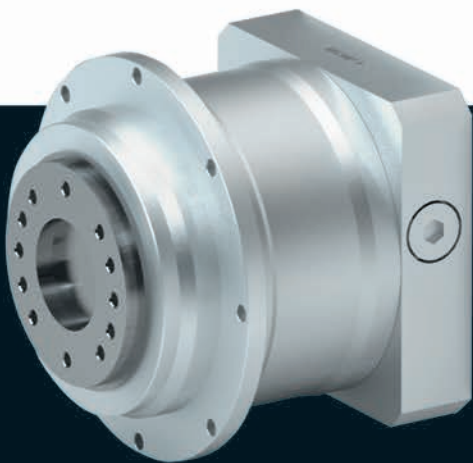

MPG planetary gearboxes

Contents



General information	List of abbreviations	6.2.6 - 5
	Product information	6.2.6 - 6
	Equipment	6.2.6 - 7
	The gearbox kit	6.2.6 - 8
	Functions and features	6.2.6 - 10
Technical data	Permissible radial and axial forces at output	6.2.6 - 11
	Backlash and torsional rigidity	6.2.6 - 12
	Speeds and torques	6.2.6 - 13
	Moments of inertia	6.2.6 - 15

MPG planetary gearboxes

Contents



MPG planetary gearboxes

General information



List of abbreviations

$F_{ax,max}$	[N]	Max. axial force
$F_{rad,max}$	[N]	Max. radial force
i		Ratio
J	[kgcm ²]	Moment of inertia
m	[kg]	Mass

MPG planetary gearboxes

General information



Product information

The MPR/MPG planetary gearboxes feature a higher-than-average torsional stiffness combined with a backlash down to one angular minute. Their combination with MCS synchronous servo motors and MCA asynchronous servo motors creates flexible and particularly energy-efficient solutions which cover virtually every application.

Version

- Robust planetary gearbox with solid shaft (MPR) or flanged shaft (MPG)
- High precision for the application thanks to low backlash (min. ≤ 1 angular minutes)
- Efficient drive solutions with high efficiency (95 ... 97 %)
- Any mounting position which can be changed subsequently as well
- Enclosure IP65 (dust-tight, protection against water jets under any angle)

The product name

Gearbox type	Product range	Rated torque [Nm]	Product
Planetary gearbox	MPG	29	MPG050
		83	MPG100
		200	MPG200
		390	MPG300

MPG planetary gearboxes

General information



Equipment

Overview

The equipment includes all the options available as standard and all the built-on accessories of the product.

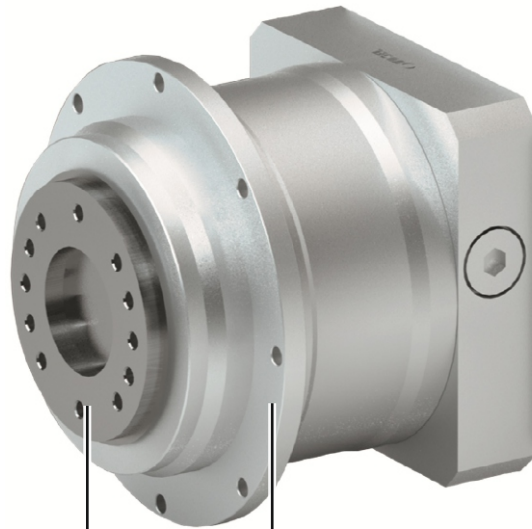

Output shaft
Flange shaft

Housing design
Flange with through holes

MPG planetary gearboxes

General information



The gearbox kit

Gearbox details

Product	MPG050	MPG100	MPG200	MPG300
Driven shaft				
Flange shaft with threaded holes	40	63	80	100
Design	Standard			
Gasket	NBR			
Bearing	Standard			
Housing				
Housing version	Without foot with centering			
Output flange				
flange diameter [mm]	86	118	145	179
Lubricant				
Type	Mobil SHC 629			
Breather element	Without			
Backlash				
Backlash	Standard Reduced			

- Further information and installation feasibilities can be found in the Gearboxes chapter.

MPG planetary gearboxes

General information



The gearbox kit

Gearbox details

Flange shaft



With centering

MPG planetary gearboxes

General information



Functions and features

Product	MPG050	MPG100	MPG200	MPG300
Housing				
Design	Cylindrical shape			
Flange shaft				
Version	With threaded holes			
Tolerance	h7			
Toothed parts				
Design	Helical cut teeth			
Ratios	Mathematically precise			
Shaft-hub joint				
	Force-fit, motor gearbox connected via clamping hub			
Lubricants				
Changing interval	Lubricated for life			
Quantities	Can be installed in any orientation			
Mechanical efficiency				
1-stage gearboxes [$\eta_{c=1}$]				0.97
2-stage gearboxes [$\eta_{c=1}$]				0.95
3-stage gearboxes [$\eta_{c=1}$]				

Direction of rotation

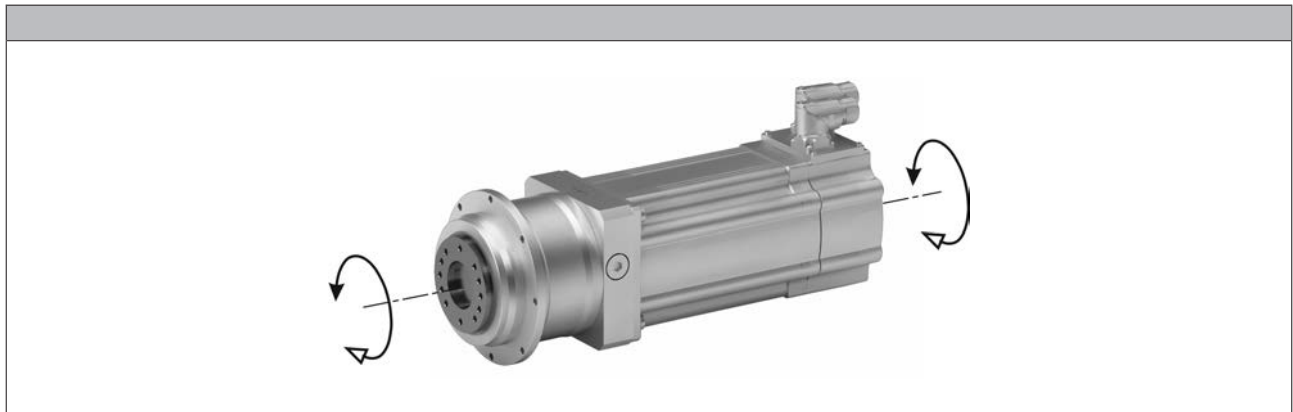

MPG planetary gearboxes

Technical data



Permissible radial and axial forces at output

Permissible axial force

$$F_{ax,per} = F_{ax,max} \text{ if } F_{rad} = 0$$

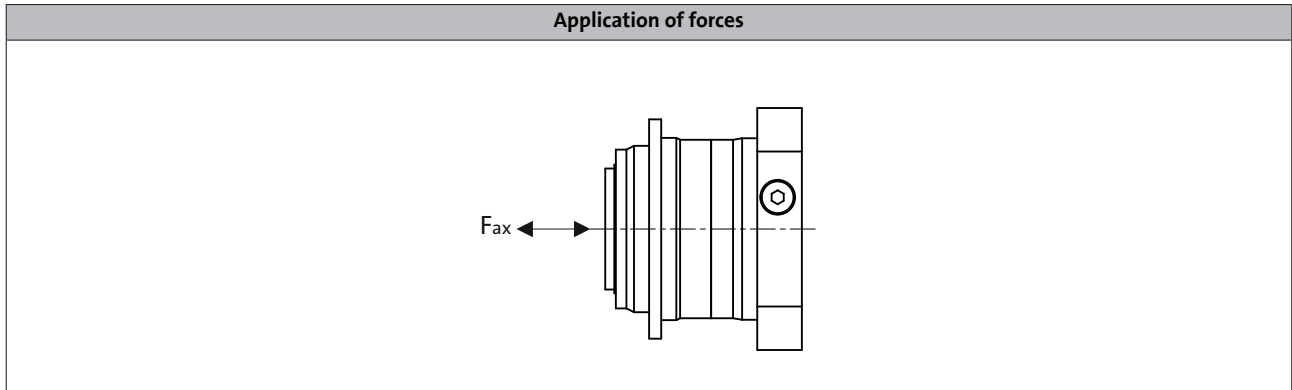

Product	n_2 [r/min]
	250
	$F_{ax,max}$
	[N]
MPG050	2200
MPG100	3600
MPG200	4200
MPG300	8000

MPG planetary gearboxes

Technical data



Backlash and torsional rigidity

1-stage gearboxes

Product	Backlash	
	Standard [arcmin]	Reduced [arcmin]
MPG050	4.00	2.00
MPG100	3.00	1.00
MPG200		
MPG300		

2-stage gearboxes

Product	Backlash	
	Standard [arcmin]	Reduced [arcmin]
MPG050	4.00	2.00
MPG100	3.00	1.00
MPG200		
MPG300		

► Measured at output. Load 2 % of the rated torque value.

MPG planetary gearboxes

Technical data



Speeds and torques

- ▶ **Rated torque $M_{2, GN}$**
At rated speed, ambient temperature 20 °C and duty type S1.
- ▶ **Max. output torque $M_{2, max}$**
Max. 1000 cycles per hour permissible.
- ▶ **Emergency off torque $M_{2, not}$**
Max.1000 emergency switching off actions during gearbox service life
- ▶ **Max. gearbox input speed**
 $n_{1, max 50\%}$
Max. medium speed at 50 % rated torque
 $n_{1, max 100\%}$
Max. medium speed at 100 % rated torque
 $n_{1, max}$
Max. permissible speed

1-stage gearboxes

Product	Ratio i	Rated torque $M_{2, GN}$ [Nm]	Max. output torque $M_{2, max}$ [Nm]	Max. gearbox input speed			Emergency off-torque $M_{2, not}$ [Nm]
				$n_{1, max 50\%}$ [r/min]	$n_{1, max 100\%}$ [r/min]	$n_{1, max}$ [r/min]	
MPG050	4.000	29	44	3300	3300	6000	110
	5.000	29	44	3300	3300		110
	7.000	29	44	3700	3700		107
	10.000	19	35	4000	4000		88
MPG100	4.000	83	120	2800	2800	6000	275
	5.000	83	120	2800	2800		275
	7.000	83	120	2800	2800		275
	10.000	58	90	3100	3100		220
MPG200	4.000	200	330	2500	2500	4500	690
	5.000	195	330	2500	2500		675
	7.000	190	300	2800	2800		640
	10.000	135	235	2800	2800		550
MPG300	4.000	390	660	2100	2100	4000	1400
	5.000	390	660	2100	2100		1400
	7.000	380	600	2300	2300		1400
	10.000	245	480	2600	2600		1100

MPG planetary gearboxes

Technical data



Speeds and torques

2-stage gearboxes

Product	Ratio i	Rated torque $M_{2,GN}$ [Nm]	Max. output torque $M_{2,max}$ [Nm]	Max. gearbox input speed			Emergency off-torque $M_{2,not}$ [Nm]
				$n_{1,max 50\%}$	$n_{1,max 100\%}$	$n_{1,max}$	
				[r/min]	[r/min]	[r/min]	
MPG050	16.000	29	44	4400	4400	6000	110
	20.000	29	44	4400	4400		110
	25.000	29	44	4400	4400		110
	28.000	29	44	4400	4400		110
	35.000	29	44	4400	4400		110
	40.000	29	44	4400	4400		110
	50.000	29	44	4800	4800		110
	70.000	29	44	5500	5500		107
	100.000	19	35	5500	5500		88
MPG100	16.000	83	120	3500	3500	6000	275
	20.000	83	120	3500	3500		275
	25.000	83	120	3500	3500		275
	28.000	83	120	3500	3500		275
	35.000	83	120	3500	3500		275
	40.000	76	120	3500	3500		275
	50.000	83	120	3800	3800		275
	70.000	83	120	4500	4500		275
	100.000	58	90	4500	4500		220
MPG200	16.000	200	330	3100	3100	4500	690
	20.000	195	330	3100	3100		675
	25.000	195	330	3100	3100		675
	28.000	200	330	3100	3100		690
	35.000	195	330	3100	3100		675
	40.000	200	330	3100	3100		690
	50.000	195	330	3500	3500		675
	70.000	190	330	4200	4200		640
	100.000	135	235	4200	4200		550
MPG300	16.000	390	660	2900	2900	4000	1400
	20.000	390	660	2900	2900		1400
	25.000	390	660	2900	2900		1400
	28.000	390	660	2900	2900		1400
	35.000	390	660	2900	2900		1400
	40.000	390	660	2900	2900		1400
	50.000	390	660	3200	3200		1400
	70.000	380	600	3200	3200		1400
	100.000	245	480	3900	3900		1100

MPG planetary gearboxes

Technical data



Moments of inertia

- ▶ The moments of inertia relate to the drive shaft of the gearbox.
- ▶ The total moment of inertia is calculated by adding the values of the gearbox, motor and accessories.

1-stage gearboxes

Product	Dimensions	Ratio	Moment of inertia
	Motor shaft diameter		
	d	i	J
	[mm]		[kgcm ²]
MPG050	11	4.000	0.240
	11	5.000	0.200
	11	7.000	0.180
	11	10.000	0.160
	14	4.000	0.270
	14	5.000	0.230
	14	7.000	0.210
	14	10.000	0.190
	19	4.000	0.440
	19	5.000	0.400
MPG100	14	4.000	0.900
	14	5.000	0.720
	14	7.000	0.570
	14	10.000	0.500
	19	4.000	1.040
	19	5.000	0.870
	19	7.000	0.720
	19	10.000	0.640
	24	4.000	1.750
	24	5.000	1.570
	24	7.000	1.420
	24	10.000	1.350

Product	Dimensions	Ratio	Moment of inertia
	Motor shaft diameter		
	d	i	J
	[mm]		[kgcm ²]
MPG200	19	4.000	3.480
	19	5.000	2.940
	19	7.000	2.500
	19	10.000	2.270
	24	4.000	4.000
	24	5.000	3.460
	24	7.000	3.020
	24	10.000	2.790
	28	4.000	5.810
	28	5.000	5.270
MPG300	24	4.000	10.810
	24	5.000	8.980
	24	7.000	7.500
	24	10.000	6.700
	28	4.000	12.580
	28	5.000	10.750
	28	7.000	9.260
	28	10.000	8.460

MPG planetary gearboxes

Technical data



Moments of inertia

2-stage gearboxes

Product	Dimensions	Ratio	Moment of inertia
	Motor shaft diameter		
	d	i	J
	[mm]		[kgcm ²]
MPG050	11	16.000	0.210
	11	20.000	0.180
	11	25.000	0.180
	11	28.000	0.170
	11	35.000	0.170
	11	40.000	0.160
	11	50.000	0.160
	11	70.000	0.160
	11	100.000	0.160
	14	16.000	0.240
	14	20.000	0.210
	14	25.000	0.210
	14	28.000	0.200
	14	35.000	0.200
MPG100	11	16.000	0.240
	11	20.000	0.200
	11	25.000	0.190
	11	28.000	0.170
	11	35.000	0.170
	11	40.000	0.160
	11	50.000	0.160
	11	70.000	0.160
	11	100.000	0.160
	14	16.000	0.270
	14	20.000	0.230
	14	25.000	0.220
	14	28.000	0.210
	14	35.000	0.200
MPG200	14	16.000	0.780
	14	20.000	0.620
	14	25.000	0.600
	14	28.000	0.520
	14	35.000	0.510
	14	40.000	0.470
	14	50.000	0.470
	14	70.000	0.460
	14	100.000	0.460
	19	16.000	0.920
	19	20.000	0.770
	19	25.000	0.750
	19	28.000	0.670
	19	35.000	0.660
19	40.000	0.620	
19	50.000	0.610	
19	70.000	0.610	
19	100.000	0.600	

Product	Dimensions	Ratio	Moment of inertia
	Motor shaft diameter		
	d	i	J
	[mm]		[kgcm ²]
MPG300	19	16.000	3.190
	19	20.000	2.750
	19	25.000	2.680
	19	28.000	2.410
	19	35.000	2.370
	19	40.000	2.230
	19	50.000	2.210
	19	70.000	2.190
	19	100.000	2.190
	24	16.000	3.710
	24	20.000	3.280
	24	25.000	3.200
	24	28.000	2.930
	24	35.000	2.890
MPG300	24	40.000	2.740
	24	50.000	2.720
	24	70.000	2.710
	24	100.000	2.700
	28	16.000	5.520
	28	20.000	5.080
	28	25.000	5.010
	28	28.000	4.720
	28	35.000	4.690
	28	40.000	4.540
	28	50.000	4.520
	28	70.000	4.510
	28	100.000	4.500

6.2.6

Motors

MCS synchronous servo motors

0.25 to 190 Nm



MCS synchronous servo motors

Contents



General information	List of abbreviations	6.11 - 4
	Product key	6.11 - 6
	Product information	6.11 - 8
	Functions and features	6.11 - 9
	Dimensioning	6.11 - 10
Technical data	Standards and operating conditions	6.11 - 17
	Permissible radial and axial forces	6.11 - 18
	Rated data, non-ventilated	6.11 - 19
	Rated data, forced ventilated	6.11 - 24
	Selection tables, Servo Drives 9400 HighLine	6.11 - 26
	Selection tables, Inverter Drives 8400 TopLine	6.11 - 36
	Selection tables, Servo Drives ECS	6.11 - 47
	Selection tables, Servo Inverter 9300	6.11 - 56
	Torque characteristics	6.11 - 63
	Dimensions, self-ventilated	6.11 - 100
	Dimensions, forced ventilated	6.11 - 104
	Accessories	Permanent magnet holding brake
Resolver		6.11 - 109
Incremental encoder and SinCos absolute value encoder		6.11 - 110
Blowers		6.11 - 112
Temperature monitoring		6.11 - 113
Terminal box		6.11 - 114
ICN connector	6.11 - 116	

MCS synchronous servo motors

General information



List of abbreviations

$\eta_{100\%}$	[%]	Efficiency
$\cos \varphi$		Power factor
du/dt	[kV/ μ s]	Insulation resistance
$F_{ax,-}$	[N]	Min. axial force
$F_{ax,+}$	[N]	Max. axial force
$f_{in,max}$	[Hz]	Max. input frequency
f_{max}	[kHz]	Limit frequency
f_{max}	[kHz]	Max. switching frequency
f_N	[Hz]	Rated frequency
F_{rad}	[N]	Max. radial force
H_{max}	[m]	Site altitude
I_0	[A]	Standstill current
I_{max}	[A]	Max. short-time DC-bus current
I_{max}	[A]	Max. current
I_{max}	[A]	Max. current consumption
I_{max}	[A]	Max. current
I_{max}	[A]	Max. DC-bus current
I_N	[A]	Rated current
J	[kgcm ²]	Moment of inertia
J_{MB}	[kgcm ²]	Moment of inertia
$KE_{LL\ 150\ ^\circ C}$	[V / 1000 rp]	Voltage constant
$Kt_{0\ 150\ ^\circ C}$	[Nm/A]	Torque constant
L	[mH]	Mutual inductance
$L_{1\sigma}$	[mH]	Stator leakage inductance
$L_{2\sigma}$	[mH]	Rotor leakage inductance
L_N	[mH]	Rated inductance
m	[kg]	Mass
M_0	[Nm]	Stall torque
$M_{0,max}$	[Nm]	Max. standstill torque
M_{av}	[Nm]	Average dynamic torque
M_{max}	[Nm]	Max. torque
M_N	[Nm]	Rated torque
n_{eto}	[r/min]	Transition speed
n_k	[r/min]	Speed
n_{max}	[r/min]	Max. speed

n_N	[r/min]	Rated speed
P_N	[kW]	Rated power
Q_E	[J]	Maximum switching energy
R	[Ω]	Insulation resistance
R	[Ω]	Min. insulation resistance
R_1	[Ω]	Stator impedance
R_2	[Ω]	Charging resistor
R_2	[Ω]	Rotor impedance
$R_{UV\ 150\ ^\circ C}$	[Ω]	Stator impedance
$R_{UV\ 20\ ^\circ C}$	[Ω]	Stator impedance
$S_{h\u00fc}$	[1/h]	Transition operating frequency
T	[$^\circ C$]	Operating temperature
T	[$^\circ C$]	Rated temperature
T	[$^\circ C$]	Max. ambient temperature of bearing
T	[$^\circ C$]	Max. surface temperature
T	[$^\circ C$]	Max. ambient temperature for transport
T	[$^\circ C$]	Min. ambient storage temperature
T	[$^\circ C$]	Min. ambient temperature for transport
T	[$^\circ C$]	Ambient temperature
t_1	[ms]	Engagement time
t_2	[ms]	Disengagement time
$T_{opr,max}$	[$^\circ C$]	Max. ambient operating temperature
$T_{opr,min}$	[$^\circ C$]	Min. ambient operating temperature
$U_{in,max}$	[V]	Max. input voltage
$U_{in,min}$	[V]	Min. input voltage
U_{max}	[V]	Max. mains voltage
U_{max}	[V]	Min. input voltage
U_{min}	[V]	Min. mains voltage
$U_{N, AC}$	[V]	Rated voltage
$U_{N, DC}$	[V]	Rated voltage
Z_{ro}	[Ω]	Rotor impedance
Z_{rs}	[Ω]	Impedance
Z_{so}	[Ω]	Stator impedance

MCS synchronous servo motors

General information



List of abbreviations

CE	Communauté Européenne
CSA	Canadian Standards Association
DIN	Deutsches Institut für Normung e.V.
EMC	Electromagnetic compatibility
EN	European standard
GOST	Certificate for Russian Federation
IEC	International Electrotechnical Commission
IM	International Mounting Code
IP	International Protection Code
NEMA	National Electrical Manufacturers Association
UkrSEPRO	Certificate for Ukraine
UL	Underwriters Laboratory Listed Product
UR	Underwriters Laboratory Recognized Product
VDE	Verband deutscher Elektrotechniker (Association of German Electrical Engineers)

MCS synchronous servo motors

General information



Product key

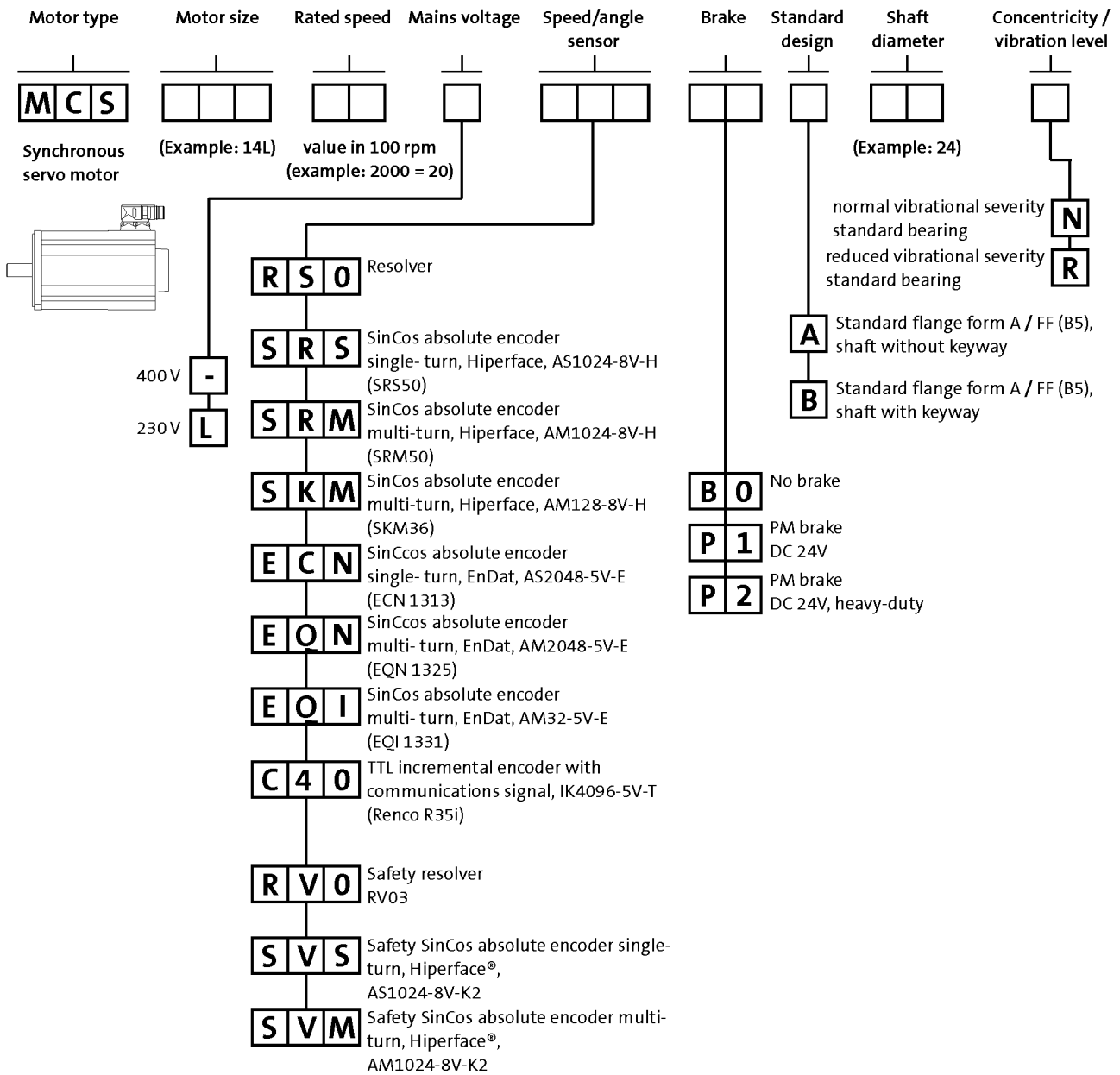

MCS synchronous servo motors

General information



Product key

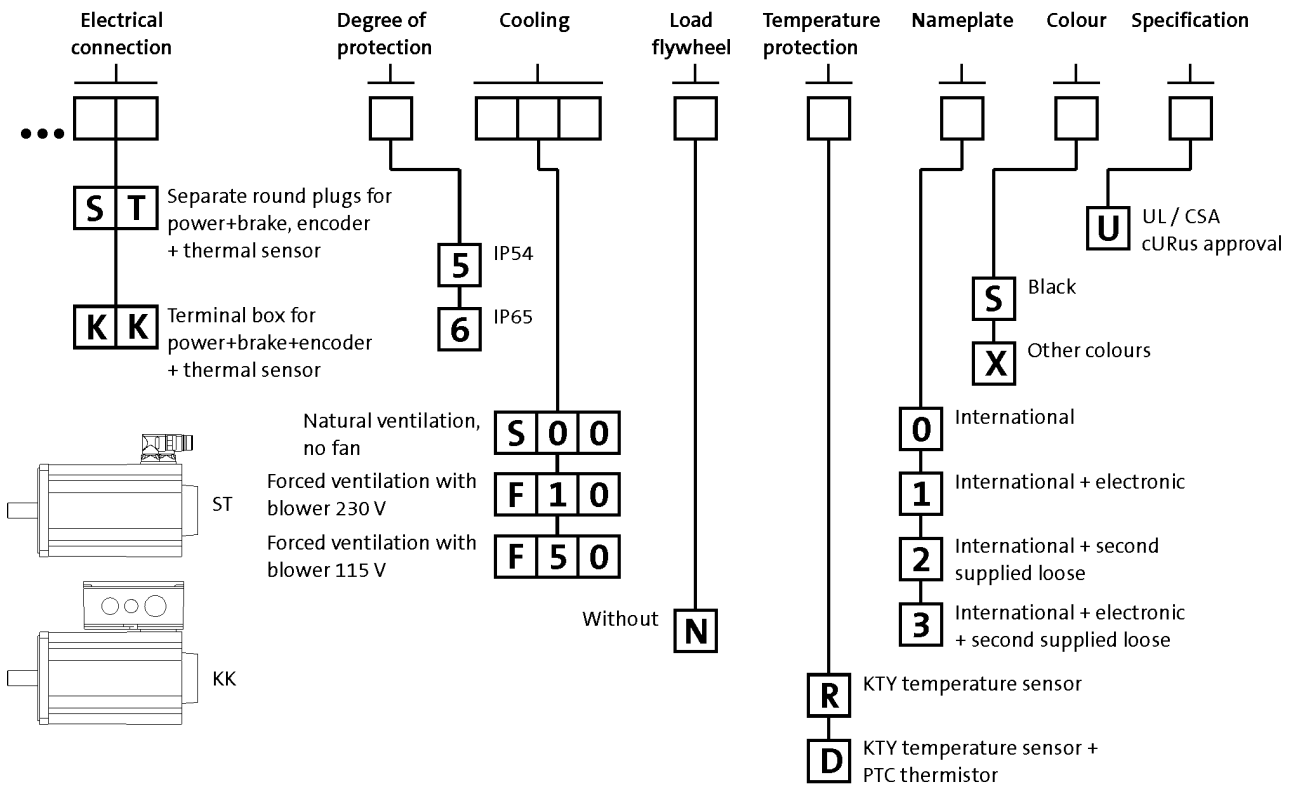

MCS synchronous servo motors

General information



Product information

When space is limited, but strict requirements in terms of dynamics and precision still have to be met, the MCS synchronous servo motors are the right choice.

With a power range from 0.25 kW to 15.8 kW and a rated torque range from 0.5 Nm to 72 Nm and peak torques of up to 190 Nm, these motors leave nothing to be desired in installations requiring compact and dynamic drive technology.

The stator winding of the MCS motors employs innovative Single Element Pole Technology – SEPT – and is made up of individual coils. High-quality magnetic materials and specially developed pole shapes set the conditions for their excellent drive characteristics. This results in a significant increase in power density, while at the same time reducing moments of inertia. The minimum detent torques offer exceptional smooth running characteristics and thereby secure excellent control behaviour.

The robust mechanical structure with reinforced bearings, the high degree of protection and the full stator encapsulation increase operational reliability, even in harsh ambient conditions.

Advantages

- High dynamic performance thanks to low moments of inertia
- Compact size with high power density
- Cooling with or without axial external fan
- Robust regenerative resolver system as standard
- Alternatively sin/cos encoder for the highest precision
- Easy to install and service friendly thanks to use of SpeedTec connectors
- Optional terminal box
- Protection: IP54, IP65 optional
- cURus-approved, GOST-certified, CE, RoHS compliant
- Smooth surface
- Single Element Pole Technology
- Optimum rotation characteristics
- Virtually free of detent torque
- Electronic nameplate



MCS09 synchronous servo motor

MCS synchronous servo motors

General information



Functions and features

	MCS06	MCS09	MCS12	MCS14	MCS19
Design					
	B5-FF75	B5-FF100	B5-FF130	B5-FF165	B5-FF215
Shaft end (with and without keyway)					
	11 x 23	14 x 30	19 x 40	24 x 50	28 x 60
A end shield	Not oil-tight				
Brake					
Permanent magnetic brake	DC 24 V	DC 24 V 24 V DC, reinforced			
Speed and angle encoder	Resolver SinCos single-turn/multi-turn				
Cooling					
Without blower	Naturally ventilated				
Axial blower, 1 phase					230 V; 50 Hz 115 V; 60 Hz
Thermal sensor					
Thermal detector	KTY				
PTC thermistor	2x PTC additional (3-phase monitoring)				
Motor connection: plug connector					
	Power + brake Encoder + thermal sensor		Power + brake Encoder + thermal sensor Blower		
Motor connection: terminal box	Power + brake + encoder + thermal sensor				
Shaft bearings					
Bearing type	Deep-groove ball bearing with high-temperature resistant grease, sealing disc or cover plate				
Position of the locating bearing	Non-drive end				
Colour	RAL9005M				

- Terminal boxes not possible if blower is fitted.

MCS synchronous servo motors



General information

Dimensioning

Speed-dependent safety functions

Single encoder concepts with resolvers

Servo motors can perform speed-dependent safety functions for safe speed and / or safe relative position monitoring in a drive system with the Servo Drives 9400. The SM301 safety module, which can be integrated in the Servo Drives 9400, is used to implement these functions. When planning systems/installations of this kind, the following must always be observed:

When using just one single feedback system in the environment of these safety applications, the applicable safety engineering standard IEC 61800-5-2 [Adjustable speed electrical power drive systems - Part: 5-2: Safety requirements - Functional] stipulates special requirements for the connection between feedback system and motor shaft. This is due to the fact that two-channel safety systems at this point in the mechanical system are actually designed as single-channel systems. If this mechanical connection is designed with considerable overdimensioning, the standard permits exclusion of the fault "encoder-shaft breakage" or "encoder-shaft slip". As such, acceleration limit values must not be exceeded for the individual drive solutions. You can find the limit values in the corresponding feedback data of the individual motor ranges.

Speed-dependent safety functions in connection with the SM301 safety module

For the following speed-dependent safety functions, the motor-feedback system combinations listed in the following table are available:

- Safe stop 1 (SS1)
- Safe operational stop (SOS)
- Safely Limited Speed (SLS)
- Safe Maximum Speed (SMS)

- Safe direction (SDI)
- Operation mode selector (OMS) with confirmation (ES)
- Safe speed monitor (SSM)
- Safely limited increment (SLI).

Encoder type	Encoder type	Product key	Feedback Design	Safe speed monitoring
SinCos absolute value	Single-turn	AS1024-8V-K2	2-encoder concept	PL d/SIL 2
	Multi-turn	AM1024-8V-K2		PL e/SIL 3
Resolver		RV03		up to PL e / SIL 3

MCS synchronous servo motors



General information

Dimensioning

Cooling effect of mounting flange

Mounting on a thermally conducting / insulating plate or machine chassis has an influence on heating up the motor, particularly when using naturally ventilated motors.

The motor rating data specified in the catalogue applies when mounting on a steel plate with free convection with the following dimensions:

- MCS06: 270 x 270 mm
- MCS09: 330 x 330 mm
- MCS12 / 14 / 19: 450 x 450 mm

Vibrational severity

		MCS06	MCS09	MCS12	MCS14	MCS19
Vibrational severity						
IEC/EN 60034-14				A		
Maximum r.m.s. value of the vibration velocity ¹⁾	[mm/s]			1.60		

¹⁾ Free suspension

- ▶ at n = 600 to 3,600 rpm



Dimensioning

Concentricity and axial run-out of the mounting flanges and smooth running of the shaft ends

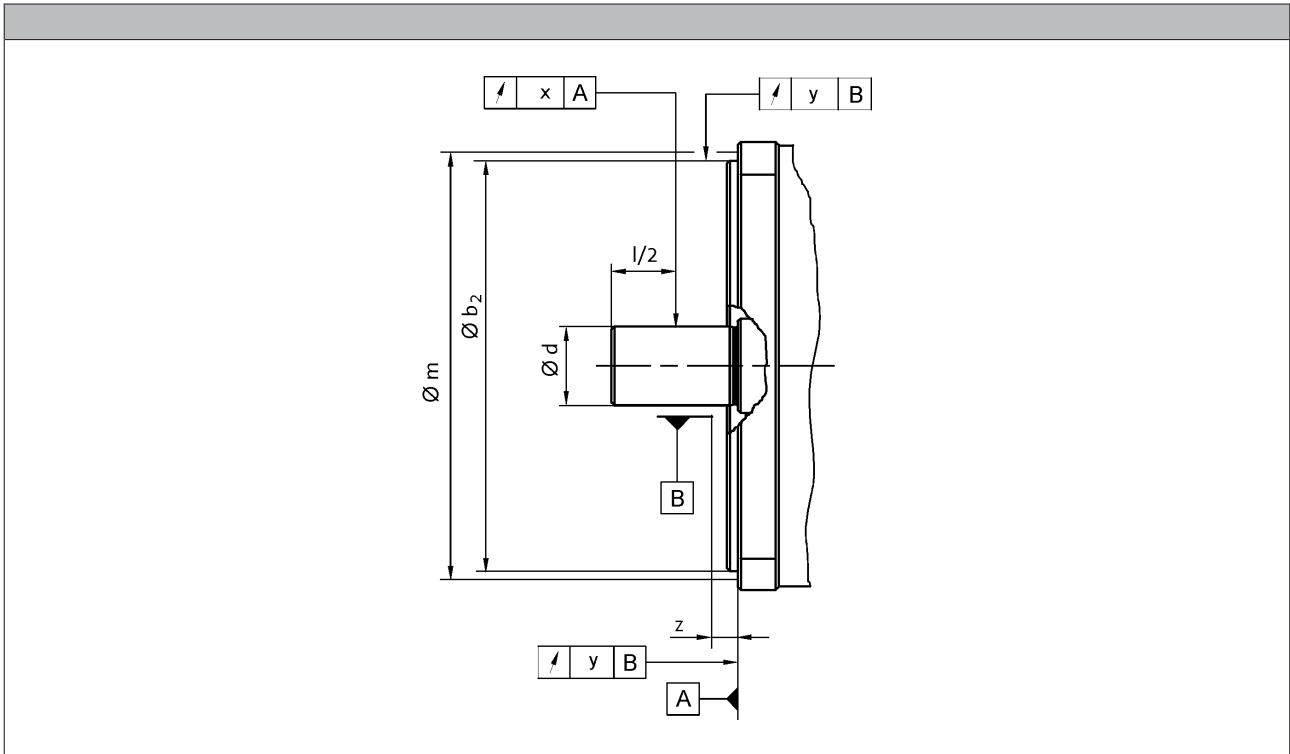

				MCS06	MCS09	MCS12	MCS14	MCS19
Flange size				FF75	FF100	FF130	FF165	FF215
Dimensions								
	b_2	j_6	[mm]	60	80	110	130	180
	d	k_6	[mm]	11	14	19	24	28
Distance								
Measuring diameter	m		[mm]	65.0	85.0	115	135	185
Dial gauge holder for flange check	z	± 1	[mm]	10.0				
Concentricity				Normal class				
IEC 60072				0.080		0.10		
Value	y		[mm]	0.080		0.10		
Linear movement				Normal class				
IEC 60072				0.080		0.10		
Value	y		[mm]	0.080		0.10		
Smooth running				Normal class				
IEC 60072				0.035		0.040		
Value	x		[mm]	0.035		0.040		

- Limit values for checking the smooth running of the shaft ends as well as the concentricity and axial run-out of the mounting flange to IEC 60072

MCS synchronous servo motors

General information



Dimensioning

Notes on the selection tables

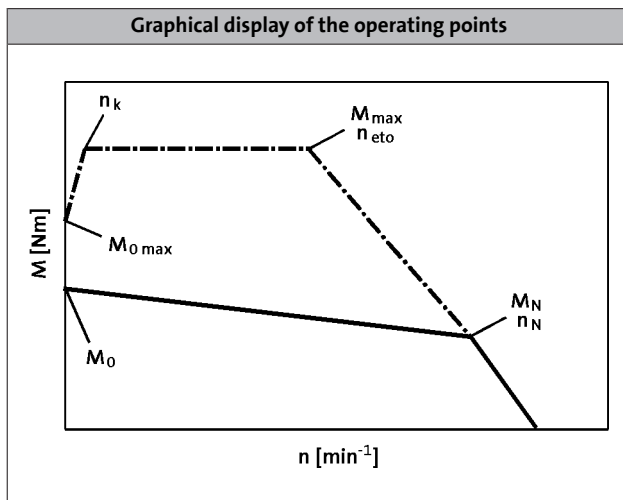

Please note:

- In case of an active load (e.g. vertical drive axes, hoists, test benches, unwinders), $M_{0\max}$ has to be considered
- In case of a passive load (e.g. horizontal drive axes), M_{\max} can be usually used
- In case of a speed $< n_k$ and inverter-specifically, the achievable torque $M_{0\max}$ is smaller than M_{\max}
- In case of a speed $n = 0$, the standstill torque M_0 and the standstill current I_0 have to be reduced by 30% after 2 seconds. In case of applications which require a longer holding of M_0 , we recommend the drive to be held via the holding brake and reduce the current, e.g. by controller inhibit.
- In case of servo inverters, the switching frequency dependent overload capacity is considered in the default setting. For more information, see the servo inverter catalogue.

	n_k [r/min]
MCS	75.0
MDSKS	100
MDFKS	

Further selection tables with different switching frequencies are available with the following codes:

- DS_ZT_MCS_0001
- DS_ZT_MCA_0001
- DS_ZT_MDSKS_0001
- DS_ZT_MDFKS_0001

Simply enter this code (e.g. DS_ZT_MCS_0001) as a search string at www.lenze.de/dsc and you will be given the information immediately in the form of a PDF format.

MCS synchronous servo motors

General information



Dimensioning

Notes on the torque characteristics

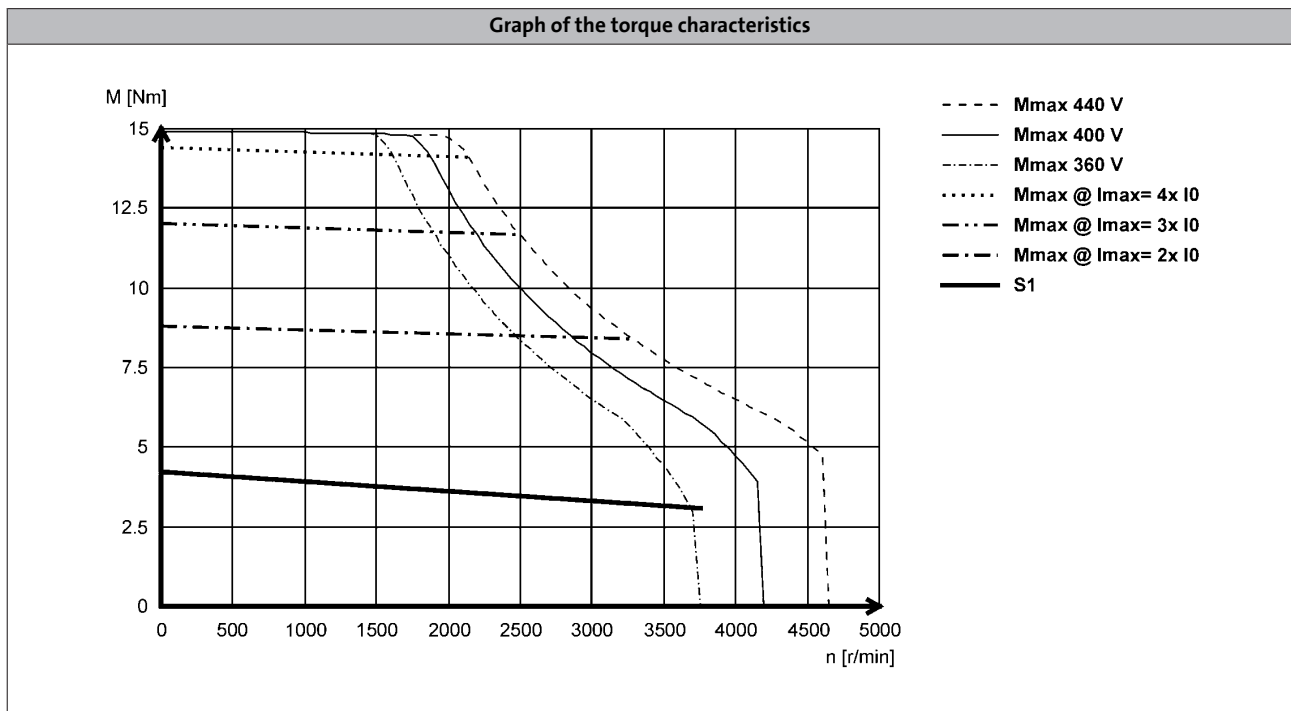

With synchronous servo motors, the limit torque characteristics that result from the selection of servo inverters with maximum currents are also shown alongside the characteristics for continuous operation (S1). These correspond to a multiple of the motor standstill current ($2 \times I_0$ to $4 \times I_0$).

Characteristics in the Internet

You can find the torque characteristic for inverter-motor combinations on the Internet at www.lenze.de/dsc. This lists all useful combinations with the servo inverters 9400, 9300, ECS and Inverter Drives 8400 TopLine. These characteristics are each determined using the factory default settings of the inverters:

- 9400 with variable switching frequency.
This means that up to 6-fold overcurrent can be applied in borderline cases.
- 9300 and ECS with fixed switching frequency.
- 8400 TopLine with variable switching frequency.

The continuous operation characteristics (S1) show the inverter-independent motor rating values

Further information on the terms switching frequency and factory default settings can be found in the operating manual of the respective servo inverter.

MCS synchronous servo motors

General information



Dimensioning

Influence of ambient temperature and site altitude

The information relating to the servo motors in the tables and graphs is valid for a maximum ambient temperature (T_{opr}) of 40 °C and a site altitude (H) up to 1000 m above sea level. The torque correction factor (k_{M1}) shall be applied to the S1 torque characteristic ($M_0...M_N$) in the event of differing installation conditions.

- The maximum permissible ambient temperature (T_{opr}) for servo motors with blowers is 40 °C

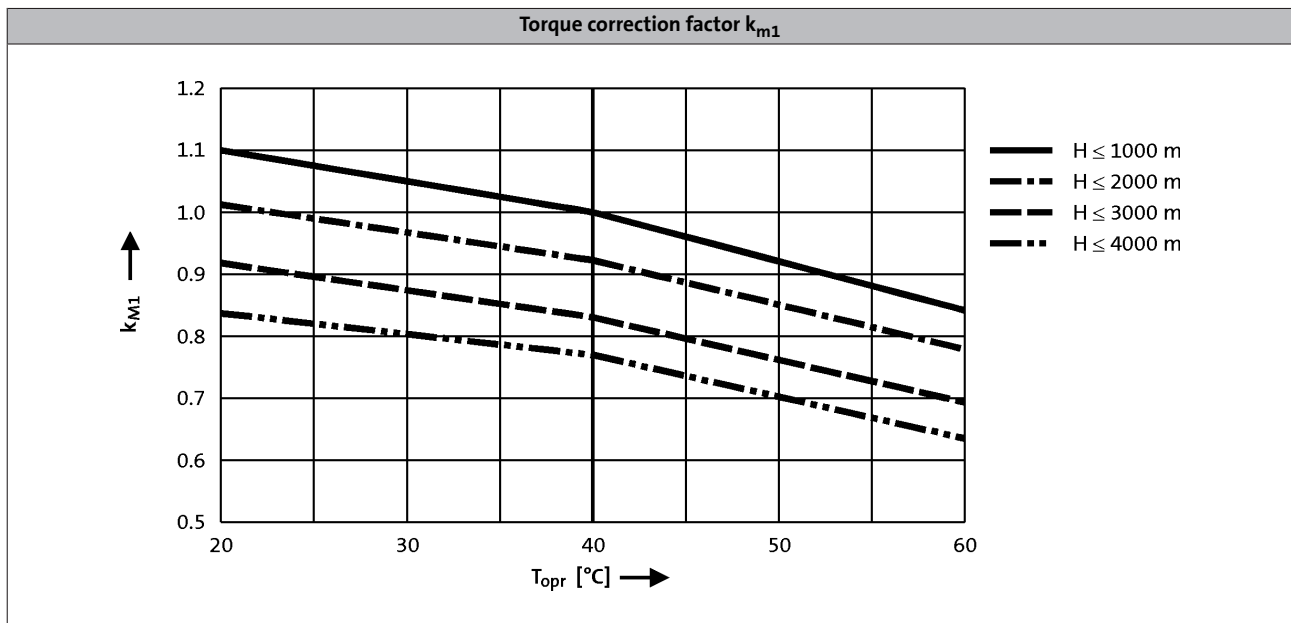

MCS synchronous servo motors

General information



MCS synchronous servo motors

Technical data



Standards and operating conditions

			MCS	
Cooling type			Naturally ventilated	Blower
Enclosure				
EN 60529			IP54 IP65	IP54
Temperature class				
IEC/EN 60034-1; utilisation			F	
IEC/EN 60034-1; insulation system (enamel-insulated wire)			H	
Conformity				
CE			Low-Voltage Directive 2006/95/EC	
EAC			TP TC 004/2011 (TR C	
Approval				
			UkrSEPRO	
CSA			CSA 22.2 No. 100	
cURus			UL 1004-1 UL 1004-6 Power Conversion Equipment (File-No. E210321)	
Max. voltage load				
IEC/TS 60034-25			Pulse voltage limiting curve A	
Smooth running				
IEC 60072			Normal class	
Linear movement				
IEC 60072			Normal class	
Concentricity				
IEC 60072			Normal class	
Mechanical ambient conditions (vibration)				
IEC/EN 60721-3-3			3M6	
Min. ambient operating temperature				
Without brake	$T_{opr,min}$	[°C]	-20	-15
With brake	$T_{opr,min}$	[°C]	-10	
Max. ambient temperature for operation				
	$T_{opr,max}$	[°C]	40	
Max. surface temperature				
	T	[°C]	140	110
Mechanical tolerance				
Flange centring diameter			$b_2 \leq 230 \text{ mm} = j6$ $b_2 > 230 \text{ mm} = h6$	
Shaft diameter			$d \leq 50 \text{ mm} = k6$ $d > 50 \text{ mm} = m6$	
Site altitude				
Amsl	H_{max}	[m]	4000	

MCS synchronous servo motors

Technical data



Permissible radial and axial forces

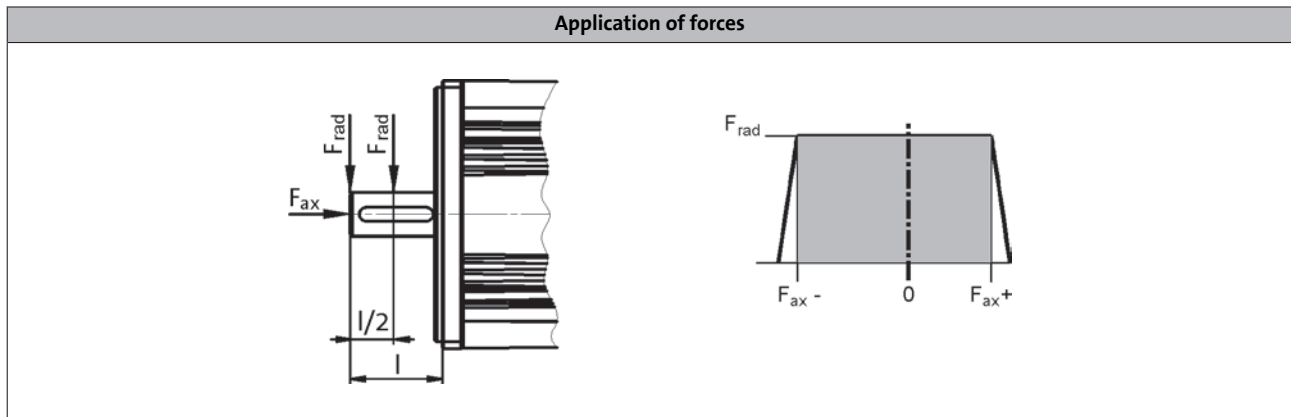

Application of force at $l/2$

	Bearing service life L_{10}														
	5000 h			10000 h			20000 h			30000 h			50000 h		
	F_{rad}	$F_{ax,-}$	$F_{ax,+}$	F_{rad}	$F_{ax,-}$	$F_{ax,+}$	F_{rad}	$F_{ax,-}$	$F_{ax,+}$	F_{rad}	$F_{ax,-}$	$F_{ax,+}$	F_{rad}	$F_{ax,-}$	$F_{ax,+}$
	[N]	[N]	[N]	[N]	[N]	[N]	[N]	[N]	[N]	[N]	[N]	[N]	[N]	[N]	[N]
MCS06	740	-260	140	590	-210	80	470	-170	40	410	-150	30	340	-140	10
MCS09	1040	-700	470	830	-550	310	660	-440	200	580	-380	150	490	-330	90
MCS12	1030	-880	560	820	-690	370	650	-550	230	570	-490	160	480	-420	100
MCS14	1830	-1150	720	1450	-900	470	1150	-720	290	1010	-640	200	850	-550	120
MCS19	3840	-1550	950	3050	-1210	620	2430	-960	360	2120	-840	250	1790	-730	130

Application of force at l

	Bearing service life L_{10}														
	5000 h			10000 h			20000 h			30000 h			50000 h		
	F_{rad}	$F_{ax,-}$	$F_{ax,+}$	F_{rad}	$F_{ax,-}$	$F_{ax,+}$	F_{rad}	$F_{ax,-}$	$F_{ax,+}$	F_{rad}	$F_{ax,-}$	$F_{ax,+}$	F_{rad}	$F_{ax,-}$	$F_{ax,+}$
	[N]	[N]	[N]	[N]	[N]	[N]	[N]	[N]	[N]	[N]	[N]	[N]	[N]	[N]	[N]
MCS06	630	-210	90	500	-170	50	400	-140	20	350	-130	0	290	-120	-10
MCS09	900	-630	400	710	-500	260	570	-400	160	500	-350	120	420	-300	70
MCS12	890	-820	490		-640	320	560	-520	190	490	-460	130		-400	
MCS14	1590	-1040	610	1260	-820	390	1000	-660	230	880	-580	150	740	-510	
MCS19	3330	-1320	730	2650	-1040	450	2100	-830	240	1840	-740	140	1550	-640	40

- The values for the bearing service life L_{10} refer to an average speed of 4000 r/min. Depending on the ambient temperatures, the service life of the bearings is also reduced by the grease life-time.

MCS synchronous servo motors

Technical data



Rated data, non-ventilated

► The data applies to a mains connection voltage of 3 x 400 V.

	n_N [r/min]	M_0 [Nm]	M_N [Nm]	M_{max} [Nm]	P_N [kW]	I_0 [A]	I_N [A]	I_{max} [A]	$U_{N, AC}$ [V]	f_N [Hz]
MCS06C41-	4050	0.80	0.60	2.40	0.25	1.30	1.30	5.40	225	270
MCS06C60-	6000	0.80	0.50	2.40	0.31	2.50	2.40	10.8	135	400
MCS06F41-	4050	1.50	1.20	4.40	0.51	1.50	1.50	5.30	320	270
MCS06F60-	6000	1.50	0.90	4.40	0.57	2.90	2.50	10.5	180	400
MCS06I41-	4050	2.00	1.50	6.20	0.64	1.70	1.60	5.90	325	270
MCS06I60-	6000	2.00	1.20	6.20	0.75	3.40	2.90	11.8	190	400
MCS09D41-	4050	3.30	2.30	9.50	1.00	2.60	2.30	10.0	320	270
MCS09D60-	6000	3.30	1.80	9.50	1.10	5.30	3.80	20.0	210	400
MCS09F38-	3750	4.20	3.10	15.0	1.20	3.00	2.50	15.0	330	250
MCS09F60-	6000	4.20	2.40	15.0	1.50	6.00	4.50	30.0	230	400
MCS09H41-	4050	5.50	3.80	20.0	1.60	4.30	3.40	20.0	300	270
MCS09H60-	6000	5.50	3.00	20.0	1.90	8.50	6.00	40.0	190	400
MCS09L41-	4050	7.50	4.50	32.0	1.90	6.20	4.20	32.0	295	270
MCS09L51-	5100	7.50	3.60	32.0	1.90	12.4	6.90	64.0	180	340

	$\eta_{100\%}$ [%]	$J^{1)}$ [kgcm ²]	$KE_{LL 150\text{ }^\circ\text{C}}$ [V / 1000 rp]	$R_{UV 20\text{ }^\circ\text{C}}$ [Ω]	$R_{UV 150\text{ }^\circ\text{C}}$ [Ω]	L_N [mH]	$Kt_{0 150\text{ }^\circ\text{C}}$ [Nm/A]	$n_{max}^{2)}$ [r/min]	$m^{1)}$ [kg]
MCS06C41-	65.0	0.14	36.6	27.1	36.5	51.0	0.66	8000	1.80
MCS06C60-	70.0	0.14	18.3	6.80	9.10	12.8	0.33	8000	1.80
MCS06F41-	77.0	0.22	60.1	21.9	29.5	63.5	1.05	8000	2.20
MCS06F60-	81.0	0.22	30.0	5.50	7.40	15.9	0.53	8000	2.20
MCS06I41-	81.0	0.30	73.4	18.8	25.4	60.2	1.21	8000	2.90
MCS06I60-	84.0	0.30	36.7	4.70	6.30	15.1	0.60	8000	2.90
MCS09D41-	87.0	1.10	71.2	7.00	9.40	25.1	1.25	7000	4.30
MCS09D60-	87.0	1.10	35.6	1.80	2.40	6.30	0.62	7000	4.30
MCS09F38-	91.0	1.50	79.8	5.20	7.00	24.6	1.40	7000	5.20
MCS09F60-	91.0	1.50	39.9	1.30	1.80	6.20	0.70	7000	5.20
MCS09H41-	91.0	1.90	75.7	3.20	4.30	16.1	1.29	7000	6.10
MCS09H60-	91.0	1.90	37.8	0.80	1.10	4.00	0.65	7000	6.10
MCS09L41-	91.0	2.80	71.7	1.80	2.40	9.90	1.21	7000	7.90
MCS09L51-	91.0	2.80	35.9	0.44	0.59	2.50	0.60	7000	7.90

¹⁾ Without brake.

²⁾ Mechanically permissible maximum speed.

MCS synchronous servo motors

Technical data



Rated data, non-ventilated

► The data applies to a mains connection voltage of 3 x 400 V.

	n_N [r/min]	M_0 [Nm]	M_N [Nm]	M_{max} [Nm]	P_N [kW]	I_0 [A]	I_N [A]	I_{max} [A]	$U_{N, AC}$ [V]	f_N [Hz]
MCS12D20-	1950	6.40	5.50	18.0	1.10	2.70	2.60	10.0	345	130
MCS12D41-	4050	6.40	4.30	18.0	1.80	5.50	4.50	20.0	310	270
MCS12H15-	1500	11.4	10.0	29.0	1.60	4.10	3.80	12.0	300	100
MCS12H35-	3525	11.4	7.50	29.0	2.80	8.20	5.70	24.0	325	235
MCS12L20-	1950	15.0	13.5	56.0	2.80	6.20	5.90	28.0	330	130
MCS12L41-	4050	15.0	11.0	56.0	4.70	12.4	10.2	57.0	300	270
MCS14D15-	1500	11.0	9.20	29.0	1.45	5.00	4.50	17.0	305	100
MCS14D36-	3600	11.0	7.50	29.0	2.80	10.0	7.50	33.0	295	240
MCS14H15-	1500	21.0	16.0	55.0	2.50	8.50	6.60	26.0	325	100
MCS14H32-	3225	21.0	14.0	55.0	4.70	16.9	11.9	52.0	295	215
MCS14L15-	1500	28.0	23.0	77.0	3.60	12.0	9.70	37.0	315	100
MCS14L32-	3225	28.0	17.2	77.0	5.80	24.0	15.0	75.0	275	215
MCS14P14-	1350	37.0	30.0	105	4.20	12.2	10.8	46.0	340	90
MCS14P32-	3225	37.0	21.0	105	7.10	24.3	15.6	92.0	315	215

	$\eta_{100\%}$ [%]	$J^{1)}$ [kgcm ²]	$KE_{LL, 150\text{ }^\circ\text{C}}$ [V / 1000 rp]	$R_{UV, 20\text{ }^\circ\text{C}}$ [Ω]	$R_{UV, 150\text{ }^\circ\text{C}}$ [Ω]	L_N [mH]	$Kt_{0, 150\text{ }^\circ\text{C}}$ [Nm/A]	$n_{max}^{2)}$ [r/min]	$m^{1)}$ [kg]
MCS12D20-	79.0	4.00	137	8.70	11.8	52.2	2.34	6000	6.40
MCS12D41-	84.0	4.00	68.6	2.20	2.90	13.0	1.17	6000	6.40
MCS12H15-	88.0	7.30	173	5.70	7.70	42.1	2.79	6000	9.50
MCS12H35-	91.0	7.30	86.5	1.40	1.90	10.5	1.40	6000	9.50
MCS12L20-	90.0	10.6	149	2.20	3.00	21.8	2.42	6000	12.6
MCS12L41-	91.0	10.6	74.6	0.55	0.75	5.50	1.21	6000	12.6
MCS14D15-	88.0	8.10	129	4.00	5.40	49.8	2.19	6000	10.7
MCS14D36-	92.0	8.10	64.2	1.00	1.35	12.5	1.09	6000	10.7
MCS14H15-	92.0	14.2	153	2.08	2.81	34.1	2.48	6000	15.5
MCS14H32-	93.0	14.2	76.3	0.52	0.70	8.50	1.24	6000	15.5
MCS14L15-	90.0	23.4	152	1.21	1.64	22.0	2.33	6000	20.1
MCS14L32-	93.0	23.4	76.2	0.30	0.41	5.50	1.16	6000	20.1
MCS14P14-	90.0	34.7	179	1.10	1.49	23.9	3.04	6000	24.9
MCS14P32-	93.0	34.7	89.4	0.28	0.37	6.00	1.52	6000	24.9

¹⁾ Without brake.

²⁾ Mechanically permissible maximum speed.

MCS synchronous servo motors

Technical data



Rated data, non-ventilated

► The data applies to a mains connection voltage of 3 x 400 V.

	n_N [r/min]	M_0 [Nm]	M_N [Nm]	M_{max} [Nm]	P_N [kW]	I_0 [A]	I_N [A]	I_{max} [A]	$U_{N, AC}$ [V]	f_N [Hz]
MCS19F14-	1425	32.0	27.0	86.0	4.00	9.90	8.60	31.0	335	95
MCS19F30-	3000	32.0	21.0	86.0	6.60	19.8	14.0	63.0	300	200
MCS19J14-	1425	51.0	40.0	129	6.00	15.2	12.3	45.0	330	95
MCS19J30-	3000	51.0	29.0	129	9.10	30.5	18.5	90.0	300	200
MCS19P14-	1350	64.0	51.0	190	7.20	17.5	14.3	60.0	330	90
MCS19P30-	3000	64.0	32.0	190	10.0	34.9	19.0	120	320	200

	$\eta_{100\%}$ [%]	$J^1)$ [kgcm ²]	$KE_{LL 150\text{ °C}}$ [V / 1000 rp]	$R_{UV 20\text{ °C}}$ [Ω]	$R_{UV 150\text{ °C}}$ [Ω]	L_N [mH]	$Kt_{0 150\text{ °C}}$ [Nm/A]	$n_{max}^2)$ [r/min]	$m^1)$ [kg]
MCS19F14-	92.0	65.0	195	1.30	1.75	20.8	3.23	4000	23.0
MCS19F30-	93.0	65.0	97.2	0.32	0.44	5.20	1.62	4000	23.0
MCS19J14-	92.0	105	199	0.65	0.88	12.8	3.31	4000	30.0
MCS19J30-	93.0	105	99.5	0.16	0.22	3.20	1.65	4000	30.0
MCS19P14-	92.0	160	216	0.54	0.73	9.60	3.66	4000	40.0
MCS19P30-	93.0	160	108	0.14	0.18	2.40	1.83	4000	40.0

¹⁾ Without brake.

²⁾ Mechanically permissible maximum speed.

MCS synchronous servo motors

Technical data



Rated data, non-ventilated

► The data applies to a mains connection voltage of 3 x 230 V.

	n_N [r/min]	M_0 [Nm]	M_N [Nm]	M_{max} [Nm]	P_N [kW]	I_0 [A]	I_N [A]	I_{max} [A]	$U_{N, AC}$ [V]	f_N [Hz]
MCS06C41L	4050	0.80	0.60	2.40	0.25	2.50	2.50	10.8	125	270
MCS06C60L	6000	0.80	0.50	2.40	0.31	4.30	4.00	18.5	85	400
MCS06F41L	4050	1.50	1.20	4.40	0.51	2.90	2.90	10.5	165	270
MCS06F60L	6000	1.50	0.90	4.40	0.57	3.80	3.40	16.5	125	400
MCS06I41L	4050	2.00	1.50	6.20	0.64	3.10	2.90	11.8	175	270
MCS06I60L	6000	2.00	1.20	6.20	0.75	4.20	3.60	16.0	150	400
MCS09D41L	4050	3.30	2.30	9.50	1.00	5.30	4.60	20.0	165	270
MCS09D60L	6000	3.30	1.80	9.50	1.10	10.3	7.00	39.0	110	400
MCS09F38L	3750	4.20	3.10	15.0	1.20	6.00	5.00	30.0	160	250
MCS09F60L	6000	4.20	2.40	15.0	1.50	10.5	7.90	53.0	125	400
MCS09H41L	4050	5.50	3.80	20.0	1.60	8.50	6.80	40.0	160	270
MCS09H60L	6000	5.50	3.00	20.0	1.90	12.0	8.00	57.0	145	400
MCS09L41L	4050	7.50	4.50	32.0	1.90	12.4	8.40	64.0	145	270

	$\eta_{100\%}$ [%]	$J^{1)}$ [kgcm ²]	$KE_{LL 150\text{ °C}}$ [V / 1000 rp]	$R_{UV 20\text{ °C}}$ [Ω]	$R_{UV 150\text{ °C}}$ [Ω]	L_N [mH]	$Kt_{0 150\text{ °C}}$ [Nm/A]	$n_{max}^{2)}$ [r/min]	$m^{1)}$ [kg]
MCS06C41L	65.0	0.14	21.5	6.00	8.00	12.8	0.33	8000	1.80
MCS06C60L	70.0	0.14	12.5	2.20	2.90	4.30	0.19	8000	1.80
MCS06F41L	81.0	0.22	34.5	5.50	7.40	15.9	0.62	8000	2.20
MCS06F60L	82.0	0.22	22.2	2.30	3.00	6.90	0.40	8000	2.20
MCS06I41L	81.0	0.30	38.0	4.70	6.20	15.1	0.64	8000	2.90
MCS06I60L	84.0	0.30	28.5	2.50	3.40	9.30	0.48	8000	2.90
MCS09D41L	87.0	1.10	35.6	1.80	2.40	6.30	0.62	7000	4.30
MCS09D60L	87.0	1.10	18.3	0.45	0.61	1.70	0.32	7000	4.30
MCS09F38L	90.0	1.50	39.9	1.30	1.80	6.20	0.70	7000	5.20
MCS09F60L	91.0	1.50	22.8	0.42	0.56	2.00	0.40	7000	5.20
MCS09H41L	91.0	1.90	37.8	0.80	1.10	4.00	0.65	7000	6.10
MCS09H60L	91.0	1.90	26.6	0.36	0.48	2.00	0.46	7000	6.10
MCS09L41L	91.0	2.80	35.9	0.44	0.59	2.50	0.60	7000	7.90

¹⁾ Without brake.

²⁾ Mechanically permissible maximum speed.

MCS synchronous servo motors

Technical data



Rated data, non-ventilated

► The data applies to a mains connection voltage of 3 x 230 V.

	n_N [r/min]	M_0 [Nm]	M_N [Nm]	M_{max} [Nm]	P_N [kW]	I_0 [A]	I_N [A]	I_{max} [A]	$U_{N, AC}$ [V]	f_N [Hz]
MCS12D20L	1950	6.40	5.50	18.0	1.10	5.50	5.20	20.0	175	130
MCS12D41L	4050	6.40	4.30	18.0	1.80	10.7	8.80	40.0	155	270
MCS12H15L	1500	11.4	10.0	29.0	1.60	8.20	7.80	24.0	158	100
MCS12H30L	3000	11.4	8.00	29.0	2.50	13.5	10.5	39.0	165	200
MCS12L20L	1950	15.0	13.5	56.0	2.80	12.4	11.8	57.0	165	130

	$\eta_{100\%}$ [%]	$J^{1)}$ [kgcm ²]	$KE_{LL, 150\text{ °C}}$ [V / 1000 rp]	$R_{UV, 20\text{ °C}}$ [Ω]	$R_{UV, 150\text{ °C}}$ [Ω]	L_N [mH]	$Kt_{0, 150\text{ °C}}$ [Nm/A]	$n_{max}^{2)}$ [r/min]	$m^{1)}$ [kg]
MCS12D20L	79.0	4.00	68.6	2.20	2.90	13.0	1.17	6000	6.40
MCS12D41L	84.0	4.00	35.0	0.55	0.75	3.40	0.60	6000	6.40
MCS12H15L	82.0	7.30	86.5	1.41	1.90	10.5	1.40	6000	9.50
MCS12H30L	87.0	7.30	53.0	0.50	0.67	4.00	0.86	6000	9.50
MCS12L20L	90.0	10.6	76.9	0.55	0.75	5.50	1.21	6000	12.6

¹⁾ Without brake.

²⁾ Mechanically permissible maximum speed.

MCS synchronous servo motors

Technical data



Rated data, forced ventilated

► The data applies to a mains connection voltage of 3 x 400 V.

	n_N [r/min]	M_0 [Nm]	M_N [Nm]	M_{max} [Nm]	P_N [kW]	I_0 [A]	I_N [A]	I_{max} [A]	$U_{N, AC}$ [V]	f_N [Hz]
MCS12D17-	1650	7.50	7.00	17.7	1.20	3.20	3.00	10.0	330	110
MCS12D35-	3525	7.50	6.00	17.7	2.20	6.40	5.60	20.0	300	235
MCS12H14-	1350	12.8	12.0	29.0	1.70	4.30	4.10	12.0	310	90
MCS12H34-	3375	12.8	10.5	29.0	3.70	8.50	7.50	24.0	320	225
MCS12L17-	1650	19.0	17.0	56.4	2.90	7.20	6.70	28.0	300	110
MCS12L39-	3900	19.0	14.0	56.4	5.70	14.4	11.7	57.0	295	260
MCS14D14-	1350	12.5	12.0	29.0	1.70	5.70	5.40	17.0	345	90
MCS14D30-	3000	12.5	10.5	29.0	3.30	11.4	9.70	33.0	325	200
MCS14H12-	1200	25.5	23.5	54.8	3.00	9.30	8.30	26.0	335	80
MCS14H28-	2775	25.5	20.5	54.8	6.00	18.4	15.0	52.0	325	185
MCS14L14-	1350	34.5	30.5	77.1	4.30	13.4	11.8	37.0	335	90
MCS14L30-	3000	34.5	25.5	77.1	8.00	26.7	20.8	75.0	310	200
MCS14P11-	1050	43.5	42.0	105	4.60	14.1	13.4	46.0	330	70
MCS14P26-	2625	43.5	33.0	105	9.10	28.3	21.9	92.0	325	175

	$\eta_{100\%}$ [%]	$J^{1)}$ [kgcm ²]	$KE_{LL, 150\text{ }^\circ\text{C}}$ [V / 1000 rp]	$R_{UV, 20\text{ }^\circ\text{C}}$ [Ω]	$R_{UV, 150\text{ }^\circ\text{C}}$ [Ω]	L_N [mH]	$Kt_{0, 150\text{ }^\circ\text{C}}$ [Nm/A]	$n_{max}^{2)}$ [r/min]	$m^{1)}$ [kg]
MCS12D17-	75.0	4.00	137	8.72	11.8	52.2	2.34	6000	8.50
MCS12D35-	82.0	4.00	68.6	2.18	2.94	13.0	1.17	6000	8.50
MCS12H14-	80.0	7.30	173	5.72	7.72	42.1	2.98	6000	11.6
MCS12H34-	86.0	7.30	86.5	1.39	1.88	10.5	1.51	6000	11.6
MCS12L17-	90.0	10.6	149	2.22	2.99	21.8	2.64	6000	14.7
MCS12L39-	94.0	10.6	74.6	0.55	0.75	5.50	1.32	6000	14.7
MCS14D14-	84.0	8.10	129	4.00	5.40	49.8	2.19	6000	14.5
MCS14D30-	92.0	8.10	64.2	1.00	1.35	12.5	1.09	6000	14.5
MCS14H12-	87.0	14.2	153	2.08	2.81	34.1	2.75	6000	19.5
MCS14H28-	93.0	14.2	76.3	0.52	0.70	8.50	1.39	6000	19.5
MCS14L14-	88.0	23.4	152	1.21	1.64	22.0	2.57	6000	24.0
MCS14L30-	92.0	23.4	76.2	0.30	0.41	5.50	1.29	6000	24.0
MCS14P11-	86.0	34.7	179	1.10	1.49	23.9	3.08	6000	29.0
MCS14P26-	92.0	34.7	89.4	0.28	0.37	6.00	1.54	6000	29.0

¹⁾ Without brake.

²⁾ Mechanically permissible maximum speed.

MCS synchronous servo motors

Technical data



Rated data, forced ventilated

► The data applies to a mains connection voltage of 3 x 400 V.

	n_N [r/min]	M_0 [Nm]	M_N [Nm]	M_{max} [Nm]	P_N [kW]	I_0 [A]	I_N [A]	I_{max} [A]	$U_{N, AC}$ [V]	f_N [Hz]
MCS19F12-	1200	41.5	38.0	86.0	4.80	12.2	11.3	31.0	320	80
MCS19F29-	2850	41.5	32.5	86.0	9.70	24.5	20.1	63.0	320	190
MCS19J12-	1200	70.5	62.5	129	7.90	20.3	18.3	45.0	320	80
MCS19J29-	2850	70.5	50.5	129	15.1	40.6	31.0	90.0	315	190
MCS19P12-	1200	86.0	72.0	190	9.00	22.4	21.3	60.0	310	80
MCS19P29-	2850	86.0	53.0	190	15.8	44.7	29.5	120	315	190

	$\eta_{100\%}$ [%]	J^1 [kgcm ²]	$KE_{LL 150\text{ °C}}$ [V / 1000 rp]	$R_{UV 20\text{ °C}}$ [Ω]	$R_{UV 150\text{ °C}}$ [Ω]	L_N [mH]	$Kt_{0 150\text{ °C}}$ [Nm/A]	n_{max}^2 [r/min]	m^1 [kg]
MCS19F12-	90.4	65.0	195	1.30	1.75	20.8	3.40	4000	29.0
MCS19F29-	94.7	65.0	97.2	0.32	0.44	5.20	1.69	4000	29.0
MCS19J12-	89.3	105	199	0.65	0.88	12.8	3.47	4000	36.0
MCS19J29-	92.8	105	99.5	0.16	0.22	3.20	1.74	4000	36.0
MCS19P12-	90.3	160	216	0.54	0.73	9.60	3.84	4000	46.0
MCS19P29-	93.4	160	108	0.14	0.18	2.40	1.92	4000	46.0

¹⁾ Without brake.

²⁾ Mechanically permissible maximum speed.

MCS synchronous servo motors

Technical data



Selection tables, Servo Drives 9400 HighLine

Non-ventilated motors

- The data applies to a mains connection voltage of 3 x 400 V and an inverter switching frequency of 4 kHz.

					E94A□□	E0024	E0034	E0044	E0074	E0094	E0134	E0174	E0244	E0324	E0474	E0594
					I_N	1.9	3.1	5.0	8.8	11.7	16.3	20.6	29.4	38.4	47.0	59.0
					$I_{0,max}$	6.0	10.0	16.0	21.0	28.0	39.0	49.5	58.8	76.8	94.0	118.0
MCS	M_N	n_N	I_N	P_N	I_{max}	6.0	10.0	16.0	21.0	28.0	39.0	49.5	58.8	76.8	94.0	118.0
06C41-	0.6	4050	1.3	0.25	M_0	0.8										
					M_N	0.6										
					$M_{0,max}$	2.4										
					M_{max}	2.4										
					η_{eto}	-										
06C60-	0.5	6000	2.4	0.31	M_0	0.6	0.8									
					M_N	0.4	0.5									
					$M_{0,max}$	1.5	2.3									
					M_{max}	1.5	2.3									
					η_{eto}	-	-									
06F41-	1.2	4050	1.5	0.51	M_0	1.5										
					M_N	1.2										
					$M_{0,max}$	4.4										
					M_{max}	4.4										
					η_{eto}	-										
06F60-	0.9	6000	2.5	0.57	M_0	1.0	1.5									
					M_N	0.7	0.9									
					$M_{0,max}$	3.0	4.3									
					M_{max}	3.0	4.3									
					η_{eto}	-	-									
06I41-	1.5	4050	1.6	0.64	M_0	2.0										
					M_N	1.5										
					$M_{0,max}$	6.2										
					M_{max}	6.2										
					η_{eto}	-										
06I60-	1.2	6000	2.9	0.75	M_0	1.1	1.8	2.0								
					M_N	0.8	1.2	1.2								
					$M_{0,max}$	3.3	5.5	6.2								
					M_{max}	3.3	5.5	6.2								
					η_{eto}	-	-	-								
09D41-	2.3	4050	2.3	1.00	M_0	2.4	3.3									
					M_N	1.9	2.3									
					$M_{0,max}$	6.3	9.5									
					M_{max}	6.3	9.5									
					η_{eto}	-	-									
09D60-	1.8	6000	3.8	1.10	M_0			3.1	3.3							
					M_N			1.8	1.8							
					$M_{0,max}$			8.0	9.5							
					M_{max}			8.0	9.5							
					η_{eto}			-	-							
09F38-	3.1	3750	2.5	1.20	M_0		4.2	4.2								
					M_N		3.1	3.1								
					$M_{0,max}$		11.6	14.9								
					M_{max}		11.6	14.9								
					η_{eto}		-	-								

- $I...$ [A], $M...$ [Nm], $n...$ [r/min], $P...$ [kW]

6.11

MCS synchronous servo motors

Technical data



Selection tables, Servo Drives 9400 HighLine

Non-ventilated motors

- The data applies to a mains connection voltage of 3 x 400 V and an inverter switching frequency of 4 kHz.

					E94A□□	E0024	E0034	E0044	E0074	E0094	E0134	E0174	E0244	E0324	E0474	E0594
					I_N	1.9	3.1	5.0	8.8	11.7	16.3	20.6	29.4	38.4	47.0	59.0
					$I_{0,max}$	6.0	10.0	16.0	21.0	28.0	39.0	49.5	58.8	76.8	94.0	118.0
MCS	M_N	n_N	I_N	P_N	I_{max}	6.0	10.0	16.0	21.0	28.0	39.0	49.5	58.8	76.8	94.0	118.0
09F60-	2.4	6000	4.5	1.50	M_0			3.5	4.2	4.2	4.2					
					M_N			2.4	2.4	2.4	2.4					
					$M_{0,max}$			9.8	12.0	14.4	14.9					
					M_{max}			9.8	12.0	14.4	14.9					
					η_{eto}			-	-	-	-					
09H41-	3.8	4050	3.4	1.60	M_0		4.0	5.5	5.5							
					M_N		3.5	3.8	3.8							
					$M_{0,max}$		12.0	17.5	20.4							
					M_{max}		12.0	17.5	20.4							
					η_{eto}		-	-	-							
09H60-	3.0	6000	6.0	1.90	M_0				5.5	5.5	5.5	5.5				
					M_N				3.0	3.0	3.0	3.0				
					$M_{0,max}$				12.5	15.8	20.1	20.4				
					M_{max}				12.5	15.8	20.1	20.4				
					η_{eto}				-	-	-	-				
09L41-	4.5	4050	4.2	1.90	M_0			6.0	7.5	7.5						
					M_N			4.5	4.5	4.5						
					$M_{0,max}$			17.4	22.2	28.5						
					M_{max}			17.4	22.2	28.5						
					η_{eto}			-	-	-						
09L51-	3.6	5100	6.9	1.90	M_0				5.3	7.0	7.5	7.5	7.5			
					M_N				3.6	3.6	3.6	3.6	3.6			
					$M_{0,max}$				11.9	15.5	20.9	25.8	29.7			
					M_{max}				11.9	15.5	20.9	25.8	29.7			
					η_{eto}				-	-	-	-	-			
12D20-	5.5	1950	2.6	1.10	M_0	4.4	6.4									
					M_N	4.0	5.5									
					$M_{0,max}$	11.8	17.7									
					M_{max}	11.8	17.7									
					η_{eto}	-	-									
12D41-	4.3	4050	4.5	1.80	M_0			5.9	6.4							
					M_N			4.3	4.3							
					$M_{0,max}$			14.7	17.7							
					M_{max}			14.7	17.7							
					η_{eto}			-	-							
12H15-	10.0	1500	3.8	1.60	M_0		8.7	11.4								
					M_N		8.2	10.0								
					$M_{0,max}$		24.6	29.0								
					M_{max}		24.6	29.0								
					η_{eto}		-	-								
12H35-	7.5	3525	5.7	2.80	M_0			7.0	11.4	11.4	11.4					
					M_N			6.6	7.5	7.5	7.5					
					$M_{0,max}$			20.1	25.8	29.0	29.0					
					M_{max}			20.1	25.8	29.0	29.0					
					η_{eto}			-	-	-	-					

- $I...$ [A], $M...$ [Nm], $n...$ [r/min], $P...$ [kW]

MCS synchronous servo motors

Technical data



Selection tables, Servo Drives 9400 HighLine

Non-ventilated motors

- The data applies to a mains connection voltage of 3 x 400 V and an inverter switching frequency of 4 kHz.

					E94A□□	E0024	E0034	E0044	E0074	E0094	E0134	E0174	E0244	E0324	E0474	E0594					
					I _N	1.9	3.1	5.0	8.8	11.7	16.3	20.6	29.4	38.4	47.0	59.0					
					I _{0,max}	6.0	10.0	16.0	21.0	28.0	39.0	49.5	58.8	76.8	94.0	118.0					
MCS	M _N	n _N	I _N	P _N	I _{max}	6.0	10.0	16.0	21.0	28.0	39.0	49.5	58.8	76.8	94.0	118.0					
12L20-	13.5	1950	5.9	2.80	M ₀			12.1	15.0	15.0	15.0										
					M _N			11.4	13.5	13.5	13.5										
					M _{0,max}			35.5	44.6	55.7	56.4										
					M _{max}			35.5	44.6	55.7	56.4										
					η _{eto}			-	-	-	-										
12L41-	11.0	4050	10.2	4.70	M ₀				10.6	14.0	15.0	15.0	15.0								
					M _N				9.5	11.0	11.0	11.0	11.0								
					M _{0,max}				24.4	31.6	41.9	50.8	56.4								
					M _{max}				24.4	31.6	41.9	50.8	56.4								
					η _{eto}				-	-	-	-	-								
14D15-	9.2	1500	4.5	1.45	M ₀			11.0	11.0												
					M _N			9.2	9.2												
					M _{0,max}			28.3	29.0												
					M _{max}			28.3	29.0												
					η _{eto}			-	-												
14D36-	7.5	3600	7.5	2.80	M ₀				9.6	11.0	11.0										
					M _N				7.5	7.5	7.5										
					M _{0,max}				20.2	25.6	29.0										
					M _{max}				20.2	25.6	29.0										
					η _{eto}				-	-	-										
14H15-	16.0	1500	6.6	2.50	M ₀			12.4	21.0	21.0	21.0										
					M _N			12.1	16.0	16.0	16.0										
					M _{0,max}			37.1	46.6	54.8	54.8										
					M _{max}			37.1	46.6	54.8	54.8										
					η _{eto}			-	-	-	-										
14H32-	14.0	3225	11.9	4.70	M ₀					14.4	20.3	21.0	21.0								
					M _N					13.6	14.0	14.0	14.0								
					M _{0,max}					33.0	43.9	53.2	54.8								
					M _{max}					33.0	43.9	53.2	54.8								
					η _{eto}					-	-	-	-								
14L15-	23.0	1500	9.7	3.60	M ₀				20.5	27.1	28.0										
					M _N				20.9	23.0	23.0										
					M _{0,max}				48.0	61.4	77.1										
					M _{max}				48.0	61.4	77.1										
					η _{eto}				-	-	-										
14L32-	17.2	3225	15.0	5.80	M ₀						19.0	24.0	28.0	28.0	28.0						
					M _N						17.2	17.2	17.2	17.2	17.2						
					M _{0,max}						45.0	55.3	63.9	77.1	77.1						
					M _{max}						45.0	55.3	63.9	77.1	77.1						
					η _{eto}						-	-	-	-	-						
14P14-	30.0	1350	10.8	4.20	M ₀				26.7	35.2	37.0	37.0									
					M _N				24.4	30.0	30.0	30.0									
					M _{0,max}				56.1	71.7	93.3	105.1									
					M _{max}				56.1	71.7	93.3	105.1									
					η _{eto}				-	-	-	-									

- I... [A], M... [Nm], n... [r/min], P... [kW]

MCS synchronous servo motors

Technical data



Selection tables, Servo Drives 9400 HighLine

Non-ventilated motors

- The data applies to a mains connection voltage of 3 x 400 V and an inverter switching frequency of 4 kHz.

					E94A□□	E0024	E0034	E0044	E0074	E0094	E0134	E0174	E0244	E0324	E0474	E0594
					I_N	1.9	3.1	5.0	8.8	11.7	16.3	20.6	29.4	38.4	47.0	59.0
					$I_{0,max}$	6.0	10.0	16.0	21.0	28.0	39.0	49.5	58.8	76.8	94.0	118.0
MCS	M_N	n_N	I_N	P_N	I_{max}	6.0	10.0	16.0	21.0	28.0	39.0	49.5	58.8	76.8	94.0	118.0
14P32-	21.0	3225	15.6	7.10	M_0						24.8	31.4	37.0	37.0	37.0	
					M_N						21.0	21.0	21.0	21.0	21.0	
					$M_{0,max}$						52.5	64.6	74.7	92.2	105.1	
					M_{max}						52.5	64.6	74.7	92.2	105.1	
					η_{eto}						-	-	-	-	-	
19F14-	27.0	1425	8.6	4.00	M_0			28.4	32.0	32.0						
					M_N			27.0	27.0	27.0						
					$M_{0,max}$			62.1	78.9	86.0						
					M_{max}			62.1	78.9	86.0						
					η_{eto}			-	-	-						
19F30-	21.0	3000	14.0	6.60	M_0					26.3	32.0	32.0	32.0			
					M_N					21.0	21.0	21.0	21.0			
					$M_{0,max}$					56.6	70.2	81.6	86.0			
					M_{max}					56.6	70.2	81.6	86.0			
					η_{eto}					-	-	-	-			
19J14-	40.0	1425	12.3	6.00	M_0				38.9	51.0	51.0					
					M_N				37.7	40.0	40.0					
					$M_{0,max}$				85.0	114.4	129.0					
					M_{max}				85.0	114.4	129.0					
					η_{eto}				-	-	-					
19J30-	29.0	3000	18.5	9.10	M_0					27.3	34.4	49.2	51.0	51.0		
					M_N					25.6	29.0	29.0	29.0	29.0		
					$M_{0,max}$					60.8	75.9	88.9	112.9	129.0		
					M_{max}					60.8	75.9	88.9	112.9	129.0		
					η_{eto}					-	-	-	-	-		
19P14-	51.0	1350	14.3	7.20	M_0					59.6	64.0	64.0	64.0			
					M_N					51.0	51.0	51.0	51.0			
					$M_{0,max}$					128.4	159.9	186.6	190.0			
					M_{max}					128.4	159.9	186.6	190.0			
					η_{eto}					-	-	-	-			
19P30-	32.0	3000	19.0	10.00	M_0					29.9	37.8	53.9	64.0	64.0	64.0	
					M_N					27.5	32.0	32.0	32.0	32.0	32.0	
					$M_{0,max}$					65.7	83.6	98.5	126.6	152.5	187.2	
					M_{max}					65.7	83.6	98.5	126.6	152.5	187.2	
					η_{eto}					-	-	-	-	-	-	

- I... [A], M... [Nm], n... [r/min], P... [kW]

MCS synchronous servo motors

Technical data



Selection tables, Servo Drives 9400 HighLine

Non-ventilated motors

- The data applies to a mains connection voltage of 3x230V and an inverter switching frequency of 4 kHz.

					E94A□□	E0024	E0034	E0044	E0074	E0094	E0134	E0174	E0244	E0324
					I_N	1.9	3.1	5.0	8.8	11.7	16.3	20.6	29.4	38.4
					$I_{0,max}$	6.0	10.0	16.0	21.0	28.0	39.0	49.5	58.8	76.8
MCS	M_N	n_N	I_N	P_N	I_{max}	6.0	10.0	16.0	21.0	28.0	39.0	49.5	58.8	76.8
06C41L	0.6	4050	2.6	0.25	M_0	0.6	0.8							
					M_N	0.5	0.6							
					$M_{0,max}$	1.5	2.3							
					M_{max}	1.5	2.3							
					η_{eto}	-	-							
06C60L	0.5	6000	4.0	0.31	M_0		0.6	0.8	0.8					
					M_N		0.4	0.5	0.5					
					$M_{0,max}$		1.5	2.2	2.4					
					M_{max}		1.5	2.2	2.4					
					η_{eto}		-	-	-					
06F41L	1.2	4050	2.9	0.51	M_0	1.0	1.5	1.5						
					M_N	0.8	1.2	1.2						
					$M_{0,max}$	2.7	4.2	4.4						
					M_{max}	2.7	4.2	4.4						
					η_{eto}	-	-	-						
06F60L	0.9	6000	3.8	0.57	M_0		1.2	1.5	1.5					
					M_N		0.8	0.9	0.9					
					$M_{0,max}$		3.1	4.3	4.4					
					M_{max}		3.1	4.3	4.4					
					η_{eto}		-	-	-					
06I41L	1.5	4050	3.2	0.64	M_0		2.0	2.0						
					M_N		1.5	1.5						
					$M_{0,max}$		5.4	6.2						
					M_{max}		5.4	6.2						
					η_{eto}		-	-						
06I60L	1.2	6000	3.8	0.75	M_0		1.5	2.0						
					M_N		1.0	1.2						
					$M_{0,max}$		4.4	6.2						
					M_{max}		4.4	6.2						
					η_{eto}		-	-						
09D41L	2.3	4050	4.6	1.00	M_0			3.1	3.3					
					M_N			2.3	2.3					
					$M_{0,max}$			8.0	9.5					
					M_{max}			8.0	9.5					
					η_{eto}			-	-					
09D60L	1.8	6000	7.0	1.10	M_0				2.8	3.3	3.3			
					M_N				1.8	1.8	1.8			
					$M_{0,max}$				5.7	7.3	9.5			
					M_{max}				5.7	7.3	9.5			
					η_{eto}				-	-	-			
09F38L	3.1	3750	5.0	1.20	M_0			3.5	4.2	4.2	4.2			
					M_N			3.1	3.1	3.1	3.1			
					$M_{0,max}$			9.8	12.0	13.8	15.0			
					M_{max}			9.8	12.0	13.8	15.0			
					η_{eto}			-	-	-	-			

- $I...$ [A], $M...$ [Nm], $n...$ [r/min], $P...$ [kW]

MCS synchronous servo motors

Technical data



Selection tables, Servo Drives 9400 HighLine

Non-ventilated motors

- The data applies to a mains connection voltage of 3x230V and an inverter switching frequency of 4 kHz.

					E94A□□	E0024	E0034	E0044	E0074	E0094	E0134	E0174	E0244	E0324
					I_N	1.9	3.1	5.0	8.8	11.7	16.3	20.6	29.4	38.4
					$I_{0,max}$	6.0	10.0	16.0	21.0	28.0	39.0	49.5	58.8	76.8
MCS	M_N	n_N	I_N	P_N	I_{max}	6.0	10.0	16.0	21.0	28.0	39.0	49.5	58.8	76.8
09F60L	2.4	6000	7.9	1.50	M_0				3.5	4.2	4.2	4.2	4.2	
					M_N				2.4	2.4	2.4	2.4	2.4	
					$M_{0,max}$				7.8	9.8	12.6	14.5	15.0	
					M_{max}				7.8	9.8	12.6	14.5	15.0	
					η_{eto}				-	-	-	-	-	
09H41L	3.8	4050	6.8	1.60	M_0				5.5	5.3	5.5	5.5		
					M_N				3.8	3.0	3.8	3.8		
					$M_{0,max}$				12.4	11.8	19.7	20.0		
					M_{max}				12.4	11.8	19.7	20.0		
					η_{eto}				-	-	-	-		
09H60L	3.0	6000	8.0	1.90	M_0				4.0	5.5	5.5	5.5	5.5	
					M_N				3.0	3.8	3.0	3.0	3.0	
					$M_{0,max}$				9.2	15.6	15.4	18.3	20.0	
					M_{max}				9.2	15.6	15.4	18.3	20.0	
					η_{eto}				-	-	-	-	-	
09L41L	4.5	4050	8.4	1.90	M_0				5.3	7.0	7.5	7.5	7.5	7.5
					M_N				4.5	4.5	4.5	4.5	4.5	4.5
					$M_{0,max}$				11.9	15.5	20.9	25.8	29.7	31.9
					M_{max}				11.9	15.5	20.9	25.8	29.7	31.9
					η_{eto}				-	-	-	-	-	-
12D20L	5.5	1950	5.2	1.10	M_0			5.9	6.4					
					M_N			5.3	5.5					
					$M_{0,max}$			14.9	17.7					
					M_{max}			14.9	17.7					
					η_{eto}			-	-					
12D41L	4.3	4050	8.8	1.80	M_0				5.3	6.4	6.4	6.4		
					M_N				4.3	4.3	4.3	4.3		
					$M_{0,max}$				10.6	13.6	17.7	17.9		
					M_{max}				10.6	13.6	17.7	17.9		
					η_{eto}				-	-	-	-		
12H15L	10.0	1500	7.6	1.60	M_0				11.4	11.4	10.0			
					M_N				10.0	10.0	11.4			
					$M_{0,max}$				25.8	29.0	29.0			
					M_{max}				25.8	29.0	29.0			
					η_{eto}				-	-	-			
12H30L	8.0	3000	10.5	2.50	M_0				7.4	9.8	11.4			
					M_N				6.7	8.0	8.0			
					$M_{0,max}$				16.4	21.5	29.0			
					M_{max}				16.4	21.5	29.0			
					η_{eto}				-	-	-			
12L20L	13.5	1950	11.8	2.80	M_0				10.6	14.0	15.0	15.0	15.0	
					M_N				10.1	13.3	13.5	13.5	13.5	
					$M_{0,max}$				24.4	31.5	41.8	50.5	56.0	
					M_{max}				24.4	31.5	41.8	50.5	56.0	
					η_{eto}				-	-	-	-	-	

- $I...$ [A], $M...$ [Nm], $n...$ [r/min], $P...$ [kW]

MCS synchronous servo motors

Technical data



Selection tables, Servo Drives 9400 HighLine

Forced ventilated IP54 motors

- The data applies to a mains connection voltage of 3 x 400 V and an inverter switching frequency of 4 kHz.

					E94A□□	E0024	E0034	E0044	E0074	E0094	E0134	E0174	E0244	E0324	E0474	E0594
					I_N	1.9	3.1	5.0	8.8	11.7	16.3	20.6	29.4	38.4	47.0	59.0
					$I_{0,max}$	6.0	10.0	16.0	21.0	28.0	39.0	49.5	58.8	76.8	94.0	118.0
MCS	M_N	n_N	I_N	P_N	I_{max}	6.0	10.0	16.0	21.0	28.0	39.0	49.5	58.8	76.8	94.0	118.0
12D17-	7.0	1650	3.0	1.20	M_0	4.4	7.3									
					M_N	4.0	7.0									
					$M_{0,max}$	11.8	17.7									
					M_{max}	11.8	17.7									
					η_{eto}	-	-									
12D35-	6.0	3525	5.6	2.20	M_0			5.9	7.5							
					M_N			5.4	6.0							
					$M_{0,max}$			14.7	17.7							
					M_{max}			14.7	17.7							
					η_{eto}			-	-							
12H14-	12.0	1350	4.1	1.70	M_0		8.7	12.8								
					M_N		8.2	12.0								
					$M_{0,max}$		24.6	29.0								
					M_{max}		24.6	29.0								
					η_{eto}		-	-								
12H34-	10.5	3375	7.5	3.70	M_0			7.0	12.8	12.8	12.8					
					M_N			6.6	10.5	10.5	10.5					
					$M_{0,max}$			20.1	25.8	29.0	29.0					
					M_{max}			20.1	25.8	29.0	29.0					
					η_{eto}			-	-	-	-					
12L17-	17.0	1650	6.7	2.90	M_0			12.1	19.0	19.0	19.0					
					M_N			11.4	17.0	17.0	17.0					
					$M_{0,max}$			35.5	44.6	55.7	56.4					
					M_{max}			35.5	44.6	55.7	56.4					
					η_{eto}			-	-	-	-					
12L39-	14.0	3900	11.7	5.70	M_0				10.6	15.3	19.0	19.0	19.0			
					M_N				9.5	13.9	14.0	14.0	14.0			
					$M_{0,max}$				24.4	31.6	41.9	50.8	56.4			
					M_{max}				24.4	31.6	41.9	50.8	56.4			
					η_{eto}				-	-	-	-	-			
14D14-	12.0	1350	5.4	1.70	M_0			11.0	12.5							
					M_N			11.0	12.0							
					$M_{0,max}$			28.3	29.0							
					M_{max}			28.3	29.0							
					η_{eto}			-	-							
14D30-	10.5	3000	9.7	3.30	M_0				9.6	12.5	12.5					
					M_N				9.5	10.5	10.5					
					$M_{0,max}$				20.2	25.6	29.0					
					M_{max}				20.2	25.6	29.0					
					η_{eto}				-	-	-					
14H12-	23.5	1200	8.3	3.00	M_0			12.4	24.1	25.5	25.5					
					M_N			12.1	23.5	23.5	23.5					
					$M_{0,max}$			37.1	46.6	54.8	54.8					
					M_{max}			37.1	46.6	54.8	54.8					
					η_{eto}			-	-	-	-					

- $I...$ [A], $M...$ [Nm], $n...$ [r/min], $P...$ [kW]

MCS synchronous servo motors

Technical data

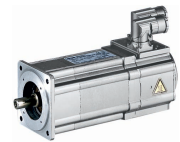

Selection tables, Servo Drives 9400 HighLine

Forced ventilated IP54 motors

- The data applies to a mains connection voltage of 3 x 400 V and an inverter switching frequency of 4 kHz.

					E94A□□	E0024	E0034	E0044	E0074	E0094	E0134	E0174	E0244	E0324	E0474	E0594
					I _N	1.9	3.1	5.0	8.8	11.7	16.3	20.6	29.4	38.4	47.0	59.0
					I _{0,max}	6.0	10.0	16.0	21.0	28.0	39.0	49.5	58.8	76.8	94.0	118.0
MCS	M _N	n _N	I _N	P _N	I _{max}	6.0	10.0	16.0	21.0	28.0	39.0	49.5	58.8	76.8	94.0	118.0
14H28-	20.5	2775	15.0	6.00	M ₀					16.1	20.5	25.5	25.5			
					M _N					15.9	20.5	20.5	20.5			
					M _{0,max}						33.0	43.9	53.2	54.8		
					M _{max}							33.0	43.9	53.2	54.8	
					η _{eto}							-	-	-	-	
14L14-	30.5	1350	11.8	4.30	M ₀			20.5	30.0	34.5						
					M _N			20.5	30.0	30.5						
					M _{0,max}			48.0	61.4	77.1						
					M _{max}			48.0	61.4	77.1						
					η _{eto}			-	-	-						
14L30-	25.5	3000	20.8	8.00	M ₀					21.0	26.6	34.5	34.5	34.5		
					M _N					20.0	25.3	25.5	25.5	25.5		
					M _{0,max}					45.0	55.3	63.9	77.1	77.1		
					M _{max}					45.0	55.3	63.9	77.1	77.1		
					η _{eto}						-	-	-	-	-	
14P11-	42.0	1050	13.4	4.60	M ₀			26.7	36.4	43.5	43.5					
					M _N			24.4	36.4	42.0	42.0					
					M _{0,max}			56.1	71.7	93.3	105.1					
					M _{max}			56.1	71.7	93.3	105.1					
					η _{eto}			-	-	-	-					
14P26-	33.0	2625	21.9	9.10	M ₀					24.8	31.4	43.5	43.5	43.5		
					M _N					24.6	31.0	33.0	33.0	33.0		
					M _{0,max}					52.5	64.6	74.7	92.2	105.1		
					M _{max}					52.5	64.6	74.7	92.2	105.1		
					η _{eto}						-	-	-	-	-	
19F12-	38.0	1200	11.3	4.80	M ₀			29.9	39.5	41.5						
					M _N			29.3	38.0	38.0						
					M _{0,max}			62.1	78.9	86.0						
					M _{max}			62.1	78.9	86.0						
					η _{eto}			-	-	-						
19F29-	32.5	2850	20.1	9.70	M ₀					26.3	34.9	41.5	41.5			
					M _N					26.0	32.5	32.5	32.5			
					M _{0,max}					56.6	70.2	81.6	86.0			
					M _{max}					56.6	70.2	81.6	86.0			
					η _{eto}						-	-	-	-		
19J12-	62.5	1200	18.3	7.90	M ₀					56.6	70.5					
					M _N					55.7	62.5					
					M _{0,max}					114.4	129.0					
					M _{max}					114.4	129.0					
					η _{eto}						-	-				
19J29-	50.5	2850	31.0	15.10	M ₀							49.2	66.7	70.5		
					M _N							47.9	50.5	50.5		
					M _{0,max}							88.9	112.9	129.0		
					M _{max}							88.9	112.9	129.0		
					η _{eto}							-	-	-		

- I... [A], M... [Nm], n... [r/min], P... [kW]

MCS synchronous servo motors

Technical data



Selection tables, Servo Drives 9400 HighLine

Forced ventilated IP54 motors

- The data applies to a mains connection voltage of 3 x 400 V and an inverter switching frequency of 4 kHz.

					E94A□□	E0024	E0034	E0044	E0074	E0094	E0134	E0174	E0244	E0324	E0474	E0594
					I_N	1.9	3.1	5.0	8.8	11.7	16.3	20.6	29.4	38.4	47.0	59.0
					$I_{0,max}$	6.0	10.0	16.0	21.0	28.0	39.0	49.5	58.8	76.8	94.0	118.0
MCS	M_N	n_N	I_N	P_N	I_{max}	6.0	10.0	16.0	21.0	28.0	39.0	49.5	58.8	76.8	94.0	118.0
19P12-	72.0	1200	21.3	9.00	M_0							79.1	86.0	86.0		
					M_N						69.6	72.0	72.0			
					$M_{0,max}$						159.9	186.6	190.0			
					M_{max}						159.9	186.6	190.0			
					η_{eto}											
19P29-	53.0	2850	29.5	15.80	M_0								56.5	73.9	86.0	86.0
					M_N							52.8	53.0	53.0	53.0	
					$M_{0,max}$							98.5	126.6	152.5	187.2	
					M_{max}							98.5	126.6	152.5	187.2	
					η_{eto}											

- $I...$ [A], $M...$ [Nm], $n...$ [r/min], $P...$ [kW]

MCS synchronous servo motors

Technical data



MCS synchronous servo motors

Technical data



Selection tables, Inverter Drives 8400 TopLine

Non-ventilated motors

- The data applies to a mains connection voltage of 3 x 400 V and an inverter switching frequency of 8 kHz.

					E84AVTC	□3714	□5514	□7514	□1124	□1524	□2224	□3024
					I_N	1.3	1.8	2.4	3.2	3.9	5.9	7.3
					$I_{0,max}$	2.0	2.7	3.6	4.8	5.9	8.4	11.0
MCS	M_N	n_N	I_N	P_N	I_{max}	2.6	3.6	4.8	6.4	7.8	11.8	14.6
06C41-	0.6	4050	1.3	0.25	M_0	0.8	0.8	0.8	0.8	0.8		
					M_N	0.6	0.6	0.6	0.6	0.6		
					$M_{0,max}$	1.4	1.7	2.3	2.4	2.4		
					M_{max}	1.4	1.7	2.3	2.4	2.4		
					η_{eto}	-	-	-	-	-		
06C60-	0.5	6000	2.4	0.31	M_0			0.8	0.8	0.8	0.8	0.8
					M_N			0.5	0.5	0.5	0.5	0.5
					$M_{0,max}$			1.3	1.6	2.0	2.4	2.4
					M_{max}			1.3	1.6	2.0	2.4	2.4
					η_{eto}			-	-	-	-	-
06F41-	1.2	4050	1.5	0.51	M_0	1.3	1.5	1.5	1.5	1.5		
					M_N	1.0	1.2	1.2	1.2	1.2		
					$M_{0,max}$	2.3	3.2	4.3	4.4	4.4		
					M_{max}	2.3	3.2	4.3	4.4	4.4		
					η_{eto}	-	-	-	-	-		
06F60-	0.9	6000	2.5	0.57	M_0			1.2	1.5	1.5	1.5	1.5
					M_N			0.9	0.9	0.9	0.9	0.9
					$M_{0,max}$			2.1	3.3	4.0	4.4	4.4
					M_{max}			2.1	3.3	4.0	4.4	4.4
					η_{eto}			-	-	-	-	-
06I41-	1.5	4050	1.6	0.64	M_0	1.6	2.0	2.0	2.0	2.0		
					M_N	1.2	1.5	1.5	1.5	1.5		
					$M_{0,max}$	2.9	4.0	5.3	6.2	6.2		
					M_{max}	2.9	4.0	5.3	6.2	6.2		
					η_{eto}	-	-	-	-	-		
06I60-	1.2	6000	2.9	0.75	M_0				2.0	2.0	2.0	2.0
					M_N				1.2	1.2	1.2	1.2
					$M_{0,max}$				3.6	4.4	5.7	5.7
					M_{max}				3.6	4.4	5.7	5.7
					η_{eto}				-	-	-	-
09D41-	2.3	4050	2.3	1.00	M_0		2.2	3.1	3.3	3.3	3.3	3.3
					M_N		1.7	2.3	2.3	2.3	2.3	2.3
					$M_{0,max}$		4.0	5.3	6.7	8.2	9.4	9.4
					M_{max}		4.0	5.3	6.7	8.2	9.4	9.4
					η_{eto}		-	-	-	-	-	-
09D60-	1.8	6000	3.8	1.10	M_0				2.0	2.4	3.3	3.3
					M_N				1.5	1.8	1.8	1.8
					$M_{0,max}$				3.5	4.2	6.3	7.8
					M_{max}				3.5	4.2	6.3	7.8
					η_{eto}				-	-	-	-
09F38-	3.1	3750	2.5	1.20	M_0			3.4	4.2	4.2	4.2	4.2
					M_N			3.0	3.1	3.1	3.1	3.1
					$M_{0,max}$			6.6	8.4	10.2	12.0	12.0
					M_{max}			6.6	8.4	10.2	12.0	12.0
					η_{eto}			-	-	-	-	-

- $I...$ [A], $M...$ [Nm], $n...$ [r/min], $P...$ [kW]

6.11

MCS synchronous servo motors

Technical data



Selection tables, Inverter Drives 8400 TopLine

Non-ventilated motors

- The data applies to a mains connection voltage of 3 x 400 V and an inverter switching frequency of 8 kHz.

□4024	□5524	□7524	□1134	□1534	□1834	□2234	□3034	E84AVTC					
9.5	13.0	16.5	23.5	32.0	39.0	47.0	61.0	I_N	P_N	I_N	n_N	M_N	MCS
14.3	19.5	26.4	32.9	43.2	60.0	70.5	91.5	$I_{0,max}$					
19.0	26.0	33.0	47.0	64.0	78.0	94.0	122.0	I_{max}	0.25	1.3	4050	0.6	06C41-
								M_0					
								M_N					
								$M_{0,max}$					
								M_{max}					
								n_{eto}	0.31	2.4	6000	0.5	06C60-
								M_0					
								M_N					
								$M_{0,max}$					
								M_{max}					
								n_{eto}	0.51	1.5	4050	1.2	06F41-
								M_0					
								M_N					
								$M_{0,max}$					
								M_{max}					
								n_{eto}	0.57	2.5	6000	0.9	06F60-
								M_0					
								M_N					
								$M_{0,max}$					
								M_{max}					
								n_{eto}	0.64	1.6	4050	1.5	06I41-
								M_0					
								M_N					
								$M_{0,max}$					
								M_{max}					
								n_{eto}	0.75	2.9	6000	1.2	06I60-
								M_0					
								M_N					
								$M_{0,max}$					
								M_{max}					
								n_{eto}	1.00	2.3	4050	2.3	09D41-
								M_0					
								M_N					
								$M_{0,max}$					
								M_{max}					
								n_{eto}	1.10	3.8	6000	1.8	09D60-
3.3	3.3							M_0					
1.8	1.8							M_N					
9.1	9.3							$M_{0,max}$					
9.1	9.3							M_{max}					
-	-							n_{eto}	1.20	2.5	3750	3.1	09F38-
								M_0					
								M_N					
								$M_{0,max}$					
								M_{max}					
								n_{eto}					

- $I...$ [A], $M...$ [Nm], $n...$ [r/min], $P...$ [kW]

MCS synchronous servo motors

Technical data



Selection tables, Inverter Drives 8400 TopLine

Non-ventilated motors

- The data applies to a mains connection voltage of 3 x 400 V and an inverter switching frequency of 8 kHz.

					E84AVTC	□3714	□5514	□7514	□1124	□1524	□2224	□3024
					I_N	1.3	1.8	2.4	3.2	3.9	5.9	7.3
					$I_{0,max}$	2.0	2.7	3.6	4.8	5.9	8.4	11.0
MCS	M_N	n_N	I_N	P_N	I_{max}	2.6	3.6	4.8	6.4	7.8	11.8	14.6
09F60-	2.4	6000	4.5	1.50	M_0						4.2	4.2
					M_N						2.4	2.4
					$M_{0,max}$						7.8	9.6
					M_{max}						7.8	9.6
					η_{eto}						-	-
09H41-	3.8	4050	3.4	1.60	M_0				4.7	5.0	5.5	5.5
					M_N				3.6	3.8	3.8	3.8
					$M_{0,max}$				8.1	9.9	14.0	17.4
					M_{max}				8.1	9.9	14.0	17.4
					η_{eto}				-	-	-	-
09H60-	3.0	6000	6.0	1.90	M_0						4.4	4.5
					M_N						3.0	3.0
					$M_{0,max}$						7.5	9.3
					M_{max}						7.5	9.3
					η_{eto}						-	-
09L41-	4.5	4050	4.2	1.90	M_0				3.9	4.7	7.5	7.5
					M_N				3.4	4.2	4.5	4.5
					$M_{0,max}$				7.3	8.9	13.1	16.3
					M_{max}				7.3	8.9	13.1	16.3
					η_{eto}				-	-	-	-
09L51-	3.6	5100	6.9	1.90	M_0							4.2
					M_N							3.6
					$M_{0,max}$							8.3
					M_{max}							8.3
					η_{eto}							-
12D20-	5.5	1950	2.6	1.10	M_0			5.7	6.4	6.4	6.4	6.4
					M_N			5.1	5.5	5.5	5.5	5.5
					$M_{0,max}$			9.6	12.6	15.3	17.7	17.7
					M_{max}			9.6	12.6	15.3	17.7	17.7
					η_{eto}			-	-	-	-	-
12D41-	4.3	4050	4.5	1.80	M_0				3.8	4.6	6.4	6.4
					M_N				3.0	3.7	4.3	4.3
					$M_{0,max}$				6.4	7.8	11.4	14.0
					M_{max}				6.4	7.8	11.4	14.0
					η_{eto}				-	-	-	-
12H15-	10.0	1500	3.8	1.60	M_0				9.2	10.9	11.4	11.4
					M_N				8.4	10.0	10.0	10.0
					$M_{0,max}$				16.4	20.0	29.0	29.0
					M_{max}				16.4	20.0	29.0	29.0
					η_{eto}				-	-	-	-
12H35-	7.5	3525	5.7	2.80	M_0						9.8	9.8
					M_N						7.5	7.5
					$M_{0,max}$						15.2	18.8
					M_{max}						15.2	18.8
					η_{eto}						-	-

- $I...$ [A], $M...$ [Nm], $n...$ [r/min], $P...$ [kW]

6.11

MCS synchronous servo motors

Technical data



Selection tables, Inverter Drives 8400 TopLine

Non-ventilated motors

- The data applies to a mains connection voltage of 3 x 400 V and an inverter switching frequency of 8 kHz.

□4024	□5524	□7524	□1134	□1534	□1834	□2234	□3034	E84AVTC						
9.5	13.0	16.5	23.5	32.0	39.0	47.0	61.0	I_N		P_N	I_N	n_N	M_N	MCS
14.3	19.5	26.4	32.9	43.2	60.0	70.5	91.5	$I_{0,max}$						
19.0	26.0	33.0	47.0	64.0	78.0	94.0	122.0	I_{max}						
4.2	4.2							M_0	1.50	4.5	6000	2.4	09F60-	
2.4	2.4							M_N						
11.1	11.4							$M_{0,max}$						
11.1	11.4							M_{max}	1.60	3.4	4050	3.8	09H41-	
-	-							n_{eto}						
5.5	5.5							M_0						
3.8	3.8							M_N	1.90	6.0	6000	3.0	09H60-	
19.6	20.1							$M_{0,max}$						
19.6	20.1							M_{max}						
-	-							n_{eto}	1.90	4.2	4050	4.5	09L41-	
5.5	5.5							M_0						
3.0	3.0							M_N						
11.4	11.7							$M_{0,max}$	1.90	6.9	5100	3.6	09L51-	
11.4	11.7							M_{max}						
-	-							n_{eto}						
7.5	7.5							M_0	1.10	2.6	1950	5.5	12D20-	
4.5	4.5							M_N						
20.3	20.8							$M_{0,max}$						
20.3	20.8							M_{max}	1.80	4.5	4050	4.3	12D41-	
-	-							n_{eto}						
7.5	7.5	7.5	7.5					M_0						
3.6	3.6	3.6	3.6					M_N	1.60	3.8	1500	10.0	12H15-	
10.8	19.1	19.1	19.1					$M_{0,max}$						
10.8	19.1	19.1	19.1					M_{max}						
-	-	-	-					n_{eto}	2.80	5.7	3525	7.5	12H35-	
								M_0						
								M_N						
								$M_{0,max}$	1.10	2.6	1950	5.5	12D20-	
								M_{max}						
								n_{eto}						
6.4	6.4							M_0	1.80	4.5	4050	4.3	12D41-	
4.3	4.3							M_N						
16.9	17.3							$M_{0,max}$						
16.9	17.3							M_{max}	1.60	3.8	1500	10.0	12H15-	
-	-							n_{eto}						
11.4	11.4							M_0						
10.0	10.0							M_N	2.80	5.7	3525	7.5	12H35-	
28.3	29.0							$M_{0,max}$						
28.3	29.0							M_{max}						
-	-							n_{eto}	2.80	5.7	3525	7.5	12H35-	
11.4	11.4							M_0						
7.5	7.5							M_N						
23.5	24.1							$M_{0,max}$	2.80	5.7	3525	7.5	12H35-	
23.5	24.1							M_{max}						
-	-							n_{eto}						

- $I...$ [A], $M...$ [Nm], $n...$ [r/min], $P...$ [kW]

MCS synchronous servo motors

Technical data



Selection tables, Inverter Drives 8400 TopLine

Non-ventilated motors

- The data applies to a mains connection voltage of 3 x 400 V and an inverter switching frequency of 8 kHz.

					E84AVTC	□3714	□5514	□7514	□1124	□1524	□2224	□3024
					I_N	1.3	1.8	2.4	3.2	3.9	5.9	7.3
					$I_{0,max}$	2.0	2.7	3.6	4.8	5.9	8.4	11.0
MCS	M_N	n_N	I_N	P_N	I_{max}	2.6	3.6	4.8	6.4	7.8	11.8	14.6
12L20-	13.5	1950	5.9	2.80	M_0						15.0	15.0
					M_N						13.5	13.5
					$M_{0,max}$						27.4	33.9
					M_{max}						27.4	33.9
					η_{eto}						-	-
12L41-	11.0	4050	10.2	4.70	M_0							
					M_N							
					$M_{0,max}$							
					M_{max}							
					η_{eto}							
14D15-	9.2	1500	4.5	1.45	M_0				7.0	8.5	11.0	11.0
					M_N				6.6	8.0	9.2	9.2
					$M_{0,max}$				13.1	16.0	22.7	28.1
					M_{max}				13.1	16.0	22.7	28.1
					η_{eto}				-	-	-	-
14D36-	7.5	3600	7.5	2.80	M_0							8.0
					M_N							7.3
					$M_{0,max}$							15.2
					M_{max}							15.2
					η_{eto}							-
14H15-	16.0	1500	6.6	2.50	M_0							17.3
					M_N							16.0
					$M_{0,max}$							35.3
					M_{max}							35.3
					η_{eto}							-
14H32-	14.0	3225	11.9	4.70	M_0							
					M_N							
					$M_{0,max}$							
					M_{max}							
					η_{eto}							
14L15-	23.0	1500	9.7	3.60	M_0							
					M_N							
					$M_{0,max}$							
					M_{max}							
					η_{eto}							
14L32-	17.2	3225	15.0	5.80	M_0							
					M_N							
					$M_{0,max}$							
					M_{max}							
					η_{eto}							
14P14-	30.0	1350	10.8	4.20	M_0							
					M_N							
					$M_{0,max}$							
					M_{max}							
					η_{eto}							

- $I...$ [A], $M...$ [Nm], $n...$ [r/min], $P...$ [kW]

MCS synchronous servo motors

Technical data



Selection tables, Inverter Drives 8400 TopLine

Non-ventilated motors

- The data applies to a mains connection voltage of 3 x 400 V and an inverter switching frequency of 8 kHz.

□4024	□5524	□7524	□1134	□1534	□1834	□2234	□3034	E84AVTC					
9.5	13.0	16.5	23.5	32.0	39.0	47.0	61.0	I_N	2.80	5.9	1950	13.5	12L20-
14.3	19.5	26.4	32.9	43.2	60.0	70.5	91.5	$I_{0,max}$					
19.0	26.0	33.0	47.0	64.0	78.0	94.0	122.0	I_{max}					
15.0	15.0							M_0					
13.5	13.5							M_N					
40.8	41.9							$M_{0,max}$	4.70	10.2	4050	11.0	12L41-
40.8	41.9							M_{max}					
-	-							n_{eto}					
14.0	15.0	15.0	15.0	15.0				M_0					
10.2	11.0	11.0	11.0	11.0				M_N					
22.2	30.4	35.5	35.5	35.5				$M_{0,max}$	1.45	4.5	1500	9.2	14D15-
22.2	30.4	49.6	49.6	49.6				M_{max}					
-	-	-	-	-				n_{eto}					
11.0	11.0							M_0					
9.2	9.2							M_N					
28.3	29.0							$M_{0,max}$	2.80	7.5	3600	7.5	14D36-
28.3	29.0							M_{max}					
-	-							n_{eto}					
11.0	11.0	11.0	11.0					M_0					
7.5	7.5	7.5	7.5					M_N					
21.0	21.0							$M_{0,max}$	2.50	6.6	1500	16.0	14H15-
16.0	16.0							M_N					
42.8	43.9							$M_{0,max}$					
42.8	43.9							M_{max}					
-	-							n_{eto}					
12.9	16.2	21.0	21.0	21.0				M_0	4.70	11.9	3225	14.0	14H32-
11.2	14.0	14.0	14.0	14.0				M_N					
23.2	31.7	37.1	37.1	37.1				$M_{0,max}$					
23.2	31.7	51.9	51.9	51.9				M_{max}					
-	-	-	-	-				n_{eto}					
27.4	28.0	28.0	28.0					M_0	3.60	9.7	1500	23.0	14L15-
22.5	23.0	23.0	23.0					M_N					
43.8	52.9	52.9	52.9					$M_{0,max}$					
43.8	60.0	73.8	73.8					M_{max}					
-	-	-	-					n_{eto}					
	15.2	27.4	27.4	28.0	28.0	28.0		M_0	5.80	15.0	3225	17.2	14L32-
	14.9	17.2	17.2	17.2	17.2	17.2		M_N					
	31.3	39.7	52.9	52.9	52.9	52.9		$M_{0,max}$					
	31.3	57.6	73.9	73.9	73.9	73.9		M_{max}					
	-	-	-	-	-	-		n_{eto}					
32.5	37.0	37.0	37.0	37.0				M_0	4.20	10.8	1350	30.0	14P14-
26.4	30.0	30.0	30.0	30.0				M_N					
51.2	70.0	80.0	80.0	80.0				$M_{0,max}$					
51.2	70.0	105.1	105.1	105.1				M_{max}					
-	-	-	-	-				n_{eto}					

- $I...$ [A], $M...$ [Nm], $n...$ [r/min], $P...$ [kW]

MCS synchronous servo motors

Technical data



Selection tables, Inverter Drives 8400 TopLine

Non-ventilated motors

- The data applies to a mains connection voltage of 3 x 400 V and an inverter switching frequency of 8 kHz.

					E84AVTC	□3714	□5514	□7514	□1124	□1524	□2224	□3024	
					I_N	1.3	1.8	2.4	3.2	3.9	5.9	7.3	
					$I_{0,max}$	2.0	2.7	3.6	4.8	5.9	8.4	11.0	
MCS	M_N	n_N	I_N	P_N	I_{max}	2.6	3.6	4.8	6.4	7.8	11.8	14.6	
14P32-	21.0	3225	15.6	7.10	M_0								
					M_N								
					$M_{0,max}$								
					M_{max}								
					η_{eto}								
19F14-	27.0	1425	8.6	4.00	M_0							23.6	
					M_N								22.9
					$M_{0,max}$								45.9
					M_{max}								45.9
					η_{eto}								-
19F30-	21.0	3000	14.0	6.60	M_0								
					M_N								
					$M_{0,max}$								
					M_{max}								
					η_{eto}								
19J14-	40.0	1425	12.3	6.00	M_0								
					M_N								
					$M_{0,max}$								
					M_{max}								
					η_{eto}								
19J30-	29.0	3000	18.5	9.10	M_0								
					M_N								
					$M_{0,max}$								
					M_{max}								
					η_{eto}								
19P14-	51.0	1350	14.3	7.20	M_0								
					M_N								
					$M_{0,max}$								
					M_{max}								
					η_{eto}								
19P30-	32.0	3000	19.0	10.00	M_0								
					M_N								
					$M_{0,max}$								
					M_{max}								
					η_{eto}								

- $I...$ [A], $M...$ [Nm], $n...$ [r/min], $P...$ [kW]

MCS synchronous servo motors

Technical data



Selection tables, Inverter Drives 8400 TopLine

Non-ventilated motors

- The data applies to a mains connection voltage of 3 x 400 V and an inverter switching frequency of 8 kHz.

□4024	□5524	□7524	□1134	□1534	□1834	□2234	□3034	E84AVTC						
9.5	13.0	16.5	23.5	32.0	39.0	47.0	61.0	I_N		P_N	I_N	n_N	M_N	MCS
14.3	19.5	26.4	32.9	43.2	60.0	70.5	91.5	$I_{0,max}$						
19.0	26.0	33.0	47.0	64.0	78.0	94.0	122.0	I_{max}						
	19.8	35.8	35.8	37.0	37.0	37.0		M_0	7.10	15.6	3225	21.0	14P32-	
	17.5	21.0	21.0	21.0	21.0	21.0		M_N						
	36.5	46.3	61.8	61.8	61.8	61.8		$M_{0,max}$						
	36.5	67.3	86.4	86.4	86.4	86.4		M_{max}						
	-	-	-	-	-	-		n_{eto}						
32.0	32.0	32.0	32.0					M_0	4.00	8.6	1425	27.0	19F14-	
27.0	27.0	27.0	27.0					M_N						
56.7	68.3	68.3	68.3					$M_{0,max}$						
56.7	77.6	86.0	86.0					M_{max}						
-	-	-	-					n_{eto}						
	21.0	32.0	32.0	32.0				M_0	6.60	14.0	3000	21.0	19F30-	
	19.5	21.0	21.0	21.0				M_N						
	47.2	47.2	47.2	47.2				$M_{0,max}$						
	38.9	68.3	68.3	68.3				M_{max}						
	-	-	-	-				n_{eto}						
	43.6	51.0	51.0	51.0				M_0	6.00	12.3	1425	40.0	19J14-	
	40.0	40.0	40.0	40.0				M_N						
	81.1	96.0	96.0	96.0				$M_{0,max}$						
	81.1	129.0	129.0	129.0				M_{max}						
	-	-	-	-				n_{eto}						
			39.3	51.0	51.0	51.0	51.0	M_0	9.10	18.5	3000	29.0	19J30-	
			29.0	29.0	29.0	29.0	29.0	M_N						
			73.6	79.5	79.5	79.5	79.5	$M_{0,max}$						
			110.4	127.6	127.6	127.6	127.6	M_{max}						
			-	-	-	-	-	n_{eto}						
	47.5	64.0	64.0	64.0				M_0	7.20	14.3	1350	51.0	19P14-	
	46.4	51.0	51.0	51.0				M_N						
	92.7	106.7	106.7	106.7				$M_{0,max}$						
	92.7	155.5	155.5	155.5				M_{max}						
	-	-	-	-				n_{eto}						
			43.1	58.7	64.0	64.0	64.0	M_0	10.00	19.0	3000	32.0	19P30-	
			32.0	32.0	32.0	32.0	32.0	M_N						
			79.2	87.6	87.6	87.6	87.6	$M_{0,max}$						
			118.6	144.3	144.3	144.3	144.3	M_{max}						
			-	-	-	-	-	n_{eto}						

- $I...$ [A], $M...$ [Nm], $n...$ [r/min], $P...$ [kW]

MCS synchronous servo motors

Technical data



Selection tables, Inverter Drives 8400 TopLine

Forced ventilated IP54 motors

- The data applies to a mains connection voltage of 3 x 400 V and an inverter switching frequency of 8 kHz.

					E84AVTC	□1124	□1524	□2224	□3024	□4024	□5524	□7524	□1134	□1534	□1834	□2234	□3034			
					I_N	3.2	3.9	5.9	7.3	9.5	13.0	16.5	23.5	32.0	39.0	47.0	61.0			
					$I_{0,max}$	4.8	5.9	8.4	11.0	14.3	19.5	26.4	32.9	43.2	60.0	70.5	91.5			
MCS	M_N	n_N	I_N	P_N	I_{max}	6.4	7.8	11.8	14.6	19.0	26.0	33.0	47.0	64.0	78.0	94.0	122.0			
12D17-	7.0	1650	3.0	1.20	M_0	7.5	7.5	7.5	7.5											
					M_N	7.0	7.0	7.0	7.0											
					$M_{0,max}$	12.6	15.3	17.7	17.7											
					M_{max}	12.6	15.3	17.7	17.7											
					η_{eto}	-	-	-	-											
12D35-	6.0	3525	5.6	2.20	M_0		4.6	7.5	7.5	7.5	7.5									
					M_N		3.7	6.0	6.0	6.0	6.0									
					$M_{0,max}$		7.8	11.4	14.0	16.9	17.3									
					M_{max}		7.8	11.4	14.0	16.9	17.3									
					η_{eto}		-	-	-	-	-									
12H14-	12.0	1350	4.1	1.70	M_0	8.9	10.9	12.8	12.8	12.8	12.8									
					M_N	8.5	10.3	12.0	12.0	12.0	12.0									
					$M_{0,max}$	16.4	20.0	29.0	29.0	28.3	29.0									
					M_{max}	16.4	20.0	29.0	29.0	28.3	29.0									
					η_{eto}	-	-	-	-	-	-									
12H34-	10.5	3375	7.5	3.70	M_0				10.2	12.8	12.8									
					M_N				10.0	10.5	10.5									
					$M_{0,max}$				18.8	23.5	24.1									
					M_{max}				18.8	23.5	24.1									
					η_{eto}				-	-	-									
12L17-	17.0	1650	6.7	2.90	M_0				18.5	19.0	19.0									
					M_N				17.0	17.0	17.0									
					$M_{0,max}$				33.9	40.8	41.9									
					M_{max}				33.9	40.8	41.9									
					η_{eto}				-	-	-									
12L39-	14.0	3900	11.7	5.70	M_0					17.2	17.2	19.0	19.0	19.0						
					M_N					14.0	14.0	14.0	14.0	14.0						
					$M_{0,max}$					22.2	30.4	35.5	35.5	35.5						
					M_{max}					22.2	30.4	49.6	49.6	49.6						
					η_{eto}					-	-	-	-	-						
14D14-	12.0	1350	5.4	1.70	M_0		8.5	12.5	12.5	12.5	12.5									
					M_N		8.0	12.0	12.0	12.0	12.0									
					$M_{0,max}$		16.0	22.7	28.1	28.3	29.0									
					M_{max}		16.0	22.7	28.1	28.3	29.0									
					η_{eto}		-	-	-	-	-									
14D30-	10.5	3000	9.7	3.30	M_0				7.7	12.2	12.5	12.5	12.5							
					M_N				7.0	9.8	10.0	10.0	10.0							
					$M_{0,max}$				15.2	18.5	25.3	29.0	29.0							
					M_{max}				15.2	18.5	22.2	22.2	22.2							
					η_{eto}				-	-	-	-	-							
14H12-	23.5	1200	8.3	3.00	M_0				18.0	25.5	25.5									
					M_N				17.9	23.5	23.5									
					$M_{0,max}$				35.3	42.8	43.9									
					M_{max}				35.3	42.8	43.9									
					η_{eto}				-	-	-									

- $I...$ [A], $M...$ [Nm], $n...$ [r/min], $P...$ [kW]

MCS synchronous servo motors

Technical data



Selection tables, Inverter Drives 8400 TopLine

Forced ventilated IP54 motors

- The data applies to a mains connection voltage of 3 x 400 V and an inverter switching frequency of 8 kHz.

					E84AVTC	□1124	□1524	□2224	□3024	□4024	□5524	□7524	□1134	□1534	□1834	□2234	□3034					
					I_N	3.2	3.9	5.9	7.3	9.5	13.0	16.5	23.5	32.0	39.0	47.0	61.0					
					$I_{0,max}$	4.8	5.9	8.4	11.0	14.3	19.5	26.4	32.9	43.2	60.0	70.5	91.5					
MCS	M_N	n_N	I_N	P_N	I_{max}	6.4	7.8	11.8	14.6	19.0	26.0	33.0	47.0	64.0	78.0	94.0	122.0					
14H28-	20.5	2775	15.0	6.00	M_0						16.2	25.5	25.5	25.5								
					M_N					16.1	20.5	20.5	20.5									
					$M_{0,max}$								31.7	37.1	37.1	37.1						
					M_{max}									31.7	51.9	51.9	51.9					
					η_{eto}									-	-	-	-					
14L14-	30.5	1350	11.8	4.30	M_0					26.9	33.4	34.5	34.5									
					M_N					24.6	30.5	30.5	30.5									
					$M_{0,max}$								43.8	52.9	52.9	52.9						
					M_{max}									43.8	60.0	73.8	73.8					
					η_{eto}									-	-	-	-					
14L30-	25.5	3000	20.8	8.00	M_0								27.4	34.5	34.5	34.5						
					M_N								25.5	25.5	25.5	25.5						
					$M_{0,max}$									52.9	52.9	52.9	52.9					
					M_{max}										73.9	73.9	73.9	73.9				
					η_{eto}										-	-	-	-				
14P11-	42.0	1050	13.4	4.60	M_0						38.9	43.5	43.5	43.5								
					M_N						38.8	42.0	42.0	42.0								
					$M_{0,max}$								70.0	80.0	80.0	80.0						
					M_{max}									70.0	105.1	105.1	105.1					
					η_{eto}										-	-	-	-				
14P26-	33.0	2625	21.9	9.10	M_0								35.8	43.5	43.5	43.5						
					M_N									33.0	33.0	33.0	33.0					
					$M_{0,max}$										66.0	86.4	86.4	86.4				
					M_{max}											86.4	86.4	86.4	86.4			
					η_{eto}											-	-	-	-			
19F12-	38.0	1200	11.3	4.80	M_0			23.6	34.9	41.5	41.5	41.5										
					M_N				22.9	31.9	38.0	38.0	38.0									
					$M_{0,max}$					45.9	56.7	68.3	68.3	68.3								
					M_{max}						45.9	56.7	77.6	86.0	86.0							
					η_{eto}							-	-	-	-	-						
19F29-	32.5	2850	20.1	9.70	M_0								39.9	41.5								
					M_N									32.5	32.5							
					$M_{0,max}$										47.2	47.2						
					M_{max}											68.3	68.3					
					η_{eto}											-	-					
19J12-	62.5	1200	18.3	7.90	M_0						43.6		70.5	70.5								
					M_N							43.4		62.5	62.5							
					$M_{0,max}$								81.1	96.0	96.0							
					M_{max}									81.1	129.0	129.0						
					η_{eto}										-	-						
19J29-	50.5	2850	31.0	15.10	M_0									55.5	70.5	70.5	70.5					
					M_N										50.5	50.5	50.5	50.5				
					$M_{0,max}$											87.6	87.6	87.6	87.6			
					M_{max}												127.6	127.6	127.6	127.6		
					η_{eto}												-	-	-	-		

- $I...$ [A], $M...$ [Nm], $n...$ [r/min], $P...$ [kW]

MCS synchronous servo motors

Technical data



Selection tables, Inverter Drives 8400 TopLine

Forced ventilated IP54 motors

- The data applies to a mains connection voltage of 3 x 400 V and an inverter switching frequency of 8 kHz.

					E84AVTC	□1124	□1524	□2224	□3024	□4024	□5524	□7524	□1134	□1534	□1834	□2234	□3034
					I_N	3.2	3.9	5.9	7.3	9.5	13.0	16.5	23.5	32.0	39.0	47.0	61.0
					$I_{0,max}$	4.8	5.9	8.4	11.0	14.3	19.5	26.4	32.9	43.2	60.0	70.5	91.5
MCS	M_N	n_N	I_N	P_N	I_{max}	6.4	7.8	11.8	14.6	19.0	26.0	33.0	47.0	64.0	78.0	94.0	122.0
19P12-	72.0	1200	21.3	9.00	M_0						47.5		86.0	86.0			
					M_N					46.4	72.0	72.0					
					$M_{0,max}$					92.7	106.7	106.7					
					M_{max}					92.7	155.5	155.5					
					η_{eto}									-	-	-	
19P29-	53.0	2850	29.5	15.80	M_0									58.7	86.0	86.0	86.0
					M_N									53.0	53.0	53.0	53.0
					$M_{0,max}$									87.6	87.6	87.6	87.6
					M_{max}									144.3	144.3	144.3	144.3
					η_{eto}												

- I... [A], M... [Nm], n... [r/min], P... [kW]

MCS synchronous servo motors

Technical data



Selection tables, Servo Drives ECS

Non-ventilated motors

- The data applies to a mains connection voltage of 3 x 400 V and an inverter switching frequency of 4 kHz.

					ECS□□	004C□B	008C□B	016C□B	032C□B	048C□B	064C□B
					I_N	2.0	4.0	8.0	12.7	17.0	20.0
					$I_{0,max}$	2.3	4.6	9.1	18.1	27.2	36.3
MCS	M_N	n_N	I_N	P_N	I_{max}	4.0	8.0	16.0	32.0	48.0	64.0
06C41-	0.6	4050	1.3	0.25	M_0	0.8					
					M_N	0.6					
					$M_{0,max}$	1.2					
					M_{max}	1.9					
					n_{eto}	2747					
06C60-	0.5	6000	2.4	0.31	M_0	0.6	0.8				
					M_N	0.4	0.5				
					$M_{0,max}$	0.6	1.2				
					M_{max}	1.0	1.9				
					n_{eto}	7000	6814				
06F41-	1.2	4050	1.5	0.51	M_0	1.5					
					M_N	1.2					
					$M_{0,max}$	2.0					
					M_{max}	3.6					
					n_{eto}	1902					
06F60-	0.9	6000	2.5	0.57	M_0	1.0	1.5				
					M_N	0.7	0.9				
					$M_{0,max}$	1.0	2.0				
					M_{max}	1.8	3.7				
					n_{eto}	7000	4602				
06I41-	1.5	4050	1.6	0.64	M_0	2.0	2.0				
					M_N	1.5	1.5				
					$M_{0,max}$	2.6	5.0				
					M_{max}	4.4	6.2				
					n_{eto}	1898	1384				
06I60-	1.2	6000	2.9	0.75	M_0	1.2	2.0	2.0			
					M_N	0.8	1.2	1.2			
					$M_{0,max}$	1.3	2.6	5.2			
					M_{max}	2.2	4.7	6.2			
					n_{eto}	6407	4200	3157			
09D41-	2.3	4050	2.3	1.00	M_0		3.3	3.3			
					M_N		2.3	2.3			
					$M_{0,max}$		5.0	8.8			
					M_{max}		8.0	9.4			
					n_{eto}		2361	2008			
09D60-	1.8	6000	3.8	1.10	M_0		2.5	3.3			
					M_N		1.8	1.8			
					$M_{0,max}$		2.5	4.9			
					M_{max}		4.4	8.0			
					n_{eto}		7000	5217			
09F38-	3.1	3750	2.5	1.20	M_0		4.2	4.2			
					M_N		3.1	3.1			
					$M_{0,max}$		6.2	10.8			
					M_{max}		9.8	14.9			
					n_{eto}		2589	1737			

- I... [A], M... [Nm], n... [r/min], P... [kW]

MCS synchronous servo motors

Technical data



Selection tables, Servo Drives ECS

Non-ventilated motors

- The data applies to a mains connection voltage of 3 x 400 V and an inverter switching frequency of 4 kHz.

					ECS□□	004C□B	008C□B	016C□B	032C□B	048C□B	064C□B
					I_N	2.0	4.0	8.0	12.7	17.0	20.0
					$I_{0,max}$	2.3	4.6	9.1	18.1	27.2	36.3
MCS	M_N	n_N	I_N	P_N	I_{max}	4.0	8.0	16.0	32.0	48.0	64.0
09F60-	2.4	6000	4.5	1.50	M_0		2.8	4.2	4.2		
					M_N		2.1	2.4	2.4		
					$M_{0,max}$		3.2	6.1	10.8		
					M_{max}		5.4	9.8	14.9		
					n_{eto}		7000	5906	3715		
09H41-	3.8	4050	3.4	1.60	M_0		5.2	5.5			
					M_N		3.8	3.8			
					$M_{0,max}$		5.9	11.1			
					M_{max}		9.9	17.5			
					n_{eto}		3675	2231			
09H60-	3.0	6000	6.0	1.90	M_0			5.2	5.5	5.5	
					M_N			3.0	3.0	3.0	
					$M_{0,max}$			5.9	11.0	15.5	
					M_{max}			9.9	17.5	20.4	
					n_{eto}			7000	5061	4375	
09L41-	4.5	4050	4.2	1.90	M_0		4.8	7.5	7.5		
					M_N		4.3	4.5	4.5		
					$M_{0,max}$		5.2	10.3	19.5		
					M_{max}		9.1	17.4	31.9		
					n_{eto}		4450	3188	1878		
09L51-	3.6	5100	6.9	1.90	M_0			4.8	7.5	7.5	7.5
					M_N			3.6	3.6	3.6	3.6
					$M_{0,max}$			5.2	10.3	15.1	19.6
					M_{max}			9.1	17.5	25.1	31.9
					n_{eto}			7000	7000	5647	4076
12D20-	5.5	1950	2.6	1.10	M_0	4.7	6.4	6.4			
					M_N	4.2	5.5	5.5			
					$M_{0,max}$	4.6	9.1	17.0			
					M_{max}	8.0	15.3	17.7			
					n_{eto}	1730	1089	919			
12D41-	4.3	4050	4.5	1.80	M_0		4.7	6.4			
					M_N		3.8	4.3			
					$M_{0,max}$		4.6	8.8			
					M_{max}		7.8	14.7			
					n_{eto}		3902	2433			
12H15-	10.0	1500	3.8	1.60	M_0		11.2	11.4			
					M_N		10.0	10.0			
					$M_{0,max}$		11.9	22.6			
					M_{max}		20.1	29.0			
					n_{eto}		1220	918			
12H35-	7.5	3525	5.7	2.80	M_0		5.6	11.2	11.4		
					M_N		5.3	7.5	7.5		
					$M_{0,max}$		6.0	11.8	22.5		
					M_{max}		10.4	20.1	29.0		
					n_{eto}		3850	2838	2092		

- $I...$ [A], $M...$ [Nm], $n...$ [r/min], $P...$ [kW]

6.11

MCS synchronous servo motors

Technical data



Selection tables, Servo Drives ECS

Non-ventilated motors

- The data applies to a mains connection voltage of 3 x 400 V and an inverter switching frequency of 4 kHz.

					ECS□□	004C□B	008C□B	016C□B	032C□B	048C□B	064C□B
					I_N	2.0	4.0	8.0	12.7	17.0	20.0
					$I_{0,max}$	2.3	4.6	9.1	18.1	27.2	36.3
MCS	M_N	n_N	I_N	P_N	I_{max}	4.0	8.0	16.0	32.0	48.0	64.0
12L20-	13.5	1950	5.9	2.80	M_0			15.0	15.0		
					M_N			13.5	13.5		
					$M_{0,max}$			21.4	39.4		
					M_{max}			35.5	56.4		
					n_{eto}			1324	863		
12L41-	11.0	4050	10.2	4.70	M_0			9.7	15.0	15.0	15.0
					M_N			8.6	11.0	11.0	11.0
					$M_{0,max}$			10.8	21.3	30.8	39.5
					M_{max}			19.0	35.5	49.6	56.4
					n_{eto}			4450	3013	2236	1907
14D15-	9.2	1500	4.5	1.45	M_0		8.8	11.0			
					M_N		8.2	9.2			
					$M_{0,max}$		9.6	17.9			
					M_{max}		15.9	28.3			
					n_{eto}		1141	689			
14D36-	7.5	3600	7.5	2.80	M_0			8.8	11.0		
					M_N			7.5	7.5		
					$M_{0,max}$			9.5	17.8		
					M_{max}			15.9	28.3		
					n_{eto}			2496	1614		
14H15-	16.0	1500	6.6	2.50	M_0			19.8	21.0		
					M_N			16.0	16.0		
					$M_{0,max}$			22.3	41.2		
					M_{max}			37.1	54.8		
					n_{eto}			920	667		
14H32-	14.0	3225	11.9	4.70	M_0				15.8	21.0	21.0
					M_N				14.0	14.0	14.0
					$M_{0,max}$				22.2	32.1	41.3
					M_{max}				37.1	51.9	54.8
					n_{eto}				1953	1471	1409
14L15-	23.0	1500	9.7	3.60	M_0			18.7	28.0	28.0	
					M_N			19.0	23.0	23.0	
					$M_{0,max}$			21.9	42.1	59.9	
					M_{max}			37.6	68.5	77.1	
					n_{eto}			1284	828	767	
14L32-	17.2	3225	15.0	5.80	M_0				14.8	19.8	23.3
					M_N				14.6	17.2	17.2
					$M_{0,max}$				21.8	32.4	42.2
					M_{max}				37.6	53.9	68.5
					n_{eto}				2801	2096	1757
14P14-	30.0	1350	10.8	4.20	M_0				37.0	37.0	37.0
					M_N				30.0	30.0	30.0
					$M_{0,max}$				49.1	70.0	88.4
					M_{max}				80.0	105.1	105.1
					n_{eto}				710	573	573

- $I...$ [A], $M...$ [Nm], $n...$ [r/min], $P...$ [kW]

MCS synchronous servo motors

Technical data



Selection tables, Servo Drives ECS

Non-ventilated motors

- The data applies to a mains connection voltage of 3 x 400 V and an inverter switching frequency of 4 kHz.

					ECS□□	004C□B	008C□B	016C□B	032C□B	048C□B	064C□B
					I_N	2.0	4.0	8.0	12.7	17.0	20.0
					$I_{0,max}$	2.3	4.6	9.1	18.1	27.2	36.3
MCS	M_N	n_N	I_N	P_N	I_{max}	4.0	8.0	16.0	32.0	48.0	64.0
14P32-	21.0	3225	15.6	7.10	M_0				19.3	25.9	30.5
					M_N				17.1	21.0	21.0
					$M_{0,max}$				25.4	37.9	49.3
					M_{max}				43.9	63.0	80.0
					n_{eto}				2469	1829	1495
19F14-	27.0	1425	8.6	4.00	M_0			25.9	32.0		
					M_N			25.1	27.0		
					$M_{0,max}$			28.6	54.6		
					M_{max}			48.9	86.0		
					n_{eto}			1204	746		
19F30-	21.0	3000	14.0	6.60	M_0				20.5	27.5	32.0
					M_N				19.0	21.0	21.0
					$M_{0,max}$				27.2	40.5	53.0
					M_{max}				47.2	68.3	86.0
					n_{eto}				2774	2033	1653
19J14-	40.0	1425	12.3	6.00	M_0				42.6	51.0	
					M_N				40.0	40.0	
					$M_{0,max}$				58.9	82.8	
					M_{max}				96.0	129.0	
					n_{eto}				1063	839	
19J30-	29.0	3000	18.5	9.10	M_0					28.4	33.4
					M_N					26.6	29.0
					$M_{0,max}$					42.6	56.9
					M_{max}					73.8	96.0
					n_{eto}					2850	2323
19P14-	51.0	1350	14.3	7.20	M_0				46.4	62.2	64.0
					M_N				45.3	51.0	51.0
					$M_{0,max}$				64.6	91.5	120.1
					M_{max}				106.7	155.5	190.0
					n_{eto}				1227	996	870
19P30-	32.0	3000	19.0	10.00	M_0					31.2	36.7
					M_N					28.6	32.0
					$M_{0,max}$					45.8	61.1
					M_{max}					81.2	106.7
					n_{eto}					2938	2715

- I... [A], M... [Nm], n... [r/min], P... [kW]

MCS synchronous servo motors

Technical data



Selection tables, Servo Drives ECS

Non-ventilated motors

- The data applies to a mains connection voltage of 3x230V and an inverter switching frequency of 4 kHz.

					ECS□□	004C□B	008C□B	016C□B	032C□B	048C□B	064C□B
					I_N	2.0	4.0	8.0	12.7	17.0	20.0
					$I_{0,max}$	2.3	4.6	9.1	18.1	27.2	36.3
MCS	M_N	n_N	I_N	P_N	I_{max}	4.0	8.0	16.0	32.0	48.0	64.0
06C41L	0.6	4050	2.6	0.25	M_0	0.6	0.8				
					M_N	0.5	0.6				
					$M_{0,max}$	0.6	1.1				
					M_{max}	1.0	1.9				
					n_{eto}	6298	2835				
06C60L	0.5	6000	4.0	0.31	M_0		0.7	0.8			
					M_N		0.5	0.5			
					$M_{0,max}$		0.7	1.3			
					M_{max}		1.2	2.2			
					n_{eto}		7000	1149			
06F41L	1.2	4050	2.9	0.51	M_0	1.0	1.5	1.5			
					M_N	0.8	1.2	1.2			
					$M_{0,max}$	1.2	2.1	3.9			
					M_{max}	1.9	3.5	4.4			
					n_{eto}	3838	2118	2831			
06F60L	0.9	6000	3.8	0.57	M_0		1.5	1.5			
					M_N		0.9	0.9			
					$M_{0,max}$		1.5	2.9			
					M_{max}		2.6	4.3			
					n_{eto}		6138	3182			
06I41L	1.5	4050	3.2	0.64	M_0	1.3	2.0	2.0			
					M_N	1.0	1.5	1.5			
					$M_{0,max}$	1.4	2.8	5.0			
					M_{max}	2.4	4.4	6.2			
					n_{eto}	3549	1947	2831			
06I60L	1.2	6000	3.8	0.75	M_0		1.9	2.0			
					M_N		1.2	1.2			
					$M_{0,max}$		2.1	4.1			
					M_{max}		3.6	6.2			
					n_{eto}		3417	1149			
09D41L	2.3	4050	4.6	1.00	M_0		2.5	3.3	3.3		
					M_N		2.0	2.3	2.3		
					$M_{0,max}$		2.5	4.9	8.8		
					M_{max}		4.4	8.0	9.5		
					n_{eto}		4091	2547	2170		
09D60L	1.8	6000	7.0	1.10	M_0			2.6	3.3	3.3	
					M_N			1.8	1.8	1.8	
					$M_{0,max}$			2.6	5.0	7.1	
					M_{max}			4.5	8.1	9.5	
					n_{eto}			7000	5373	4626	
09F38L	3.1	3750	5.0	1.20	M_0			4.2	4.2		
					M_N			3.1	3.1		
					$M_{0,max}$			6.1	10.8		
					M_{max}			9.8	15.0		
					n_{eto}			1149	1951		

- $I...$ [A], $M...$ [Nm], $n...$ [r/min], $P...$ [kW]

MCS synchronous servo motors

Technical data



Selection tables, Servo Drives ECS

Non-ventilated motors

- The data applies to a mains connection voltage of 3x230V and an inverter switching frequency of 4 kHz.

					ECS□□	004C□B	008C□B	016C□B	032C□B	048C□B	064C□B
					I_N	2.0	4.0	8.0	12.7	17.0	20.0
					$I_{0,max}$	2.3	4.6	9.1	18.1	27.2	36.3
MCS	M_N	n_N	I_N	P_N	I_{max}	4.0	8.0	16.0	32.0	48.0	64.0
09F60L	2.4	6000	7.9	1.50	M_0			3.2	4.2	4.2	4.2
					M_N			2.4	2.4	2.4	2.4
					$M_{0,max}$			3.6	6.8	9.6	11.9
					M_{max}			6.1	10.9	14.3	15.0
					η_{eto}			6985	3448	2612	2397
09H41L	3.8	4050	6.8	1.60	M_0			5.2	5.5	5.5	
					M_N			3.8	3.8	3.8	
					$M_{0,max}$			5.9	11.0	15.3	
					M_{max}			9.9	17.2	20.0	
					η_{eto}			1149	2138	1852	
09H60L	3.0	6000	8.0	1.90	M_0			3.7	5.5	5.5	5.5
					M_N			3.0	3.0	3.0	3.0
					$M_{0,max}$			4.1	8.0	11.5	14.5
					M_{max}			7.2	13.2	17.9	20.0
					η_{eto}			1149	4081	2984	2695
09L41L	4.5	4050	8.4	1.90	M_0			4.8	7.5	7.5	7.5
					M_N			4.3	4.5	4.5	4.5
					$M_{0,max}$			5.2	10.3	15.1	19.6
					M_{max}			9.1	17.5	25.1	31.9
					η_{eto}			4562	3243	2497	1909
12D20L	5.5	1950	5.2	1.10	M_0		4.7	6.4			
					M_N		4.2	5.5			
					$M_{0,max}$		4.6	9.0			
					M_{max}		8.0	14.9			
					η_{eto}		1878	1181			
12D41L	4.3	4050	8.8	1.80	M_0			4.8	6.4	6.4	
					M_N			3.9	4.3	4.3	
					$M_{0,max}$			4.6	9.2	13.3	
					M_{max}			8.1	15.2	17.9	
					η_{eto}			4102	2535	2187	
12H15L	10.0	1500	7.6	1.60	M_0			11.2	11.4		
					M_N			10.0	10.0		
					$M_{0,max}$			11.8	22.5		
					M_{max}			20.1	29.0		
					η_{eto}			1098	827		
12H30L	8.0	3000	10.5	2.50	M_0			6.8	10.7	11.4	
					M_N			6.1	8.0	8.0	
					$M_{0,max}$			7.2	14.3	20.9	
					M_{max}			12.7	24.3	29.0	
					η_{eto}			2831	1849	1591	
12L20L	13.5	1950	11.8	2.80	M_0				15.0	15.0	15.0
					M_N				13.5	13.5	13.5
					$M_{0,max}$				21.3	30.7	39.4
					M_{max}				35.4	49.3	56.0
					η_{eto}				1307	1004	866

- $I...$ [A], $M...$ [Nm], $n...$ [r/min], $P...$ [kW]

MCS synchronous servo motors

Technical data



Selection tables, Servo Drives ECS

Forced ventilated IP54 motors

- The data applies to a mains connection voltage of 3 x 400 V and an inverter switching frequency of 4 kHz.

					ECS□□	004C□B	008C□B	016C□B	032C□B	048C□B	064C□B
					I_N	2.0	4.0	8.0	12.7	17.0	20.0
					$I_{0,max}$	2.3	4.6	9.1	18.1	27.2	36.3
MCS	M_N	n_N	I_N	P_N	I_{max}	4.0	8.0	16.0	32.0	48.0	64.0
12D17-	7.0	1650	3.0	1.20	M_0	4.7	7.5	7.5			
					M_N	4.2	7.0	7.0			
					$M_{0,max}$	4.6	9.1	17.0			
					M_{max}	8.0	15.3	17.7			
					n_{eto}	1730	1089	919			
12D35-	6.0	3525	5.6	2.20	M_0		4.7	7.5			
					M_N		3.8	6.0			
					$M_{0,max}$		4.6	8.8			
					M_{max}		7.8	14.7			
					n_{eto}		3902	2433			
12H14-	12.0	1350	4.1	1.70	M_0		11.2	12.8			
					M_N		10.6	12.0			
					$M_{0,max}$		11.9	22.6			
					M_{max}		20.1	29.0			
					n_{eto}		1220	918			
12H34-	10.5	3375	7.5	3.70	M_0		5.6	11.2	12.8		
					M_N		5.3	10.0	7.5		
					$M_{0,max}$		6.0	11.8	22.5		
					M_{max}		10.4	20.1	29.0		
					n_{eto}		3850	2838	2092		
12L17-	17.0	1650	6.7	2.90	M_0			19.0	19.0		
					M_N			17.0	17.0		
					$M_{0,max}$			21.4	39.4		
					M_{max}			35.5	56.4		
					n_{eto}			1324	863		
12L39-	14.0	3900	11.7	5.70	M_0			9.7	16.7	19.0	19.0
					M_N			8.6	14.0	14.0	14.0
					$M_{0,max}$			10.8	21.3	30.8	39.5
					M_{max}			19.0	35.5	49.6	56.4
					n_{eto}			4450	3013	2236	1907
14D14-	12.0	1350	5.4	1.70	M_0		8.8	12.5			
					M_N		8.2	12.0			
					$M_{0,max}$		9.6	17.9			
					M_{max}		15.9	28.3			
					n_{eto}		1141	689			
14D30-	10.5	3000	9.7	3.30	M_0			8.8	11.4		
					M_N			8.6	9.7		
					$M_{0,max}$			9.5	17.8		
					M_{max}			15.9	28.3		
					n_{eto}			2496	1614		
14H12-	23.5	1200	8.3	3.00	M_0			19.8	25.5		
					M_N			19.6	23.5		
					$M_{0,max}$			22.3	41.2		
					M_{max}			37.1	54.8		
					n_{eto}			920	667		

- $I...$ [A], $M...$ [Nm], $n...$ [r/min], $P...$ [kW]

MCS synchronous servo motors

Technical data



Selection tables, Servo Drives ECS

Forced ventilated IP54 motors

- The data applies to a mains connection voltage of 3 x 400 V and an inverter switching frequency of 4 kHz.

					ECS□□	004C□B	008C□B	016C□B	032C□B	048C□B	064C□B
					I_N	2.0	4.0	8.0	12.7	17.0	20.0
					$I_{0,max}$	2.3	4.6	9.1	18.1	27.2	36.3
MCS	M_N	n_N	I_N	P_N	I_{max}	4.0	8.0	16.0	32.0	48.0	64.0
14H28-	20.5	2775	15.0	6.00	M_0				15.8	23.5	25.5
					M_N				15.6	20.5	20.5
					$M_{0,max}$				22.2	32.1	41.3
					M_{max}				37.1	51.9	54.8
					η_{eto}					1953	1471
14L14-	30.5	1350	11.8	4.30	M_0			18.7	32.7	34.5	
					M_N			19.0	30.5	30.5	
					$M_{0,max}$			21.9	42.1	59.9	
					M_{max}			37.6	68.5	77.1	
					η_{eto}			1284	828	767	
14L30-	25.5	3000	20.8	8.00	M_0					19.8	23.3
					M_N					19.7	23.3
					$M_{0,max}$					32.4	42.2
					M_{max}					53.9	68.5
					η_{eto}					2096	1757
14P11-	42.0	1050	13.4	4.60	M_0				39.1	43.5	43.5
					M_N				38.9	42.0	42.0
					$M_{0,max}$				49.1	70.0	88.4
					M_{max}				80.0	105.1	105.1
					η_{eto}				710	573	573
14P26-	33.0	2625	21.9	9.10	M_0					25.9	30.5
					M_N					25.6	30.1
					$M_{0,max}$					37.9	49.3
					M_{max}					63.0	80.0
					η_{eto}					1829	1495
19F12-	38.0	1200	11.3	4.80	M_0			25.9	41.5		
					M_N			25.1	38.0		
					$M_{0,max}$			28.6	54.6		
					M_{max}			48.9	86.0		
					η_{eto}			1204	746		
19F29-	32.5	2850	20.1	9.70	M_0					27.5	33.9
					M_N					27.4	32.5
					$M_{0,max}$					40.5	53.0
					M_{max}					68.3	86.0
					η_{eto}					2033	1653
19J12-	62.5	1200	18.3	7.90	M_0					59.0	69.4
					M_N					58.1	62.5
					$M_{0,max}$					82.8	82.8
					M_{max}					129.0	129.0
					η_{eto}					839	839
19J29-	50.5	2850	31.0	15.10	M_0						34.3
					M_N						32.6
					$M_{0,max}$						56.9
					M_{max}						96.0
					η_{eto}						2323

- $I...$ [A], $M...$ [Nm], $n...$ [r/min], $P...$ [kW]

MCS synchronous servo motors

Technical data



Selection tables, Servo Drives ECS

Forced ventilated IP54 motors

- The data applies to a mains connection voltage of 3 x 400 V and an inverter switching frequency of 4 kHz.

					ECS□□	004C□B	008C□B	016C□B	032C□B	048C□B	064C□B
					I_N	2.0	4.0	8.0	12.7	17.0	20.0
					$I_{0,max}$	2.3	4.6	9.1	18.1	27.2	36.3
MCS	M_N	n_N	I_N	P_N	I_{max}	4.0	8.0	16.0	32.0	48.0	64.0
19P12-	72.0	1200	21.3	9.00	M_0					62.2	76.8
					M_N					57.5	67.6
					$M_{0,max}$					91.5	120.1
					M_{max}					155.5	190.0
					η_{eto}					996	870
19P29-	53.0	2850	29.5	15.80	M_0						36.7
					M_N						35.9
					$M_{0,max}$						61.1
					M_{max}						106.7
					η_{eto}						2715

- I... [A], M... [Nm], n... [r/min], P... [kW]

MCS synchronous servo motors

Technical data



Selection tables, Servo Inverter 9300

Non-ventilated motors

- The data applies to a mains connection voltage of 3 x 400 V and an inverter switching frequency of 8 kHz.

					EVS	9321- E□	9322- E□	9323- E□	9324- E□	9325- E□	9326- E□	9327- E□	9328- E□	9329- E□
					I _N	1.5	2.5	3.9	7.0	13.0	23.5	32.0	47.0	59.0
					I _{0,max}	2.3	3.8	5.9	10.5	19.5	23.5	32.0	47.0	52.0
MCS	M _N	n _N	I _N	P _N	I _{max}	2.3	3.8	5.9	10.5	19.5	35.3	48.0	70.5	88.5
06C41-	0.6	4050	1.3	0.25	M ₀	0.8	0.8	0.8						
					M _N	0.6	0.6	0.6						
					M _{0,max}	1.2	1.8	2.4						
					M _{max}	1.2	1.8	2.4						
					n _{eto}	4635	2871	2019						
06C60-	0.5	6000	2.4	0.31	M ₀		0.8	0.8	0.8					
					M _N		0.5	0.5	0.5					
					M _{0,max}		1.0	1.5	2.4					
					M _{max}		1.0	1.5	2.4					
					n _{eto}		7000	7000	5368					
06F41-	1.2	4050	1.5	0.51	M ₀	1.5	1.5	1.5						
					M _N	1.2	1.2	1.2						
					M _{0,max}	2.0	3.4	4.4						
					M _{max}	2.0	3.4	4.4						
					n _{eto}	2819	1973	1562						
06F60-	0.9	6000	2.5	0.57	M ₀		1.3	1.5	1.5					
					M _N		0.9	0.9	0.9					
					M _{0,max}		1.7	3.0	4.4					
					M _{max}		1.7	3.0	4.4					
					n _{eto}		7000	5714	3773					
06I41-	1.5	4050	1.6	0.64	M ₀	1.8	2.0	2.0						
					M _N	1.4	1.5	1.5						
					M _{0,max}	2.6	4.2	6.2						
					M _{max}	2.6	4.2	6.2						
					n _{eto}	2994	1980	1384						
06I60-	1.2	6000	2.9	0.75	M ₀		1.5	2.0	2.0					
					M _N		1.0	1.2	1.2					
					M _{0,max}		2.1	3.3	5.7					
					M _{max}		2.1	3.3	5.7					
					n _{eto}		7000	5486	3414					
09D41-	2.3	4050	2.3	1.00	M ₀		3.1	3.3	3.3					
					M _N		2.3	2.3	2.3					
					M _{0,max}		4.2	6.2	9.4					
					M _{max}		4.2	6.2	9.4					
					n _{eto}		4895	2937	2008					
09D60-	1.8	6000	3.8	1.10	M ₀			2.4	3.3	3.3				
					M _N			1.8	1.8	1.8				
					M _{0,max}			3.2	5.6	9.3				
					M _{max}			3.2	5.6	9.3				
					n _{eto}			7000	7000	4492				
09F38-	3.1	3750	2.5	1.20	M ₀		3.5	4.2	4.2					
					M _N		3.1	3.1	3.1					
					M _{0,max}		5.2	7.7	12.0					
					M _{max}		5.2	7.7	12.0					
					n _{eto}		4000	3250	2173					

- I... [A], M... [Nm], n... [r/min], P... [kW]

6.11

MCS synchronous servo motors

Technical data



Selection tables, Servo Inverter 9300

Non-ventilated motors

- The data applies to a mains connection voltage of 3 x 400 V and an inverter switching frequency of 8 kHz.

					EVS	9321- E□	9322- E□	9323- E□	9324- E□	9325- E□	9326- E□	9327- E□	9328- E□	9329- E□	
					I _N	1.5	2.5	3.9	7.0	13.0	23.5	32.0	47.0	59.0	
					I _{0,max}	2.3	3.8	5.9	10.5	19.5	23.5	32.0	47.0	52.0	
MCS	M _N	n _N	I _N	P _N	I _{max}	2.3	3.8	5.9	10.5	19.5	35.3	48.0	70.5	88.5	
09F60-	2.4	6000	4.5	1.50	M ₀				4.2	4.2					
					M _N				2.4	2.4					
					M _{0,max}				6.9	11.4					
					M _{max}				6.9	11.4					
					n _{eto}				7000	5035					
09H41-	3.8	4050	3.4	1.60	M ₀			5.0	5.5	5.5					
					M _N			3.8	3.8	3.8					
					M _{0,max}			7.5	12.5	20.1					
					M _{max}			7.5	12.5	20.1					
					n _{eto}			4250	2977	1988					
09H60-	3.0	6000	6.0	1.90	M ₀				4.5	5.5					
					M _N				3.0	3.0					
					M _{0,max}				6.7	11.7					
					M _{max}				6.7	11.7					
					n _{eto}				7000	7000					
09L41-	4.5	4050	4.2	1.90	M ₀			4.7	7.5	7.5					
					M _N			4.2	4.5	4.5					
					M _{0,max}			6.7	11.7	20.8					
					M _{max}			6.7	11.7	20.8					
					n _{eto}			4450	4154	2796					
09L51-	3.6	5100	6.9	1.90	M ₀				4.2	7.5	7.5				
					M _N				3.6	3.6	3.6				
					M _{0,max}				6.0	11.1	13.2				
					M _{max}				6.0	11.1	19.1				
					n _{eto}				7000	7000	7000				
12D20-	5.5	1950	2.6	1.10	M ₀		5.9	6.4	6.4						
					M _N		5.3	5.5	5.5						
					M _{0,max}		7.6	11.6	17.7						
					M _{max}		7.6	11.6	17.7						
					n _{eto}		1790	1358	919						
12D41-	4.3	4050	4.5	1.80	M ₀			4.6	6.4	6.4					
					M _N			3.7	4.3	4.3					
					M _{0,max}			5.9	10.1	17.3					
					M _{max}			5.9	10.1	17.3					
					n _{eto}			4344	3275	2116					
12H15-	10.0	1500	3.8	1.60	M ₀			10.9	11.4	11.4					
					M _N			10.0	10.0	10.0					
					M _{0,max}			15.1	25.8	29.0					
					M _{max}			15.1	25.8	29.0					
					n _{eto}			1676	1013	918					
12H35-	7.5	3525	5.7	2.80	M ₀				9.8	11.4					
					M _N				7.5	7.5					
					M _{0,max}				13.5	24.1					
					M _{max}				13.5	24.1					
					n _{eto}				3618	2447					

- I... [A], M... [Nm], n... [r/min], P... [kW]

MCS synchronous servo motors

Technical data



Selection tables, Servo Inverter 9300

Non-ventilated motors

- The data applies to a mains connection voltage of 3 x 400 V and an inverter switching frequency of 8 kHz.

					EVS	9321- E□	9322- E□	9323- E□	9324- E□	9325- E□	9326- E□	9327- E□	9328- E□	9329- E□
					I _N	1.5	2.5	3.9	7.0	13.0	23.5	32.0	47.0	59.0
					I _{0,max}	2.3	3.8	5.9	10.5	19.5	23.5	32.0	47.0	52.0
MCS	M _N	n _N	I _N	P _N	I _{max}	2.3	3.8	5.9	10.5	19.5	35.3	48.0	70.5	88.5
12L20-	13.5	1950	5.9	2.80	M ₀				15.0	15.0				
					M _N				13.5	13.5				
					M _{0,max}				24.4	41.9				
					M _{max}				24.4	41.9				
					n _{eto}				1718	1158				
12L41-	11.0	4050	10.2	4.70	M ₀					15.0	15.0	15.0		
					M _N					11.0	11.0	11.0		
					M _{0,max}					22.8	27.0	35.5		
					M _{max}					22.8	38.5	49.6		
					n _{eto}					4287	2799	2236		
14D15-	9.2	1500	4.5	1.45	M ₀			8.5	11.0	11.0				
					M _N			8.0	9.2	9.2				
					M _{0,max}			12.1	20.2	29.0				
					M _{max}			12.1	20.2	29.0				
					n _{eto}			1437	928	676				
14D36-	7.5	3600	7.5	2.80	M ₀				7.7	11.0	11.0			
					M _N				7.0	7.5	7.5			
					M _{0,max}				10.9	19.0	22.2			
					M _{max}				10.9	19.0	29.0			
					n _{eto}				3479	2159	1593			
14H15-	16.0	1500	6.6	2.50	M ₀				17.3	21.0				
					M _N				16.0	16.0				
					M _{0,max}				25.4	43.9				
					M _{max}				25.4	43.9				
					n _{eto}				1247	800				
14H32-	14.0	3225	11.9	4.70	M ₀					16.2	21.0	21.0		
					M _N					14.0	14.0	14.0		
					M _{0,max}					23.8	28.2	37.1		
					M _{max}					23.8	40.2	51.9		
					n _{eto}					2875	1817	1471		
14L15-	23.0	1500	9.7	3.60	M ₀					28.0	28.0			
					M _N					23.0	23.0			
					M _{0,max}					45.0	52.9			
					M _{max}					45.0	73.8			
					n _{eto}					1126	788			
14L32-	17.2	3225	15.0	5.80	M ₀					15.2	27.4	28.0	28.0	
					M _N					14.9	17.2	17.2	17.2	
					M _{0,max}					23.5	28.3	37.6	52.9	
					M _{max}					23.5	41.0	53.9	73.9	
					n _{eto}					3953	2608	2096	1672	
14P14-	30.0	1350	10.8	4.20	M ₀					37.0	37.0	37.0		
					M _N					30.0	30.0	30.0		
					M _{0,max}					52.5	61.8	80.0		
					M _{max}					52.5	86.3	105.1		
					n _{eto}					998	668	573		

- I... [A], M... [Nm], n... [r/min], P... [kW]

6.11

MCS synchronous servo motors

Technical data



Selection tables, Servo Inverter 9300

Non-ventilated motors

- The data applies to a mains connection voltage of 3 x 400 V and an inverter switching frequency of 8 kHz.

					EVS	9321- E□	9322- E□	9323- E□	9324- E□	9325- E□	9326- E□	9327- E□	9328- E□	9329- E□
					I_N	1.5	2.5	3.9	7.0	13.0	23.5	32.0	47.0	59.0
					$I_{0,max}$	2.3	3.8	5.9	10.5	19.5	23.5	32.0	47.0	52.0
MCS	M_N	n_N	I_N	P_N	I_{max}	2.3	3.8	5.9	10.5	19.5	35.3	48.0	70.5	88.5
14P32-	21.0	3225	15.6	7.10	M_0					19.8	35.8	37.0	37.0	
					M_N					17.5	21.0	21.0	21.0	
					$M_{0,max}$					27.4	33.0	43.9	61.8	
					M_{max}					27.4	47.9	63.0	86.4	
					n_{eto}					3300	2299	1829	1404	
19F14-	27.0	1425	8.6	4.00	M_0				22.6	32.0	32.0			
					M_N				22.0	27.0	27.0			
					$M_{0,max}$				33.0	58.2	68.3			
					M_{max}				33.0	58.2	86.0			
					n_{eto}				1459	1056	746			
19F30-	21.0	3000	14.0	6.60	M_0					21.0	32.0	32.0		
					M_N					19.5	21.0	21.0		
					$M_{0,max}$					29.2	35.2	47.2		
					M_{max}					29.2	51.5	68.3		
					n_{eto}					3352	2573	2033		
19J14-	40.0	1425	12.3	6.00	M_0					43.6	51.0	51.0		
					M_N					40.0	40.0	40.0		
					$M_{0,max}$					60.8	72.4	96.0		
					M_{max}					60.8	104.5	129.0		
					n_{eto}					1376	996	839		
19J30-	29.0	3000	18.5	9.10	M_0						39.3	51.0	51.0	51.0
					M_N						29.0	29.0	29.0	29.0
					$M_{0,max}$						36.8	50.2	72.4	79.5
					M_{max}						55.2	73.8	104.7	127.6
					n_{eto}						3150	2850	2162	1817
19P14-	51.0	1350	14.3	7.20	M_0					47.5	64.0	64.0		
					M_N					46.4	51.0	51.0		
					$M_{0,max}$					69.5	79.6	106.7		
					M_{max}					69.5	116.7	155.5		
					n_{eto}					1400	1187	996		
19P30-	32.0	3000	19.0	10.00	M_0						43.1	58.7	64.0	64.0
					M_N						32.0	32.0	32.0	32.0
					$M_{0,max}$						39.6	53.9	79.6	87.6
					M_{max}						59.3	81.2	116.9	144.3
					n_{eto}						3000	2938	2638	2298

- I... [A], M... [Nm], n... [r/min], P... [kW]

MCS synchronous servo motors

Technical data



Selection tables, Servo Inverter 9300

Forced ventilated IP54 motors

- The data applies to a mains connection voltage of 3 x 400 V and an inverter switching frequency of 8 kHz.

					EVS	9322-E□	9323-E□	9324-E□	9325-E□	9326-E□	9327-E□	9328-E□	9329-E□
					I_N	2.5	3.9	7.0	13.0	23.5	32.0	47.0	59.0
					$I_{0,max}$	3.8	5.9	10.5	19.5	23.5	32.0	47.0	52.0
MCS	M_N	n_N	I_N	P_N	I_{max}	3.8	5.9	10.5	19.5	35.3	48.0	70.5	88.5
12D17-	7.0	1650	3.0	1.20	M_0	5.9	7.5	7.5					
					M_N	5.3	7.0	7.0					
					$M_{0,max}$	7.6	11.6	17.7					
					M_{max}	7.6	11.6	17.7					
					n_{eto}	1790	1358	919					
12D35-	6.0	3525	5.6	2.20	M_0		4.6	7.5	7.5				
					M_N		3.7	6.0	6.0				
					$M_{0,max}$		5.9	10.1	17.3				
					M_{max}		5.9	10.1	17.3				
					n_{eto}		4344	3275	2116				
12H14-	12.0	1350	4.1	1.70	M_0		10.9	12.8	12.8				
					M_N		10.3	12.0	12.0				
					$M_{0,max}$		15.1	25.8	29.0				
					M_{max}		15.1	25.8	29.0				
					n_{eto}		1676	1013	918				
12H34-	10.5	3375	7.5	3.70	M_0			9.8	12.8				
					M_N			9.6	10.5				
					$M_{0,max}$			13.5	24.1				
					M_{max}			13.5	24.1				
					n_{eto}			3618	2447				
12L17-	17.0	1650	6.7	2.90	M_0			18.5	19.0				
					M_N			17.0	17.0				
					$M_{0,max}$			24.4	41.9				
					M_{max}			24.4	41.9				
					n_{eto}			1718	1158				
12L39-	14.0	3900	11.7	5.70	M_0				17.2	19.0	19.0		
					M_N				14.0	14.0	14.0		
					$M_{0,max}$				22.8	27.0	35.5		
					M_{max}				22.8	38.5	49.6		
					n_{eto}				4287	2799	2236		
14D14-	12.0	1350	5.4	1.70	M_0		8.5	12.5	12.5				
					M_N		8.0	12.0	12.0				
					$M_{0,max}$		12.1	20.2	29.0				
					M_{max}		12.1	20.2	29.0				
					n_{eto}		1437	928	676				
14D30-	10.5	3000	9.7	3.30	M_0			7.7	12.5	12.5			
					M_N			7.0	10.0	10.0			
					$M_{0,max}$			10.9	19.0	22.2			
					M_{max}			10.9	19.0	29.0			
					n_{eto}			3479	2159	1593			
14H12-	23.5	1200	8.3	3.00	M_0			17.3	25.5				
					M_N			17.2	23.5				
					$M_{0,max}$			25.4	43.9				
					M_{max}			25.4	43.9				
					n_{eto}			1247	800				

- $I...$ [A], $M...$ [Nm], $n...$ [r/min], $P...$ [kW]

MCS synchronous servo motors

Technical data



Selection tables, Servo Inverter 9300

Forced ventilated IP54 motors

- The data applies to a mains connection voltage of 3 x 400 V and an inverter switching frequency of 8 kHz.

					EVS	9322-E□	9323-E□	9324-E□	9325-E□	9326-E□	9327-E□	9328-E□	9329-E□
					I_N	2.5	3.9	7.0	13.0	23.5	32.0	47.0	59.0
					$I_{0,max}$	3.8	5.9	10.5	19.5	23.5	32.0	47.0	52.0
MCS	M_N	n_N	I_N	P_N	I_{max}	3.8	5.9	10.5	19.5	35.3	48.0	70.5	88.5
14H28-	20.5	2775	15.0	6.00	M_0				16.2	25.5	25.5		
					M_N				16.1	20.5	20.5		
					$M_{0,max}$				23.8	28.2	37.1		
					M_{max}				23.8	40.2	51.9		
					n_{eto}					2875	1817	1471	
14L14-	30.5	1350	11.8	4.30	M_0				33.4	34.5			
					M_N				30.5	30.5			
					$M_{0,max}$				45.0	52.9			
					M_{max}				45.0	73.8			
					n_{eto}					1126	788		
14L30-	25.5	3000	20.8	8.00	M_0					27.4	34.5	34.5	
					M_N					25.5	25.5	25.5	
					$M_{0,max}$					28.3	37.6	52.9	
					M_{max}					41.0	53.9	73.9	
					n_{eto}						2608	2096	1672
14P11-	42.0	1050	13.4	4.60	M_0				40.1	43.5	43.5		
					M_N				40.0	42.0	42.0		
					$M_{0,max}$				52.5	61.8	80.0		
					M_{max}				52.5	86.3	105.1		
					n_{eto}					998	668	573	
14P26-	33.0	2625	21.9	9.10	M_0					35.8	43.5	43.5	
					M_N					33.0	33.0	33.0	
					$M_{0,max}$					33.0	43.9	61.8	
					M_{max}					47.9	63.0	86.4	
					n_{eto}						2299	1829	1404
19F12-	38.0	1200	11.3	4.80	M_0			22.6	41.5	41.5			
					M_N				22.0	38.0	38.0		
					$M_{0,max}$				33.0	58.2	68.3		
					M_{max}				33.0	58.2	86.0		
					n_{eto}					1459	1056	746	
19F29-	32.5	2850	20.1	9.70	M_0					39.9	41.5		
					M_N					32.5	32.5		
					$M_{0,max}$					35.2	47.2		
					M_{max}					51.5	68.3		
					n_{eto}						2573	2033	
19J12-	62.5	1200	18.3	7.90	M_0				43.6	70.5	70.5		
					M_N				43.4	62.5	62.5		
					$M_{0,max}$				60.8	72.4	96.0		
					M_{max}				60.8	104.5	129.0		
					n_{eto}					1376	996	839	
19J29-	50.5	2850	31.0	15.10	M_0						55.5	70.5	70.5
					M_N						50.5	50.5	50.5
					$M_{0,max}$						50.2	72.4	79.5
					M_{max}						73.8	104.7	127.6
					n_{eto}						2850	2162	1817

- $I...$ [A], $M...$ [Nm], $n...$ [r/min], $P...$ [kW]

MCS synchronous servo motors

Technical data



Selection tables, Servo Inverter 9300

Forced ventilated IP54 motors

- The data applies to a mains connection voltage of 3 x 400 V and an inverter switching frequency of 8 kHz.

					EVS	9322-E□	9323-E□	9324-E□	9325-E□	9326-E□	9327-E□	9328-E□	9329-E□
					I_N	2.5	3.9	7.0	13.0	23.5	32.0	47.0	59.0
					$I_{0,max}$	3.8	5.9	10.5	19.5	23.5	32.0	47.0	52.0
MCS	M_N	n_N	I_N	P_N	I_{max}	3.8	5.9	10.5	19.5	35.3	48.0	70.5	88.5
19P12-	72.0	1200	21.3	9.00	M_0				47.5	86.0	86.0		
					M_N				46.4	72.0	72.0		
					$M_{0,max}$				69.5	79.6	106.7		
					M_{max}				69.5	116.7	155.5		
					n_{eto}				1400	1187	996		
19P29-	53.0	2850	29.5	15.80	M_0						58.7	86.0	86.0
					M_N						53.0	53.0	53.0
					$M_{0,max}$						53.9	79.6	87.6
					M_{max}						81.2	116.9	144.3
					n_{eto}						2938	2638	2298

- I... [A], M... [Nm], n... [r/min], P... [kW]

MCS synchronous servo motors

Technical data



Torque characteristics

- ▶ The data applies to a mains connection voltage of 3 x 400 V.
- ▶ You can find further torque characteristics at www.lenze.de/dsc.

MCS06C41- (non-ventilated)

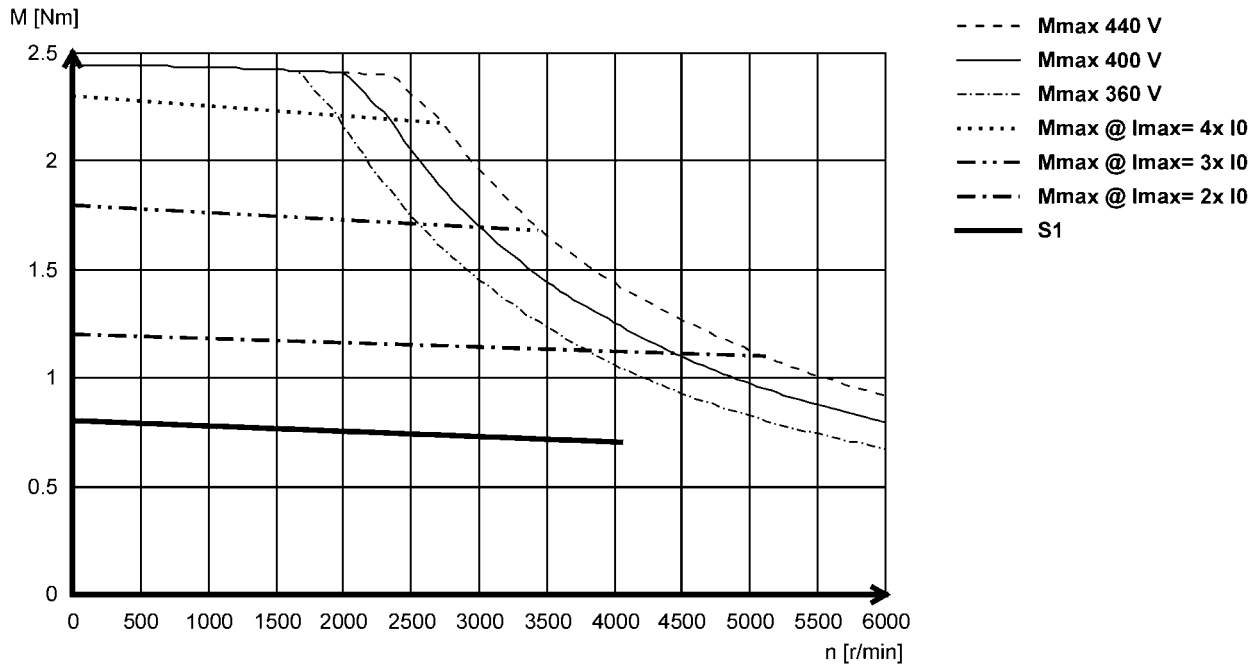

MCS06C60- (non-ventilated)

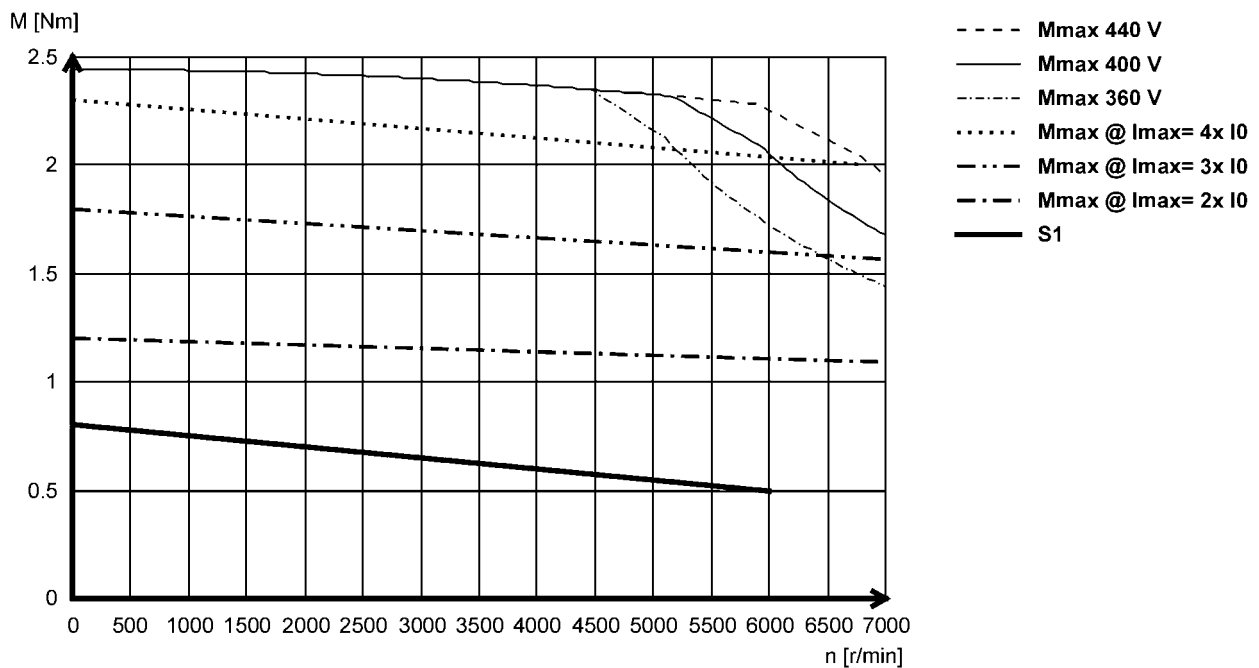

MCS synchronous servo motors

Technical data



Torque characteristics

- ▶ The data applies to a mains connection voltage of 3 x 400 V.
- ▶ You can find further torque characteristics at www.lenze.de/dsc.

MCS06F41- (non-ventilated)

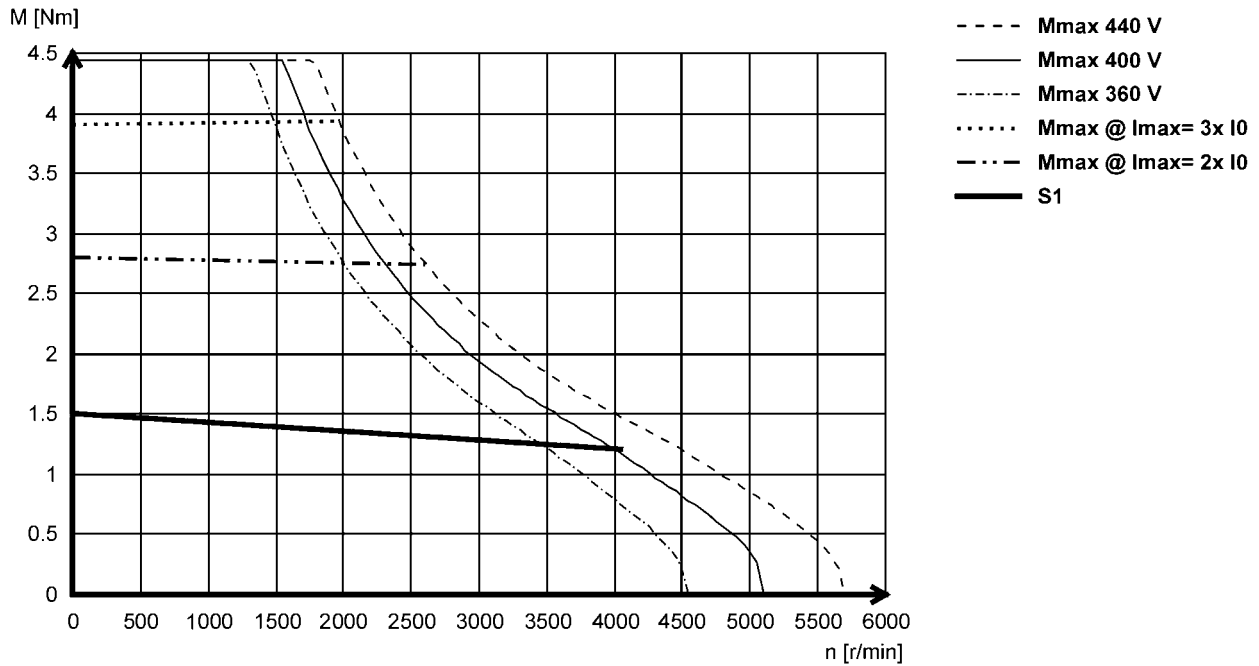

MCS06F60- (non-ventilated)

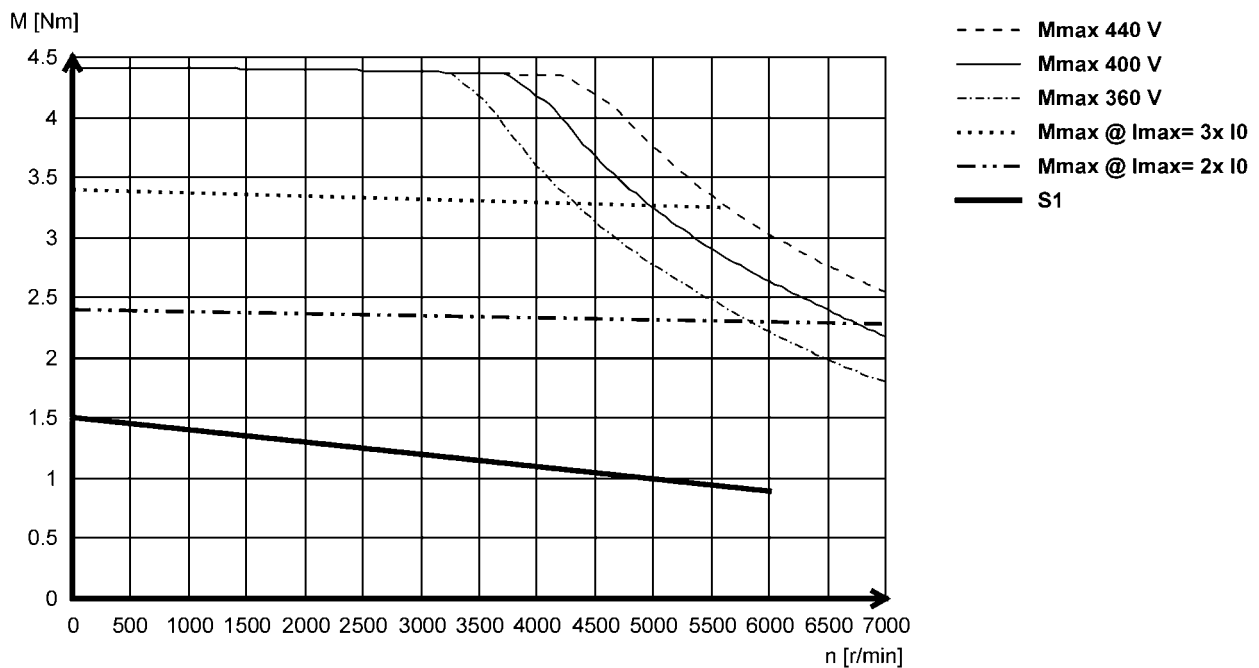

MCS synchronous servo motors

Technical data



Torque characteristics

- ▶ The data applies to a mains connection voltage of 3 x 400 V.
- ▶ You can find further torque characteristics at www.lenze.de/dsc.

MCS06I41- (non-ventilated)

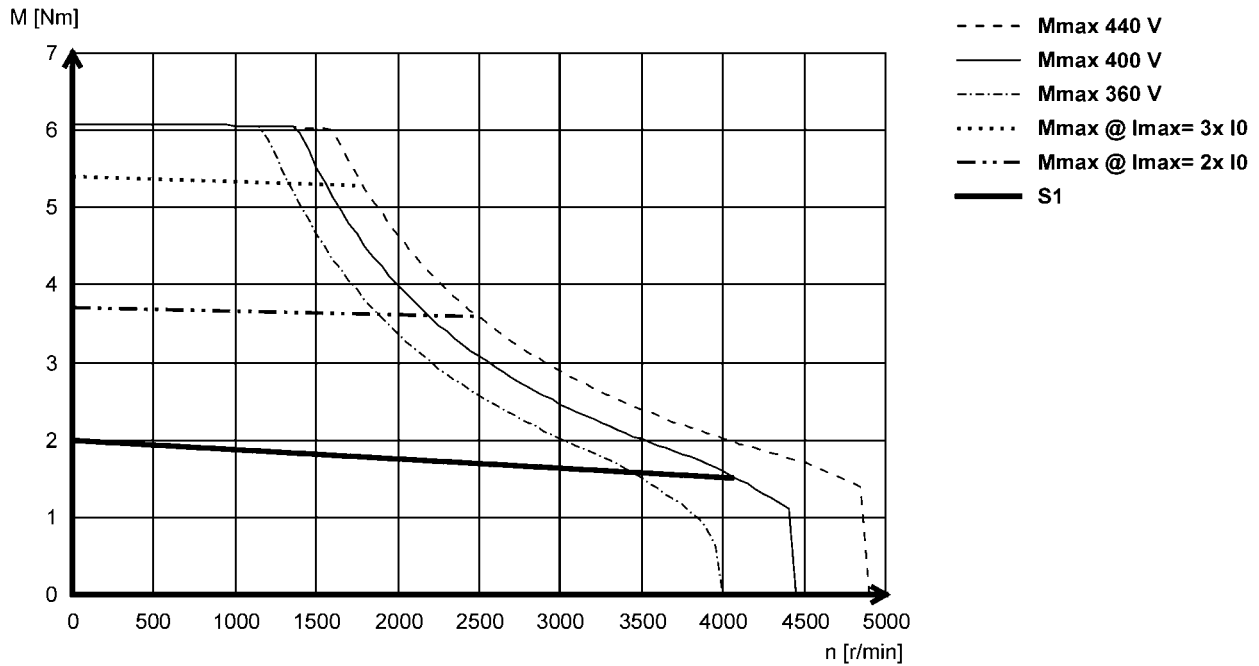

MCS06I60- (non-ventilated)

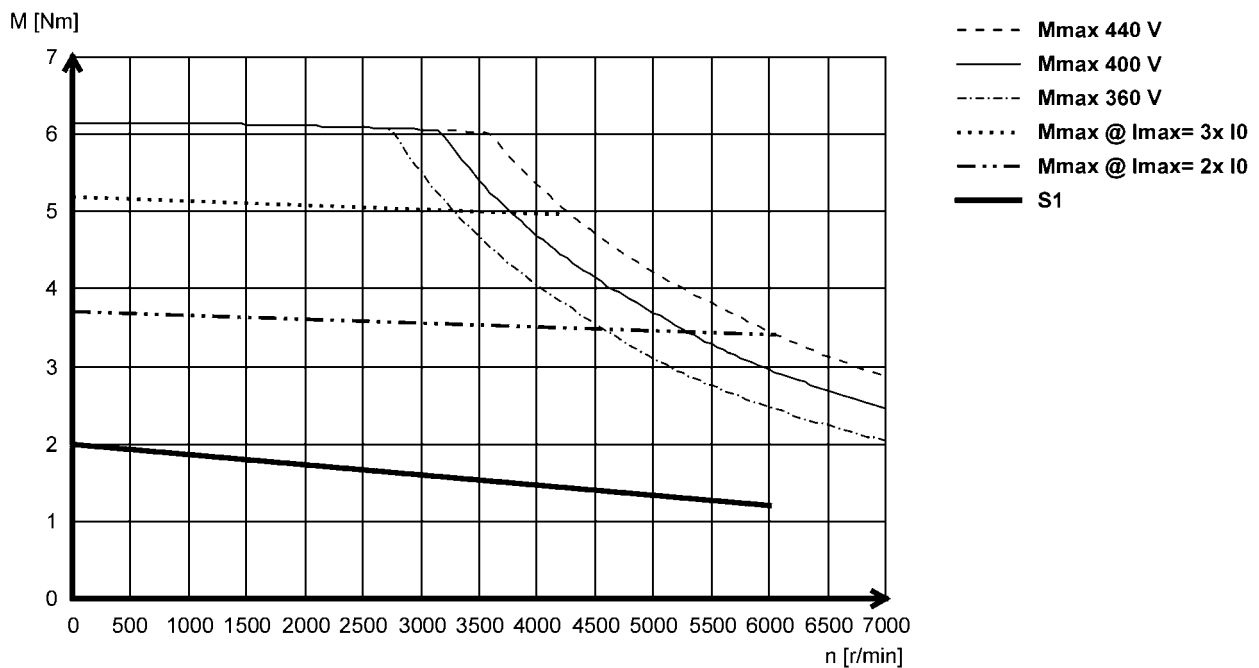

MCS synchronous servo motors

Technical data



Torque characteristics

- ▶ The data applies to a mains connection voltage of 3 x 400 V.
- ▶ You can find further torque characteristics at www.lenze.de/dsc.

MCS09D41- (non-ventilated)

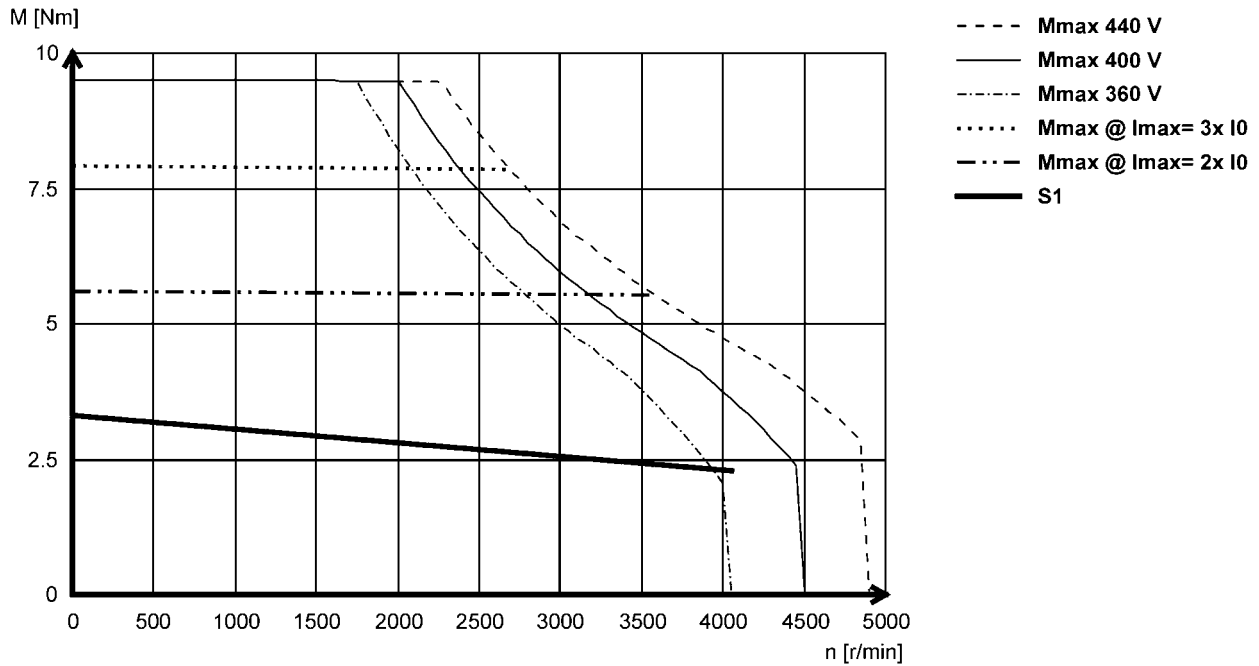

MCS09D60- (non-ventilated)

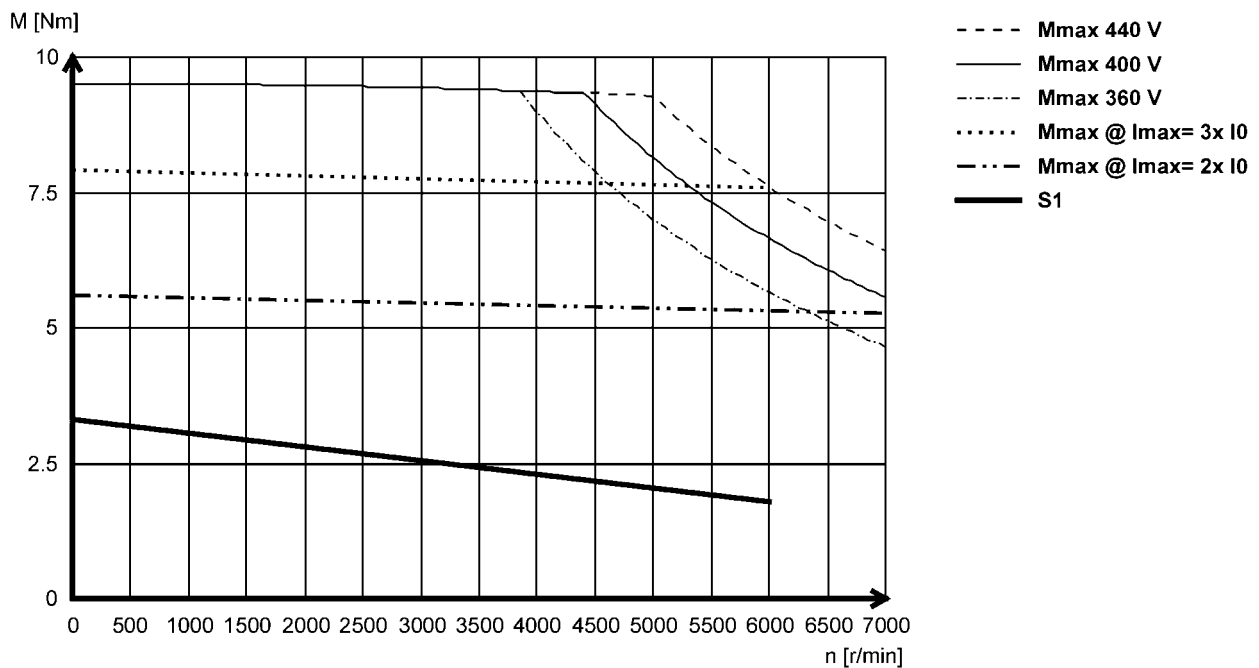

MCS synchronous servo motors

Technical data



Torque characteristics

- ▶ The data applies to a mains connection voltage of 3 x 400 V.
- ▶ You can find further torque characteristics at www.lenze.de/dsc.

MCS09F38- (non-ventilated)

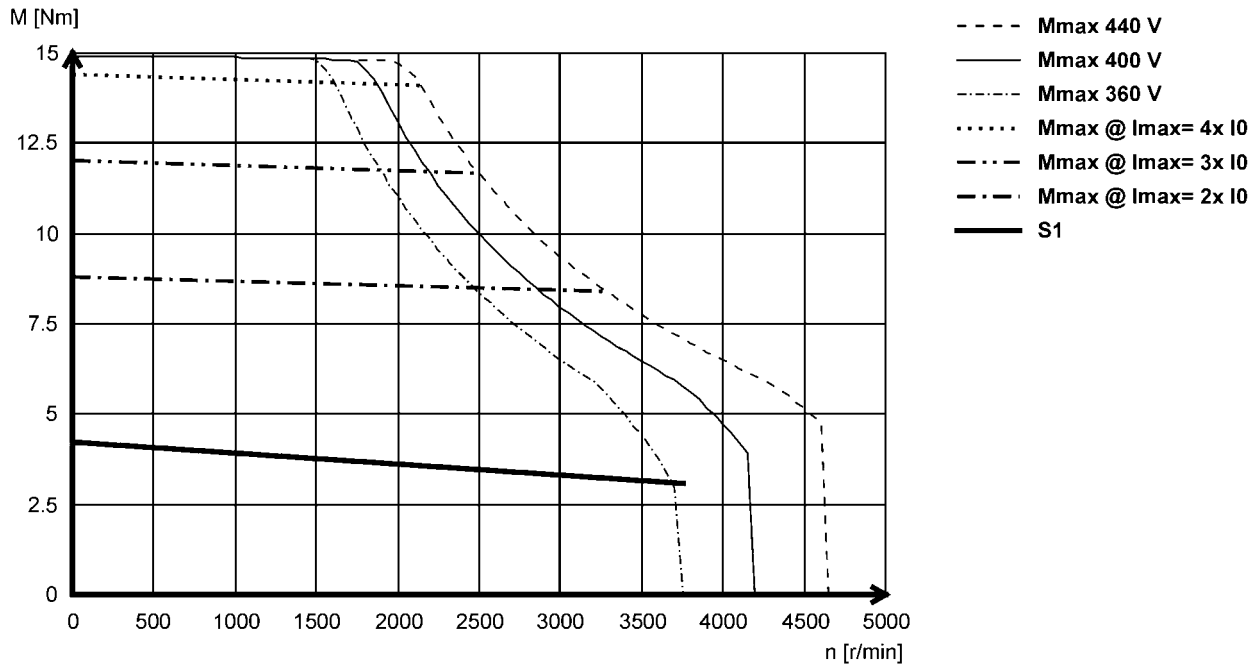

MCS09F60- (non-ventilated)

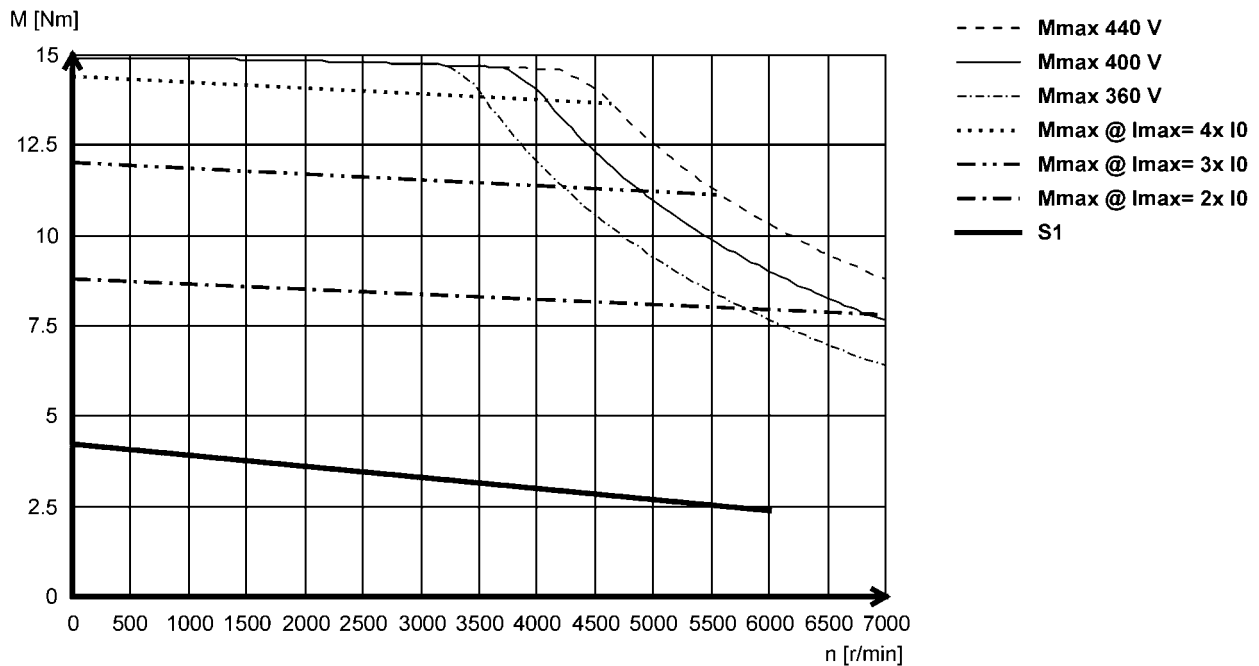

MCS synchronous servo motors

Technical data



Torque characteristics

- ▶ The data applies to a mains connection voltage of 3 x 400 V.
- ▶ You can find further torque characteristics at www.lenze.de/dsc.

MCS09H41- (non-ventilated)

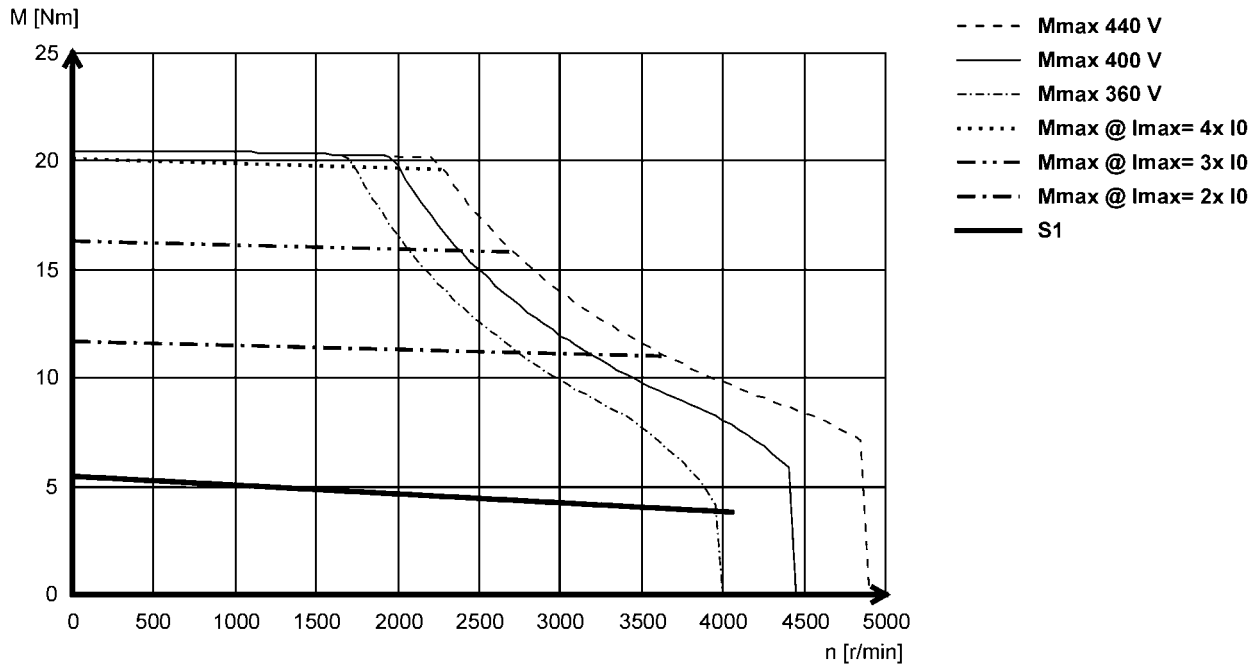

MCS09H60- (non-ventilated)

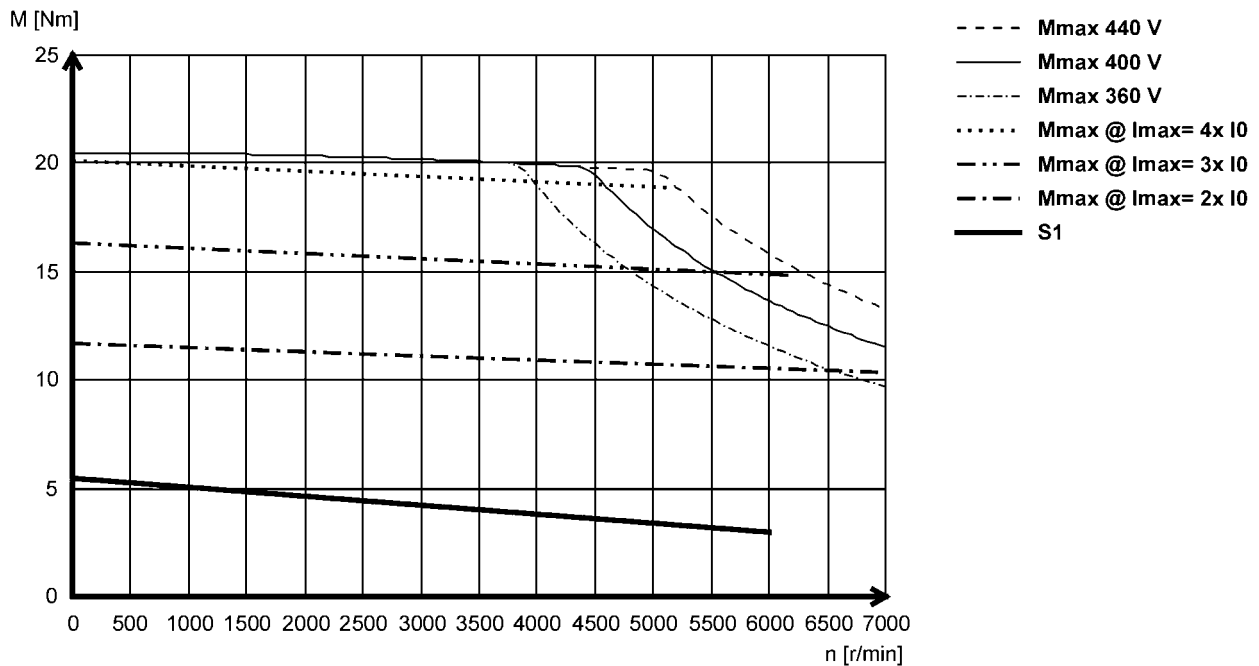

MCS synchronous servo motors

Technical data



Torque characteristics

- ▶ The data applies to a mains connection voltage of 3 x 400 V.
- ▶ You can find further torque characteristics at www.lenze.de/dsc.

MCS09L41- (non-ventilated)

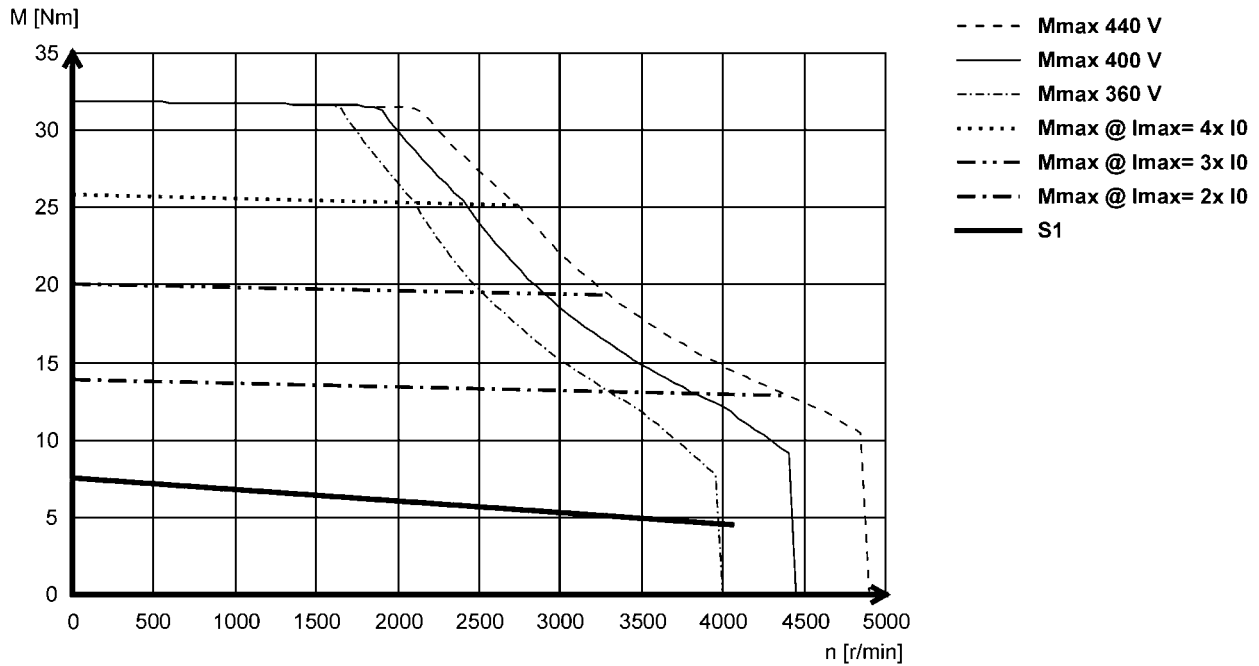

MCS09L51- (non-ventilated)

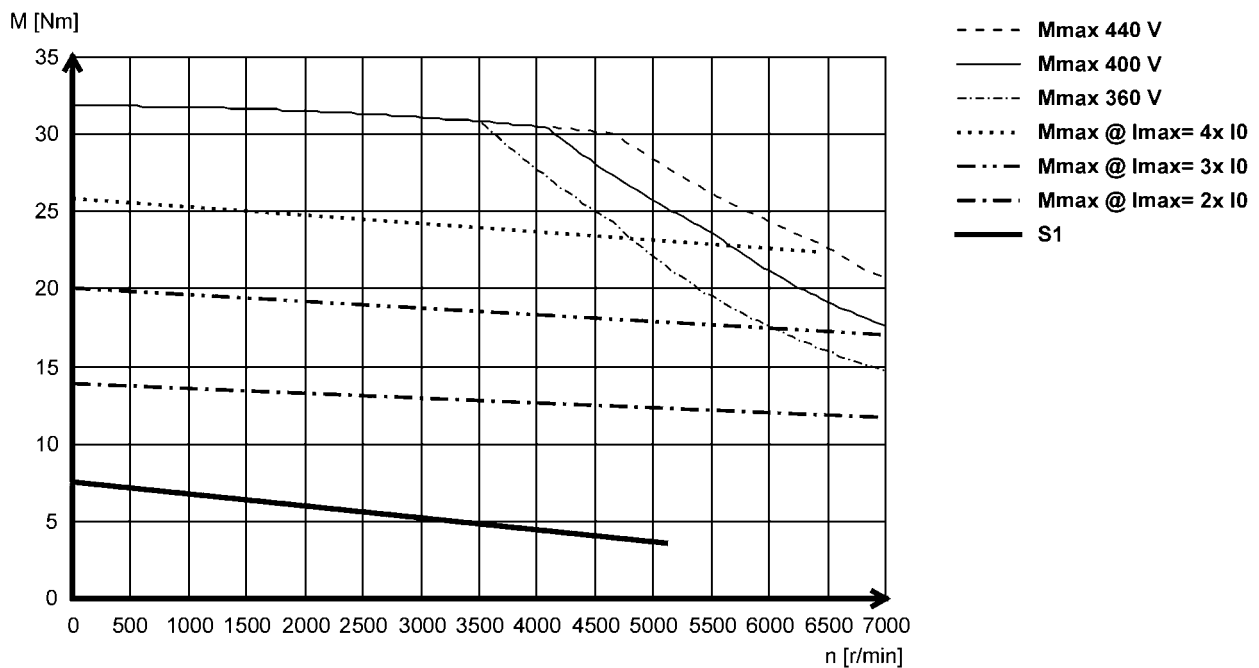

MCS synchronous servo motors

Technical data



Torque characteristics

- ▶ The data applies to a mains connection voltage of 3 x 400 V.
- ▶ You can find further torque characteristics at www.lenze.de/dsc.

MCS12D17 (forced ventilated)

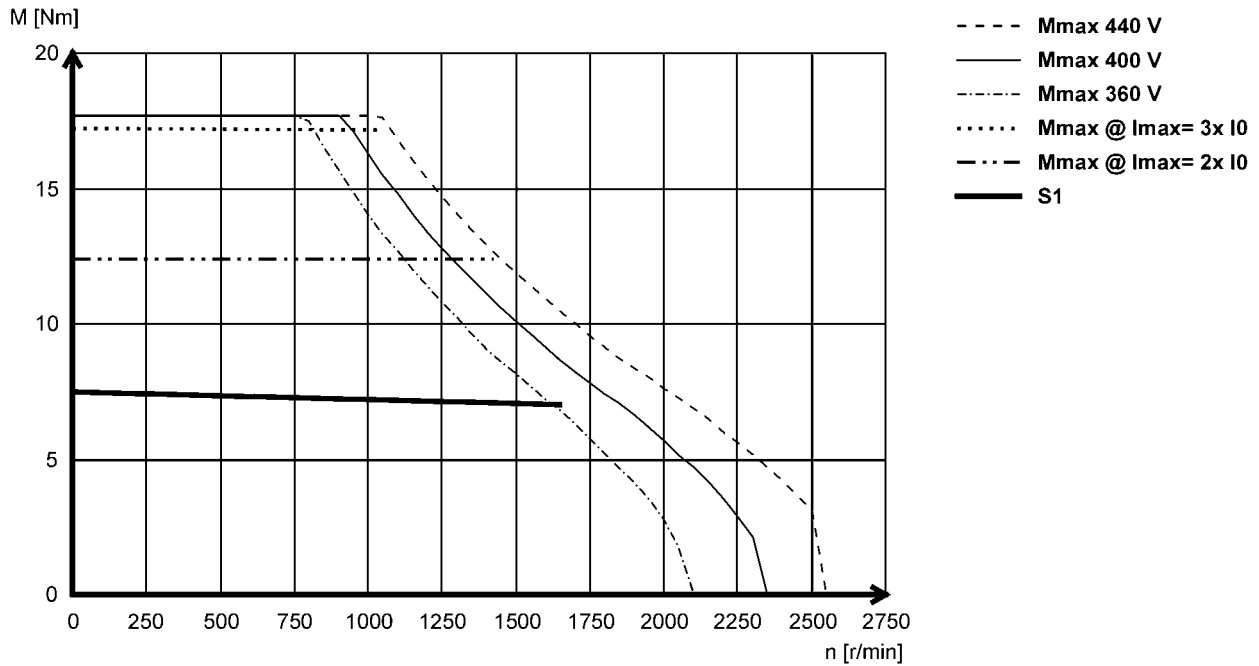

MCS12D20- (non-ventilated)

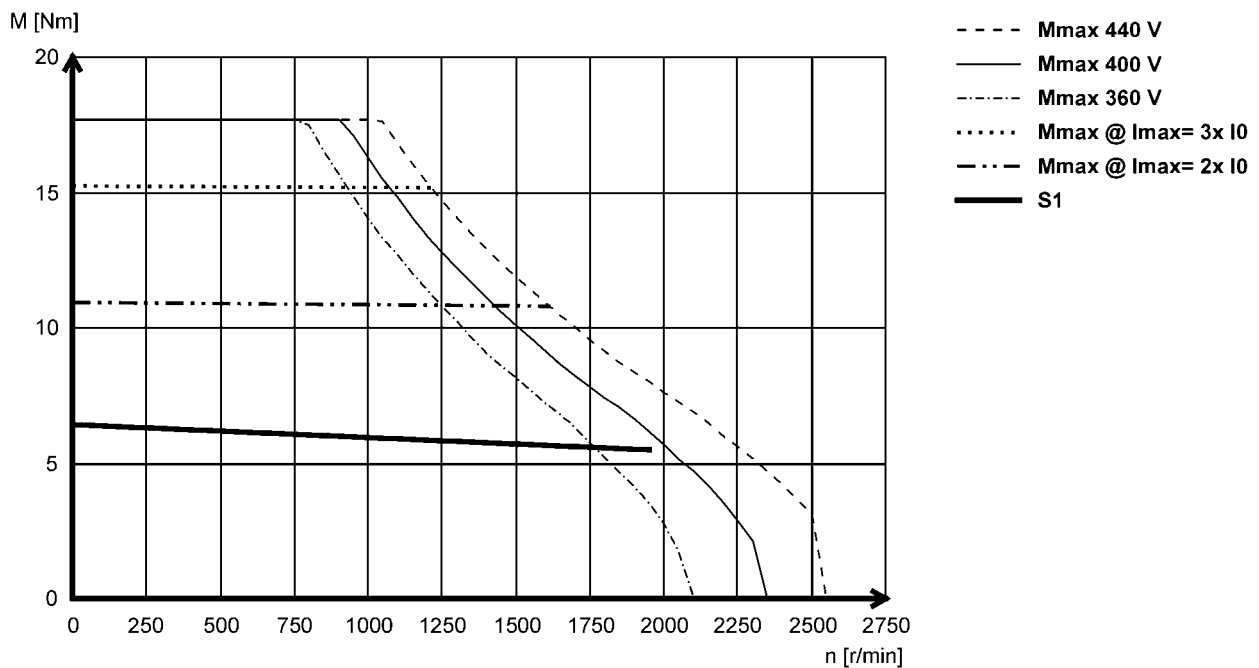

MCS synchronous servo motors

Technical data



Torque characteristics

- ▶ The data applies to a mains connection voltage of 3 x 400 V.
- ▶ You can find further torque characteristics at www.lenze.de/dsc.

MCS12D35- (forced ventilated)

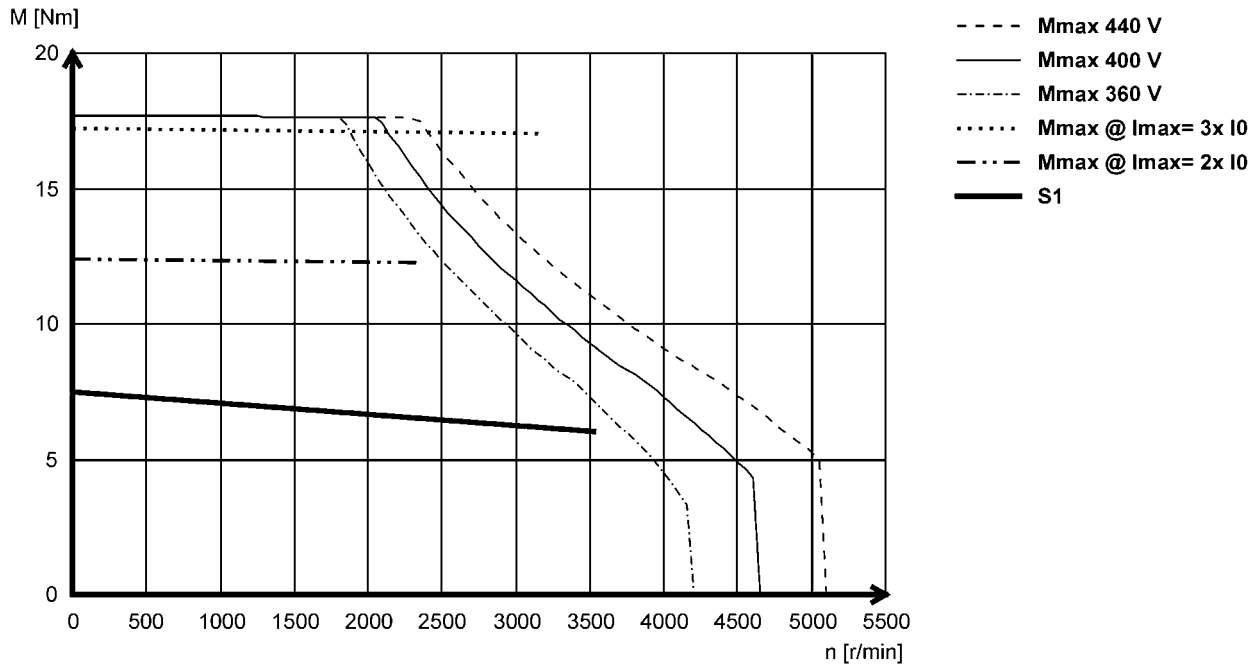

MCS12D41- (non-ventilated)

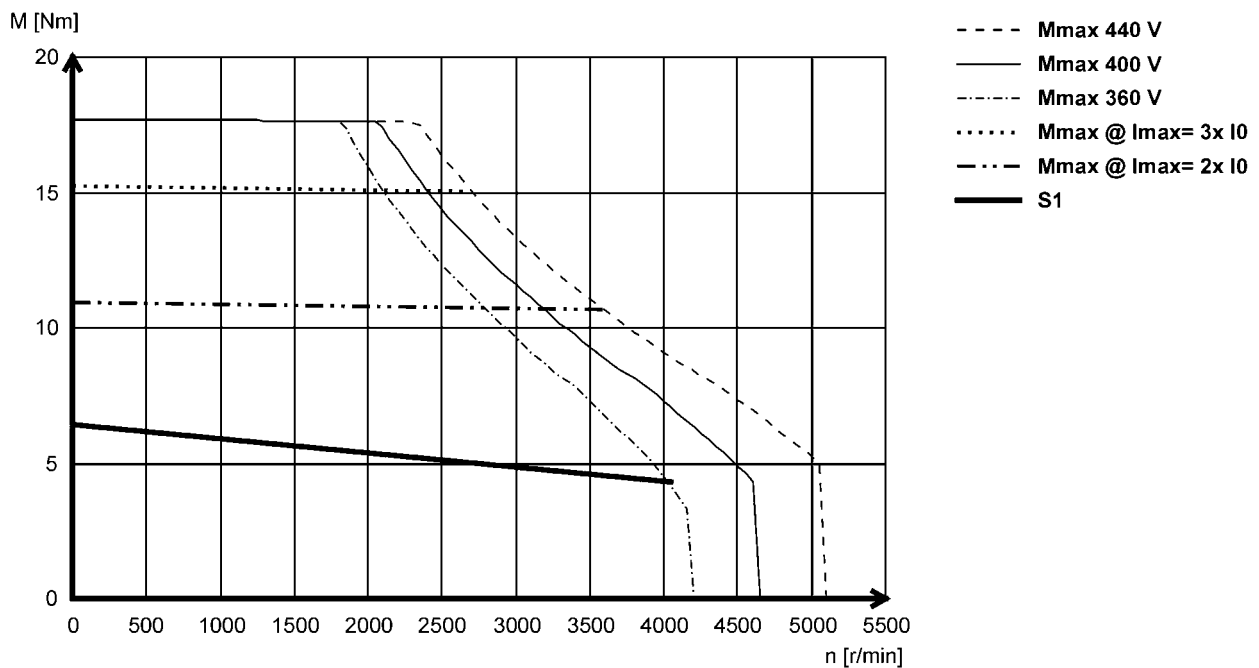

MCS synchronous servo motors

Technical data



Torque characteristics

- ▶ The data applies to a mains connection voltage of 3 x 400 V.
- ▶ You can find further torque characteristics at www.lenze.de/dsc.

MCS12H14- (forced ventilated)

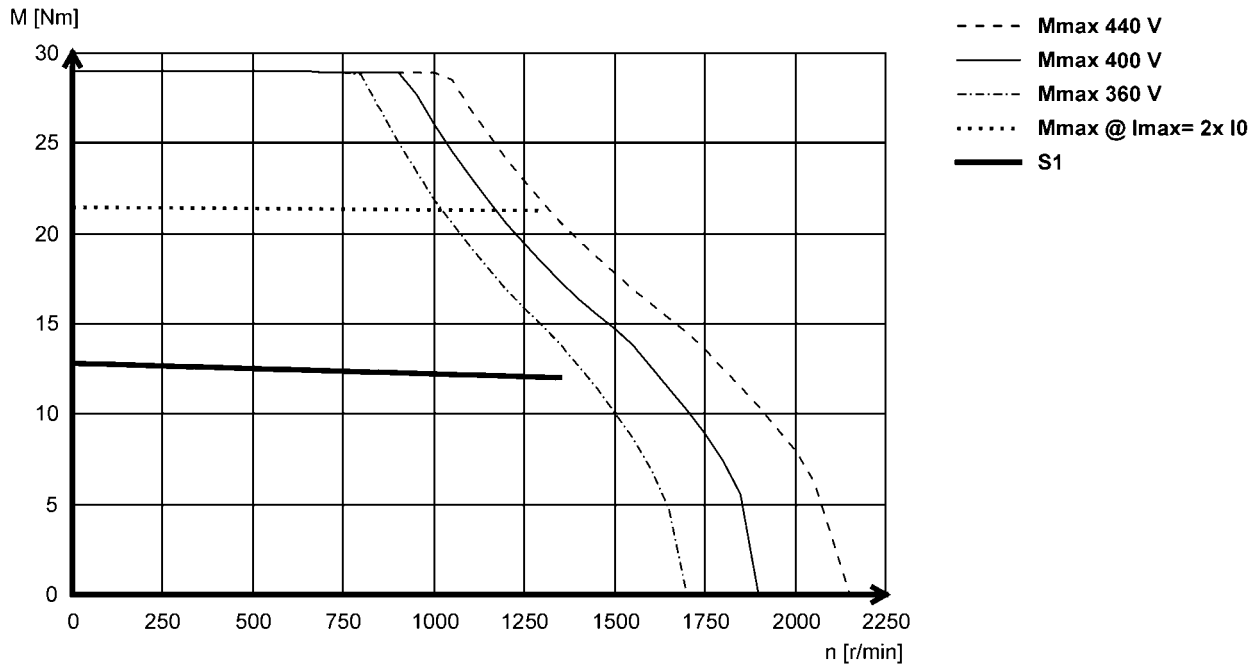

MCS12H15- (non-ventilated)

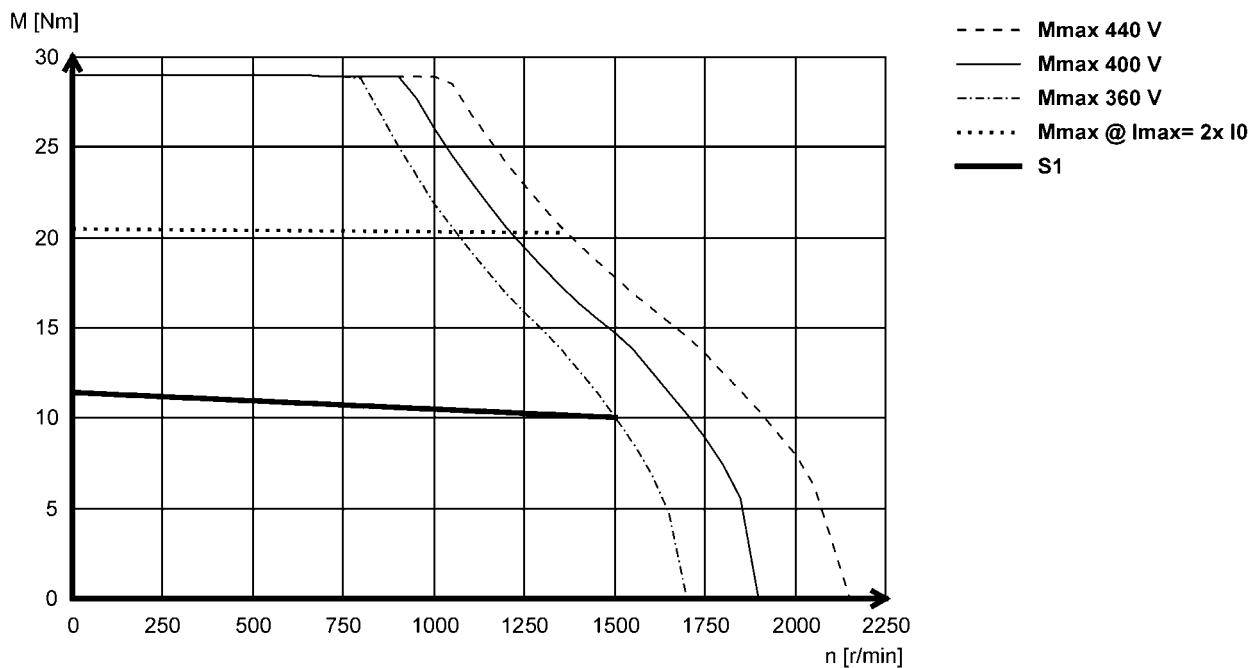

MCS synchronous servo motors

Technical data



Torque characteristics

- ▶ The data applies to a mains connection voltage of 3 x 400 V.
- ▶ You can find further torque characteristics at www.lenze.de/dsc.

MCS12H34- (forced ventilated)

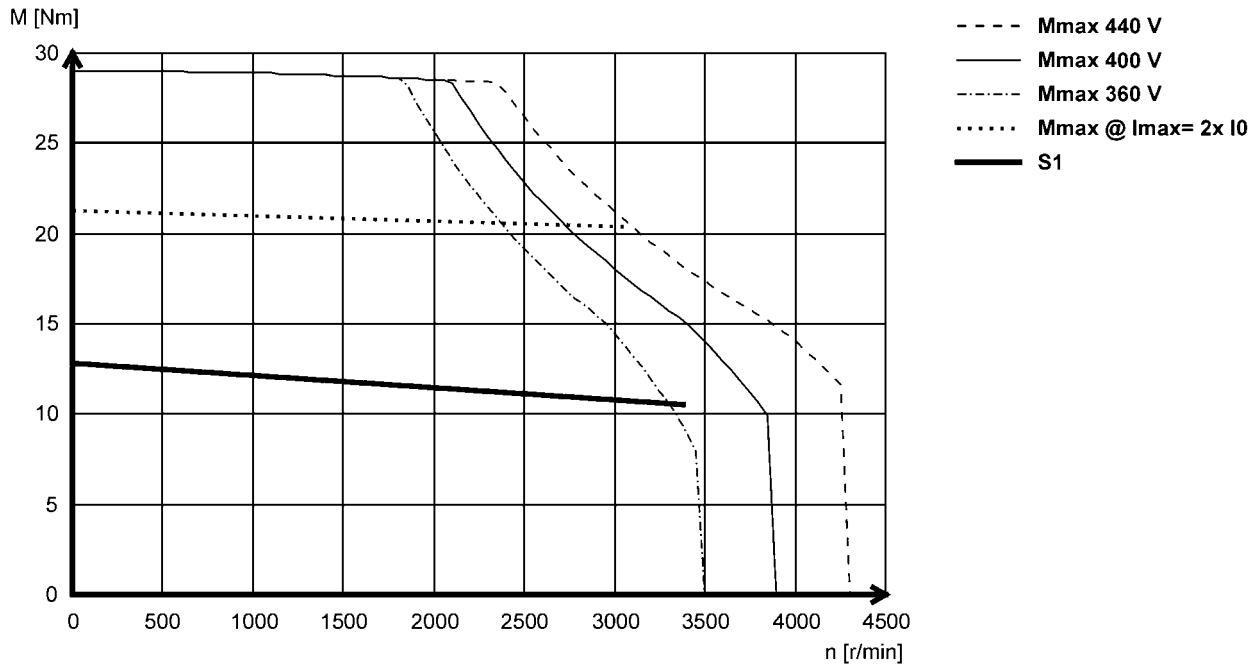

MCS12H35- (non-ventilated)

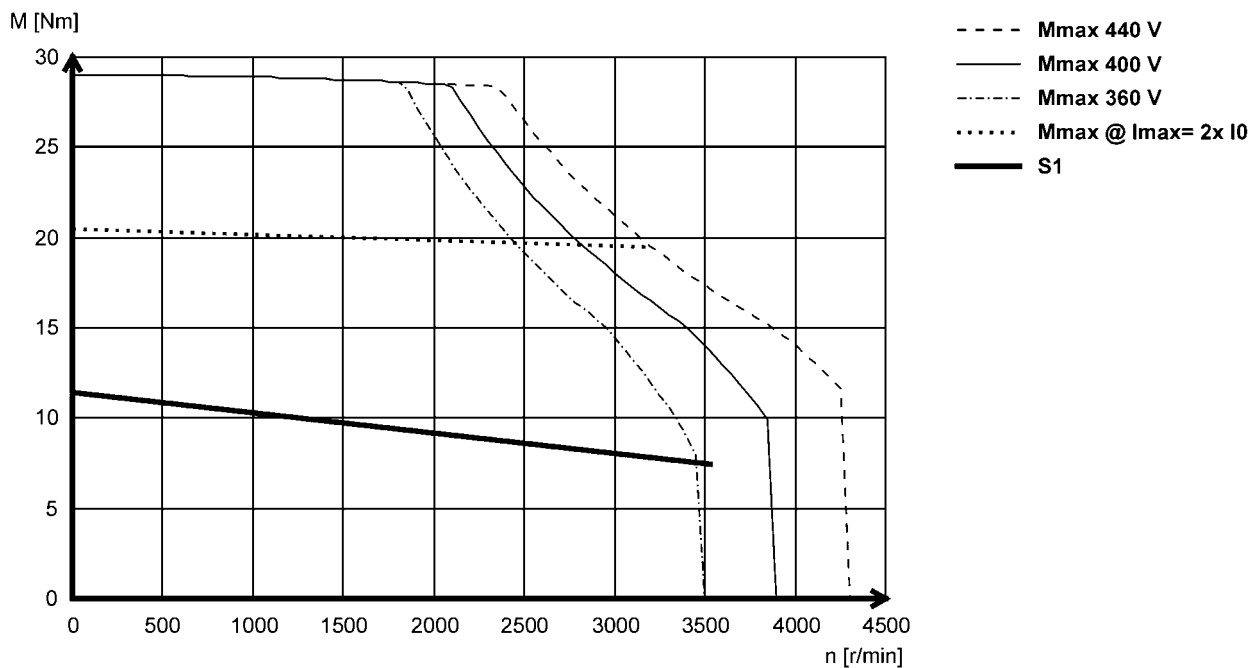

MCS synchronous servo motors

Technical data



Torque characteristics

- ▶ The data applies to a mains connection voltage of 3 x 400 V.
- ▶ You can find further torque characteristics at www.lenze.de/dsc.

MCS12L17- (forced ventilated)

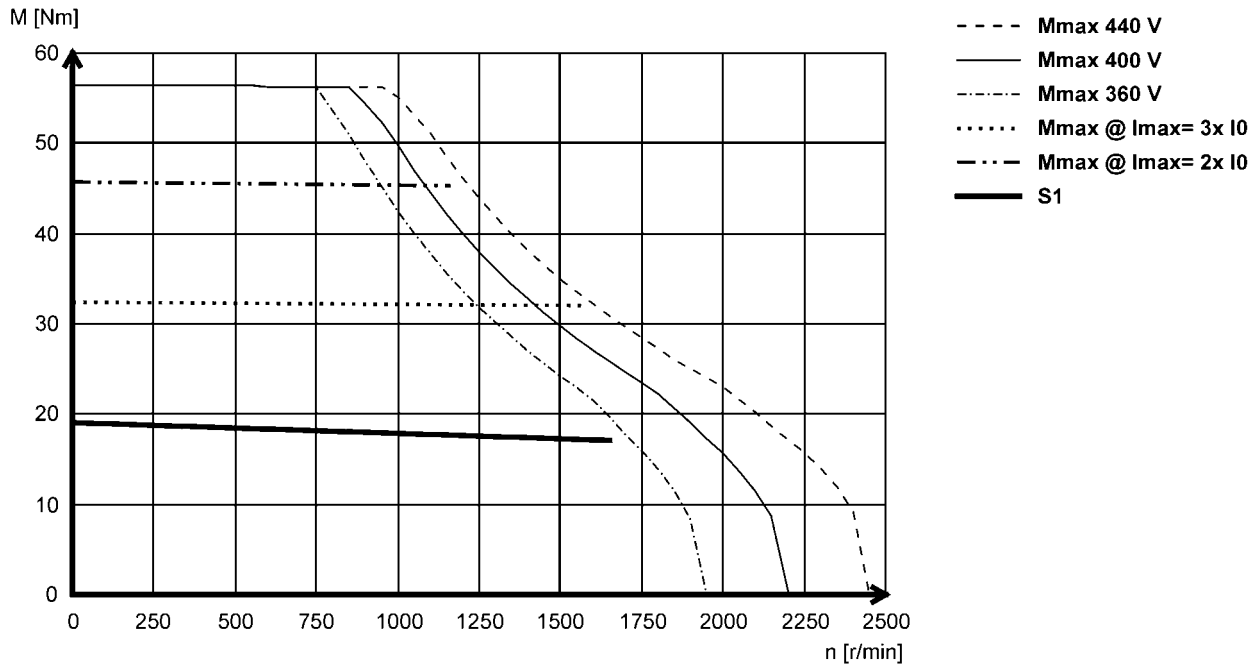

MCS12L20- (non-ventilated)

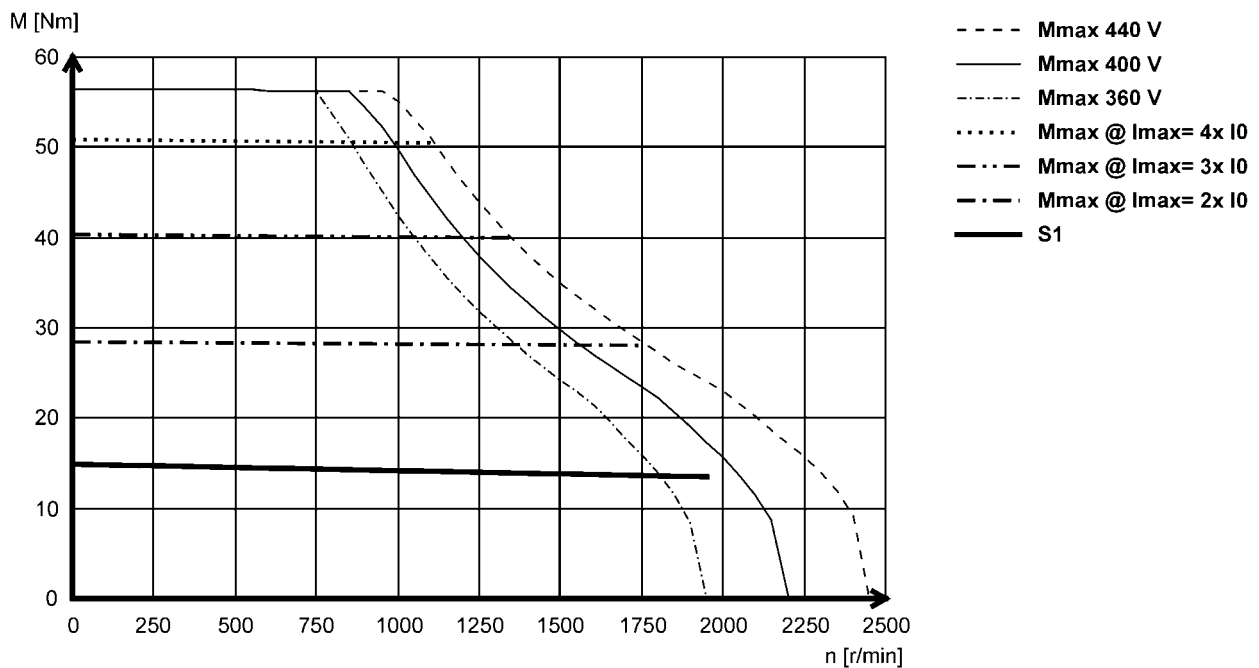

MCS synchronous servo motors

Technical data



Torque characteristics

- ▶ The data applies to a mains connection voltage of 3 x 400 V.
- ▶ You can find further torque characteristics at www.lenze.de/dsc.

MCS12L39- (forced ventilated)

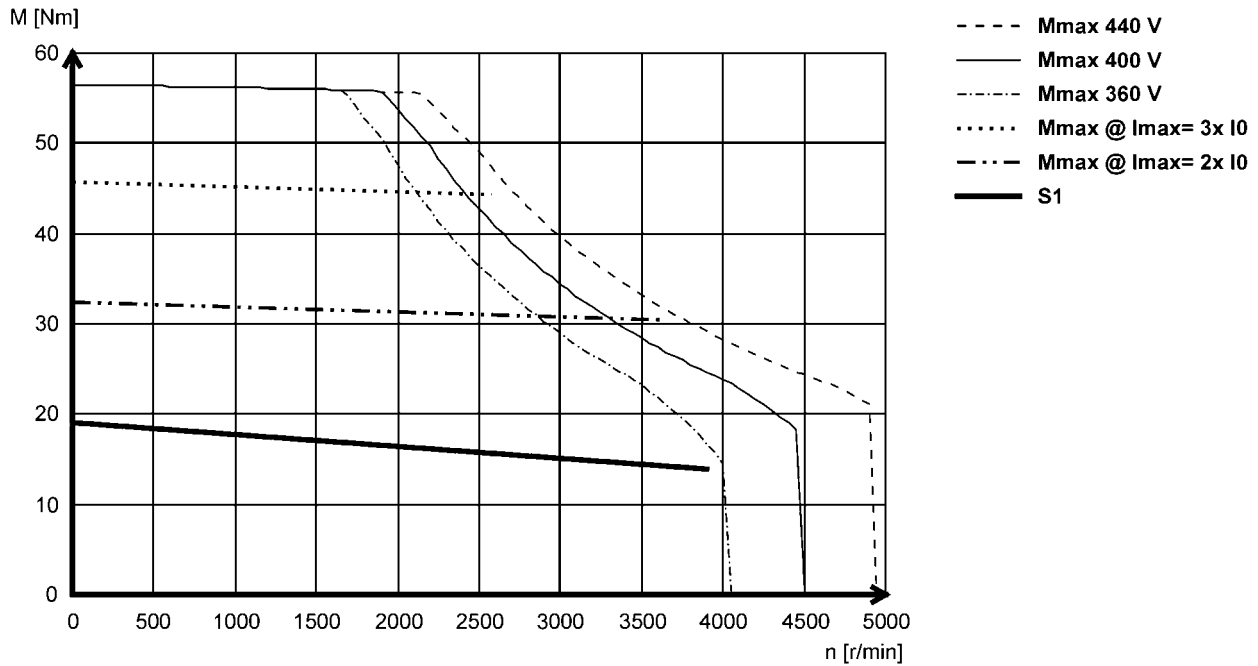

MCS12L41- (non-ventilated)

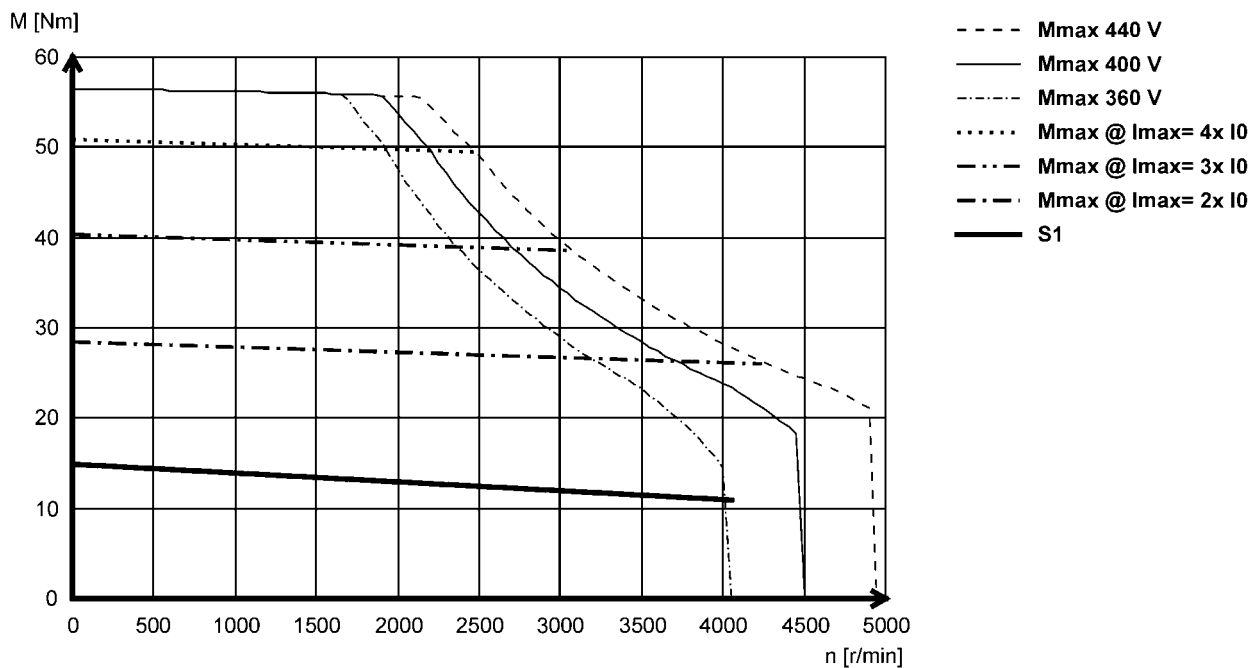

MCS synchronous servo motors

Technical data



Torque characteristics

- ▶ The data applies to a mains connection voltage of 3 x 400 V.
- ▶ You can find further torque characteristics at www.lenze.de/dsc.

MCS14D14- (forced ventilated)

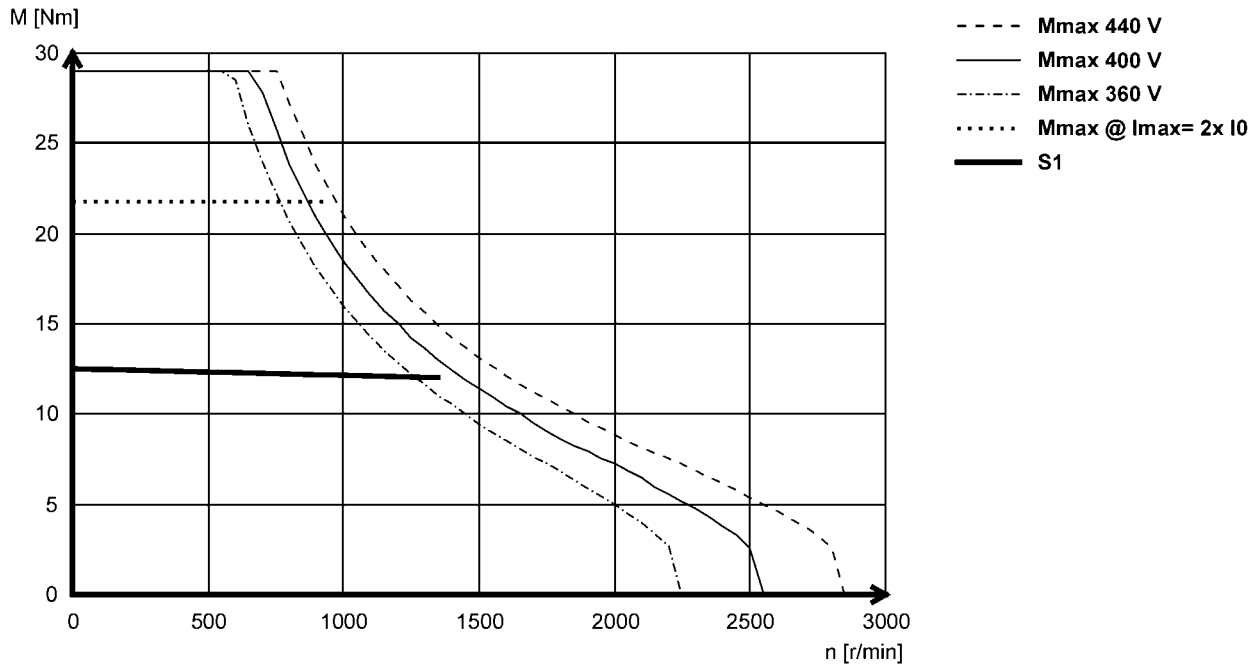

MCS14D15- (non-ventilated)

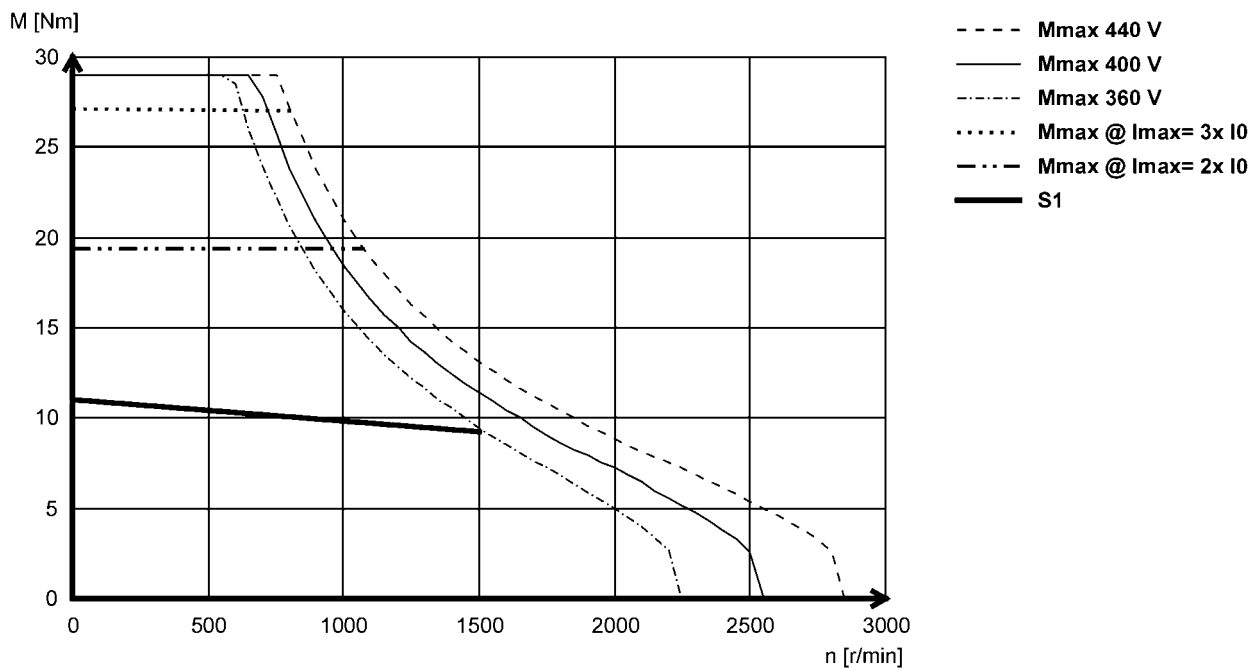

MCS synchronous servo motors

Technical data



Torque characteristics

- ▶ The data applies to a mains connection voltage of 3 x 400 V.
- ▶ You can find further torque characteristics at www.lenze.de/dsc.

MCS14D30 (forced ventilated)

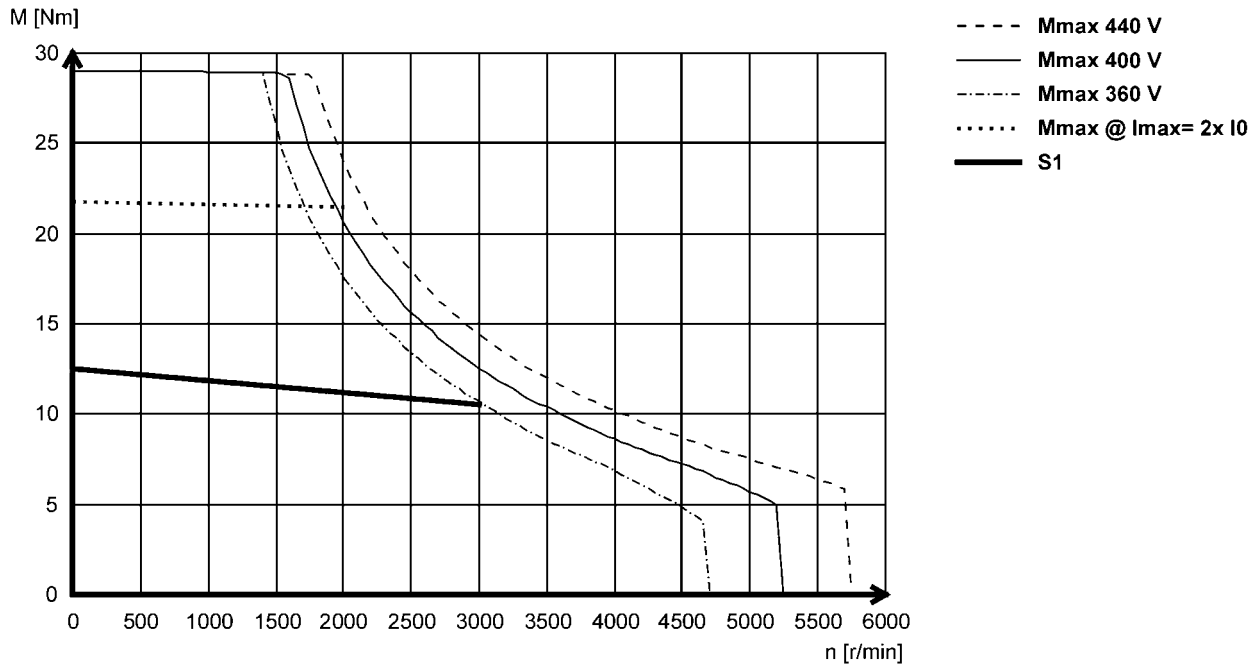

MCS14D36- (non-ventilated)

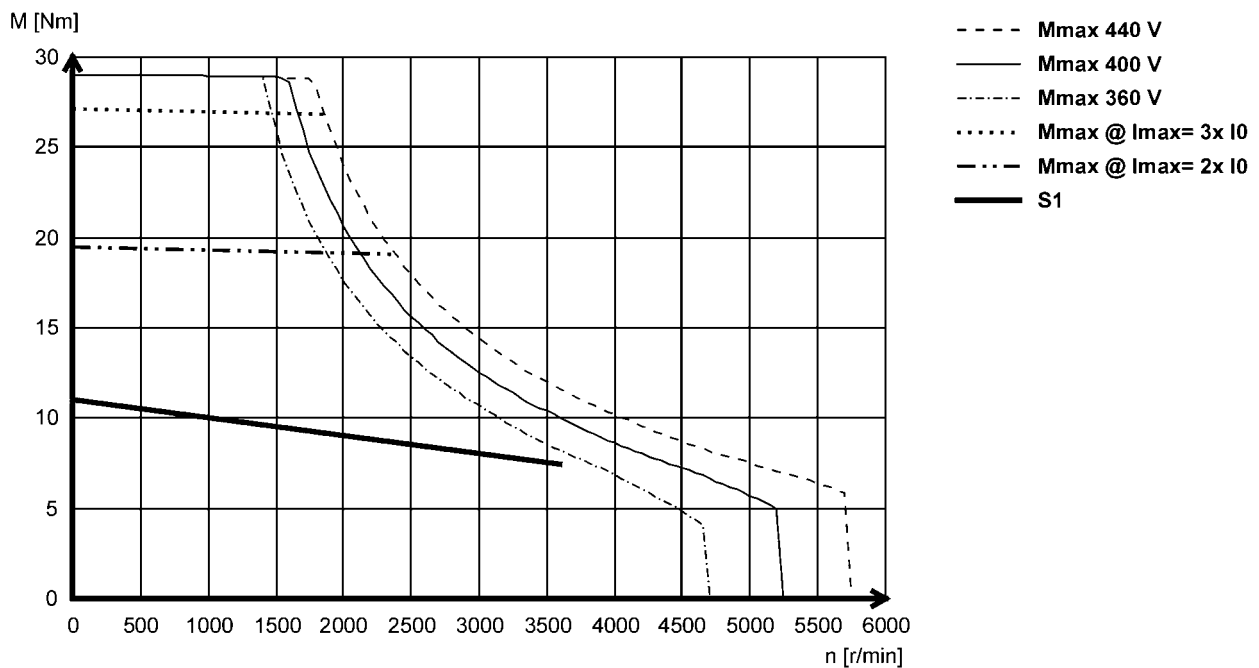

MCS synchronous servo motors

Technical data



Torque characteristics

- ▶ The data applies to a mains connection voltage of 3 x 400 V.
- ▶ You can find further torque characteristics at www.lenze.de/dsc.

MCS14H12- (forced ventilated)

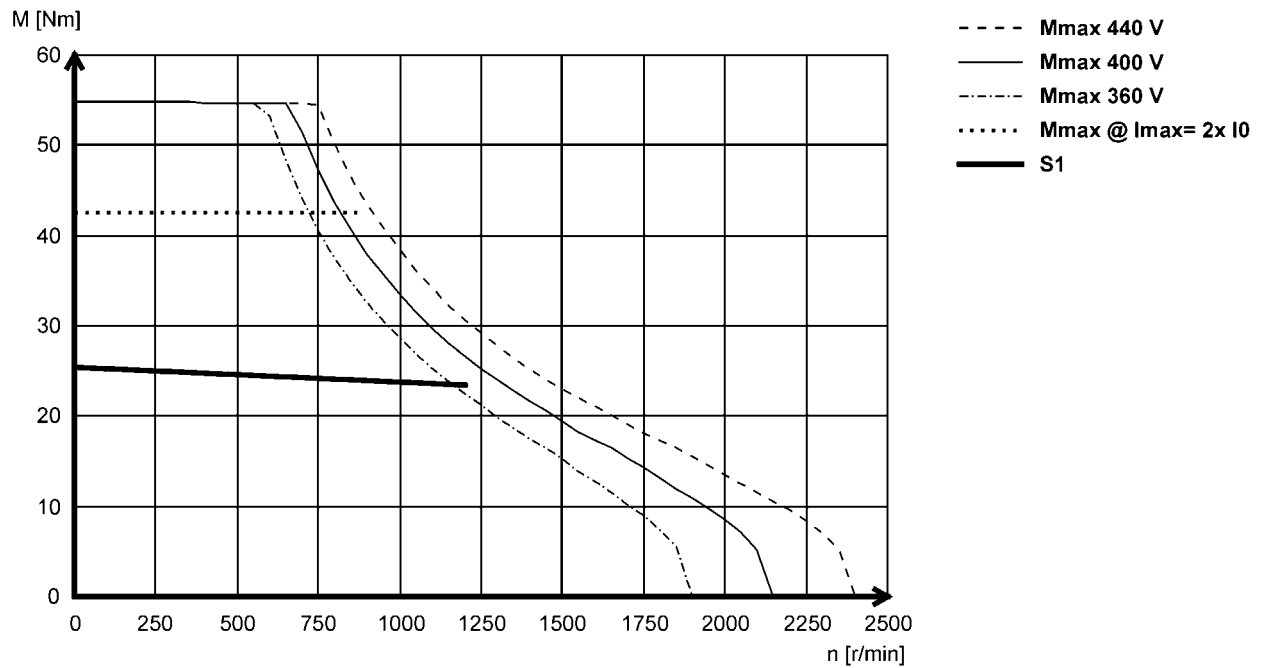

MCS14H15- (non-ventilated)

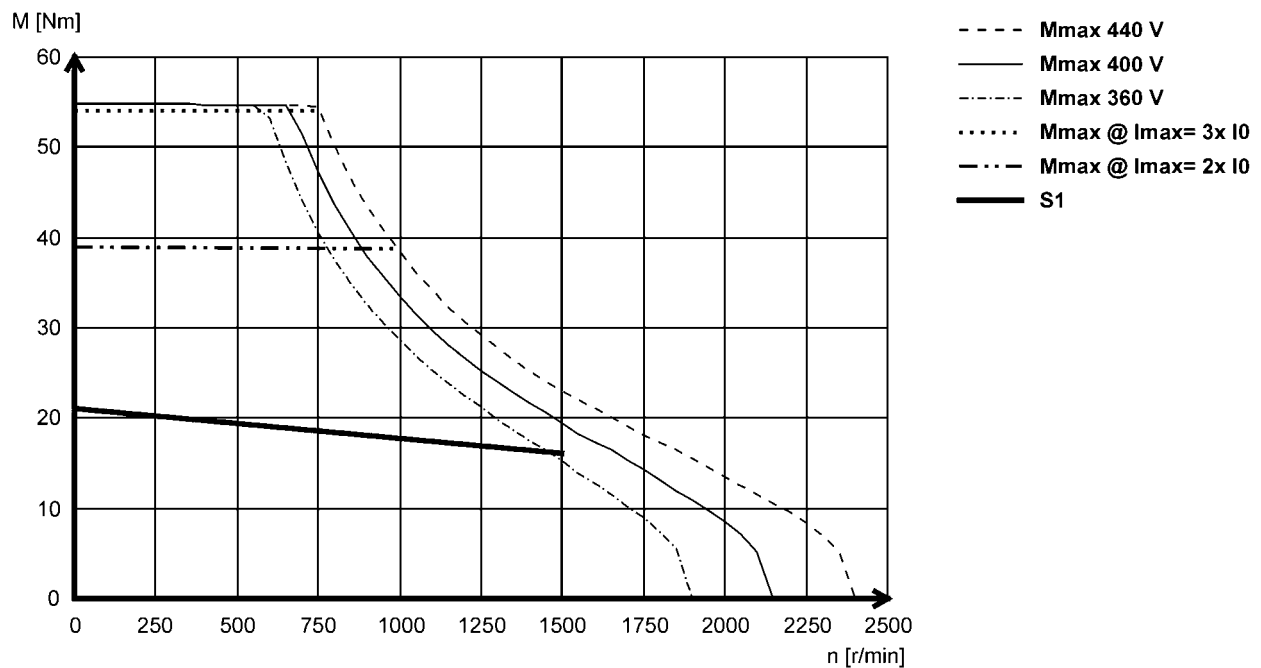

6.11

MCS synchronous servo motors

Technical data



Torque characteristics

- ▶ The data applies to a mains connection voltage of 3 x 400 V.
- ▶ You can find further torque characteristics at www.lenze.de/dsc.

MCS14H28- (forced ventilated)

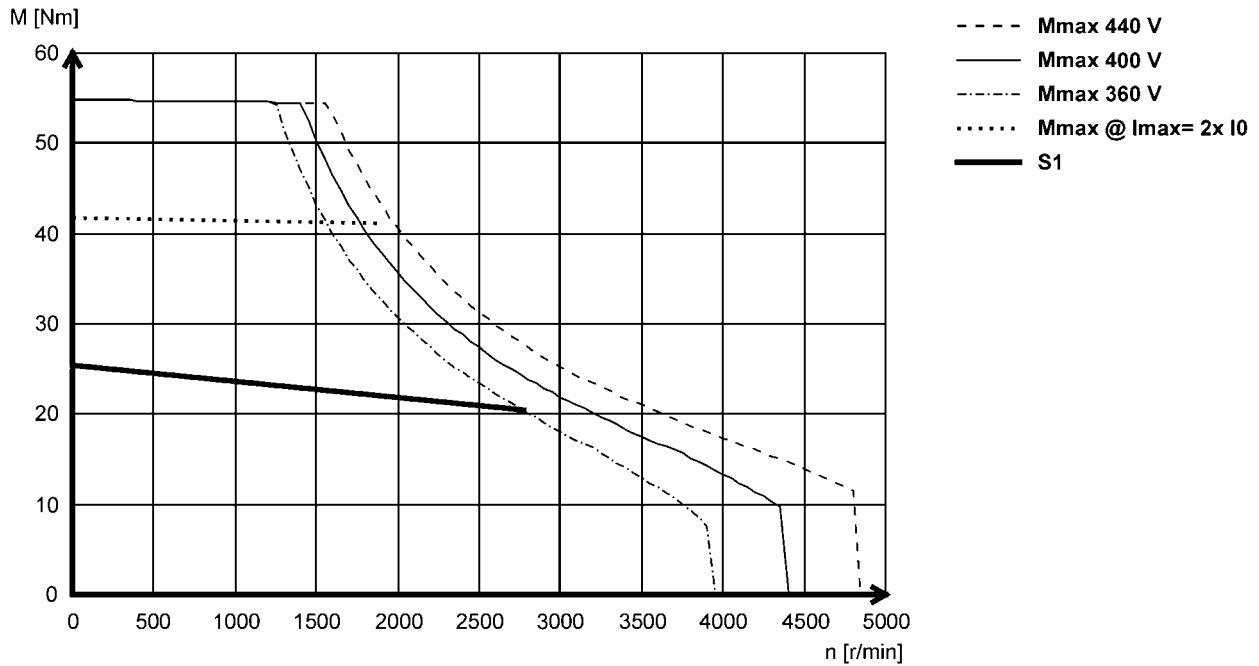

MCS14H32- (non-ventilated)

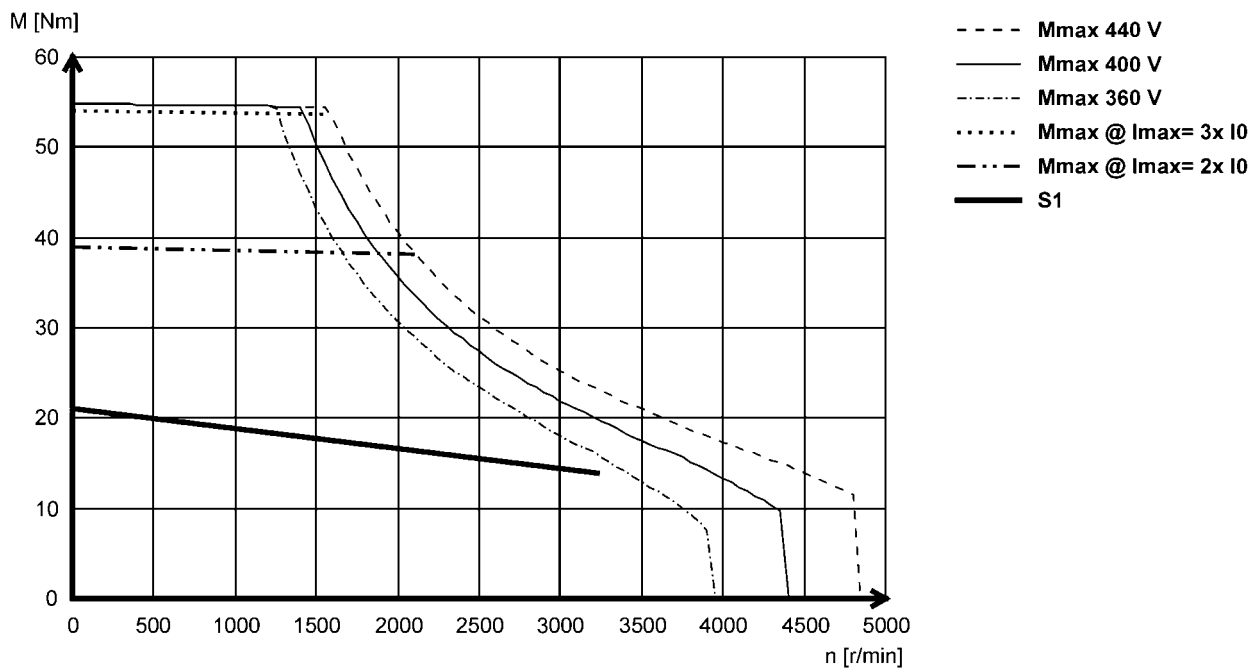

MCS synchronous servo motors

Technical data



Torque characteristics

- ▶ The data applies to a mains connection voltage of 3 x 400 V.
- ▶ You can find further torque characteristics at www.lenze.de/dsc.

MCS14L14- (forced ventilated)

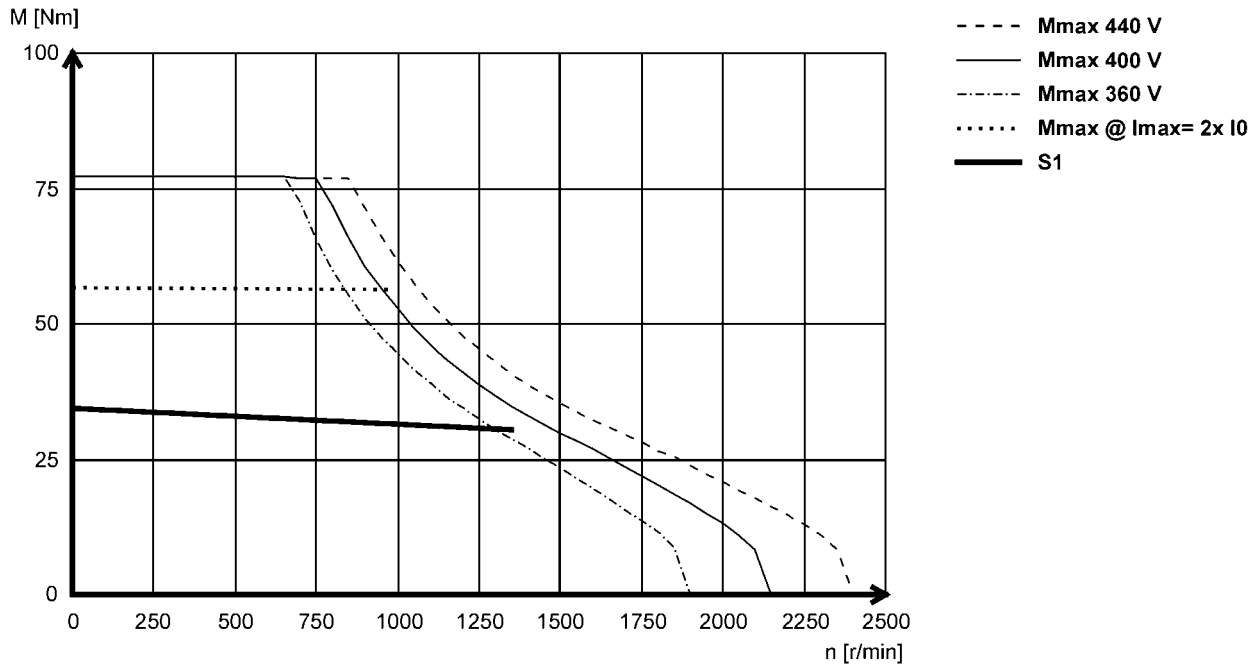

MCS14L15- (non-ventilated)

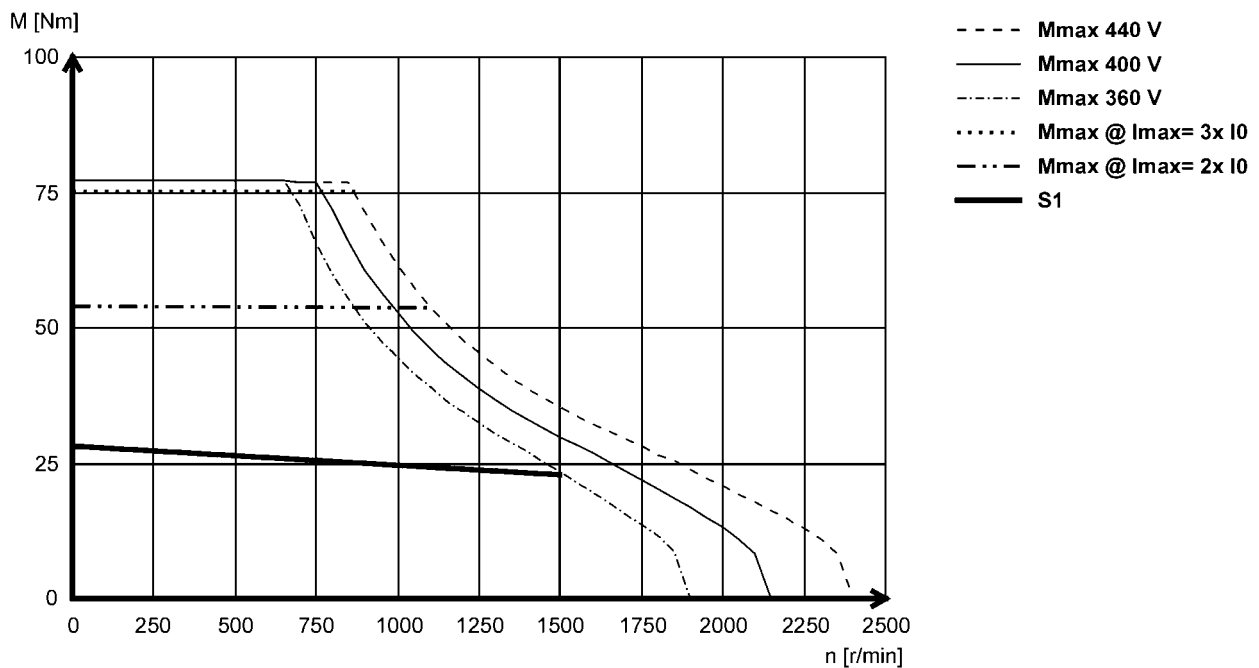

MCS synchronous servo motors

Technical data



Torque characteristics

- ▶ The data applies to a mains connection voltage of 3 x 400 V.
- ▶ You can find further torque characteristics at www.lenze.de/dsc.

MCS14L30- (forced ventilated)

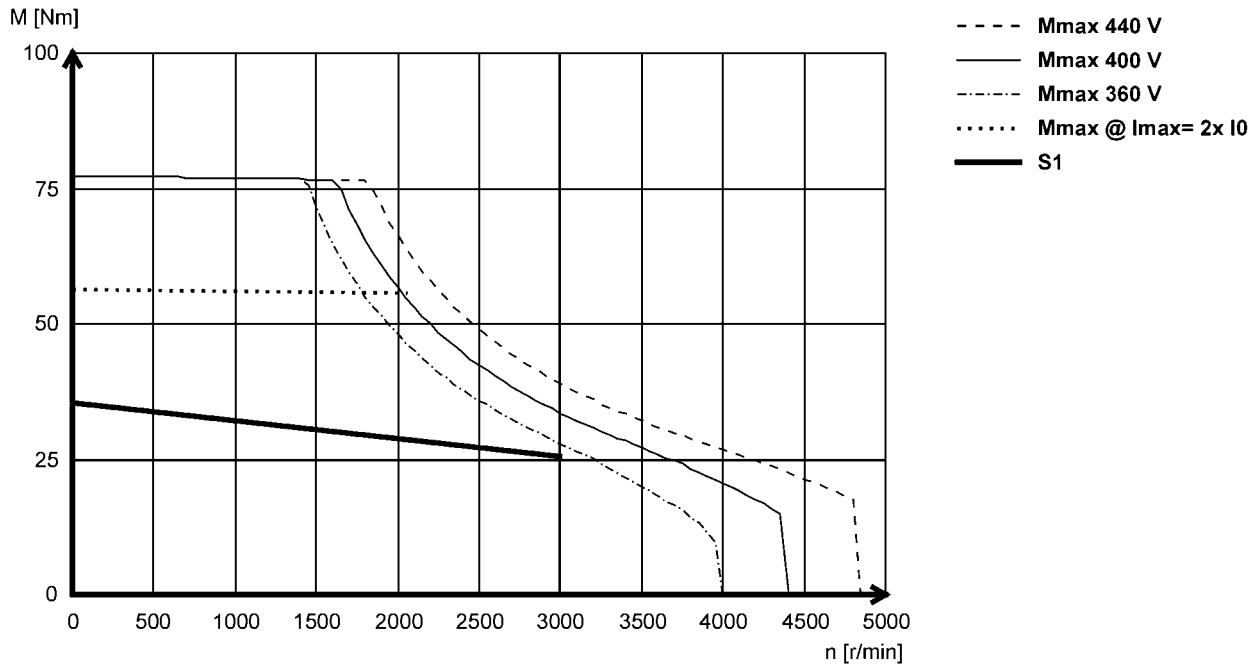

MCS14L32- (non-ventilated)

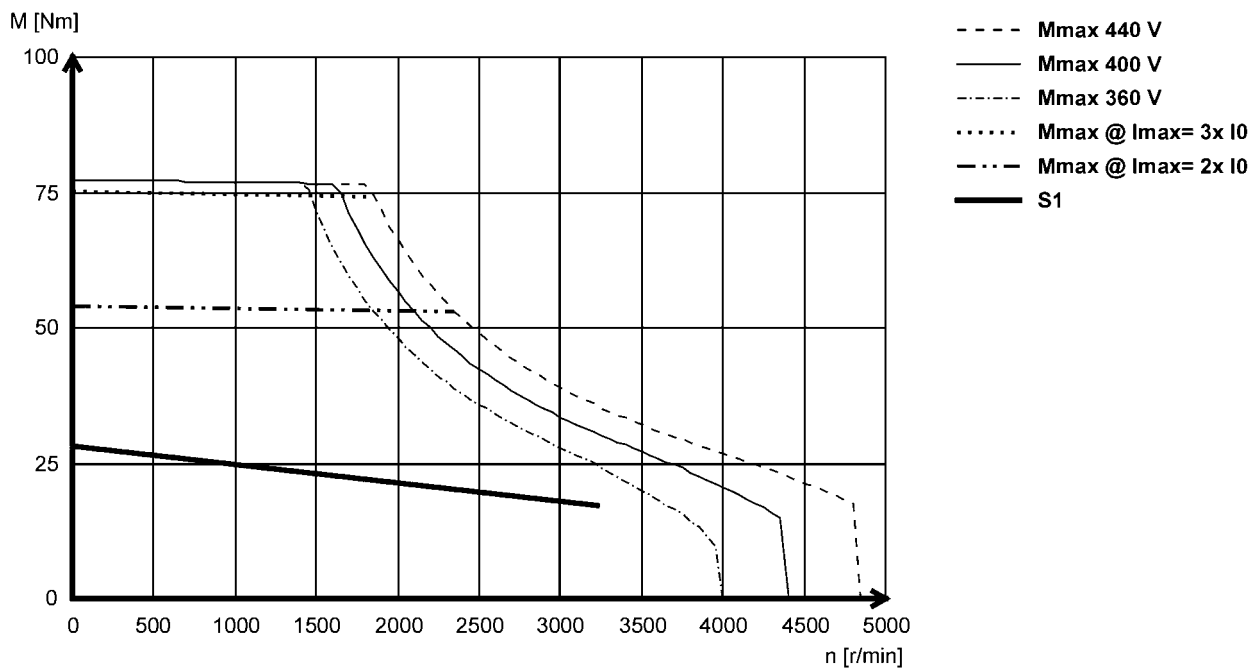

MCS synchronous servo motors

Technical data



Torque characteristics

- ▶ The data applies to a mains connection voltage of 3 x 400 V.
- ▶ You can find further torque characteristics at www.lenze.de/dsc.

MCS14P11- (forced ventilated)

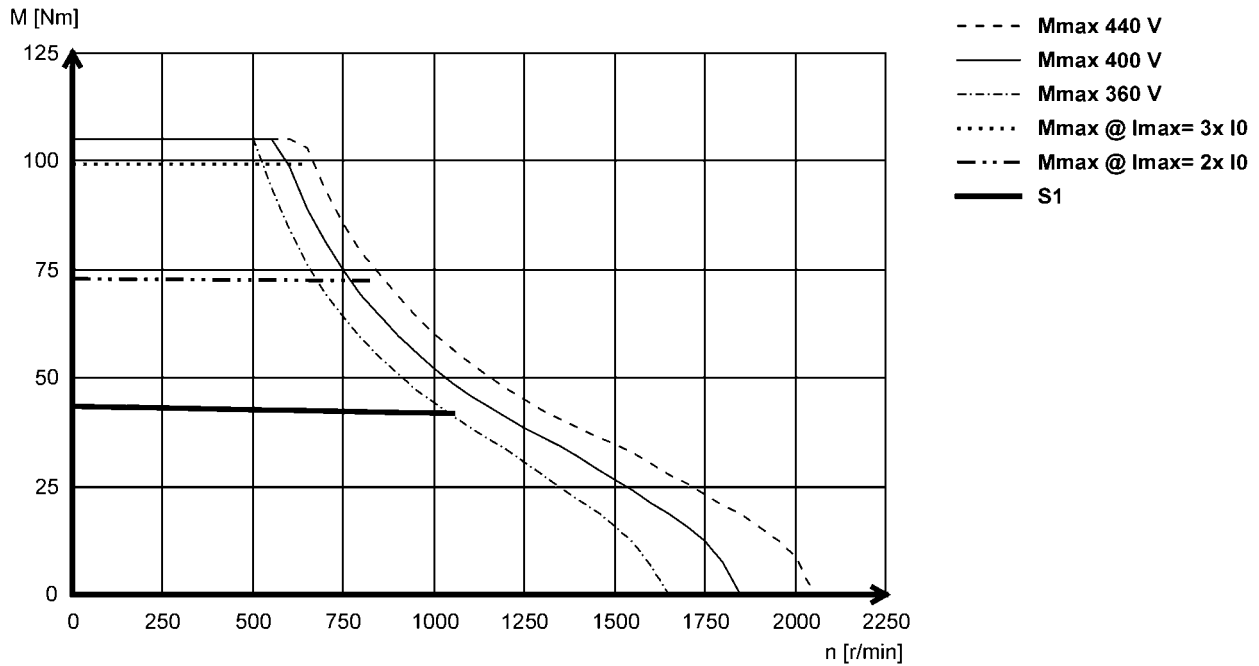

MCS14P14- (non-ventilated)

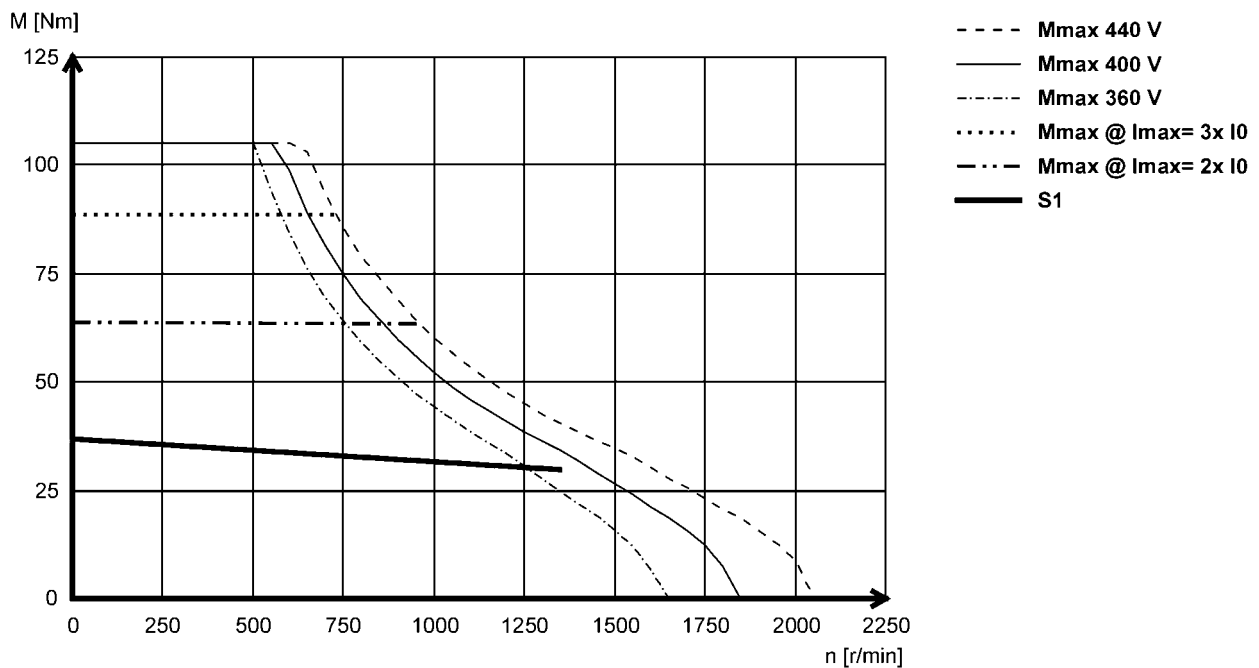

MCS synchronous servo motors

Technical data



Torque characteristics

- ▶ The data applies to a mains connection voltage of 3 x 400 V.
- ▶ You can find further torque characteristics at www.lenze.de/dsc.

MCS14P26- (forced ventilated)

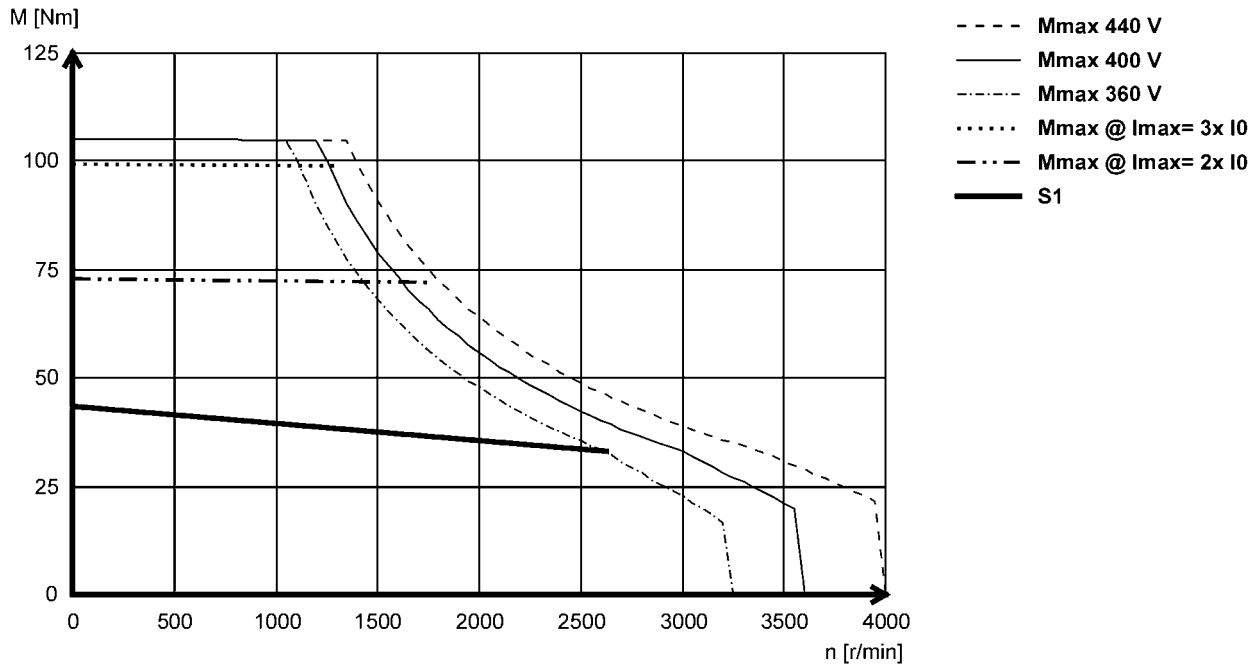

MCS14P32- (non-ventilated)

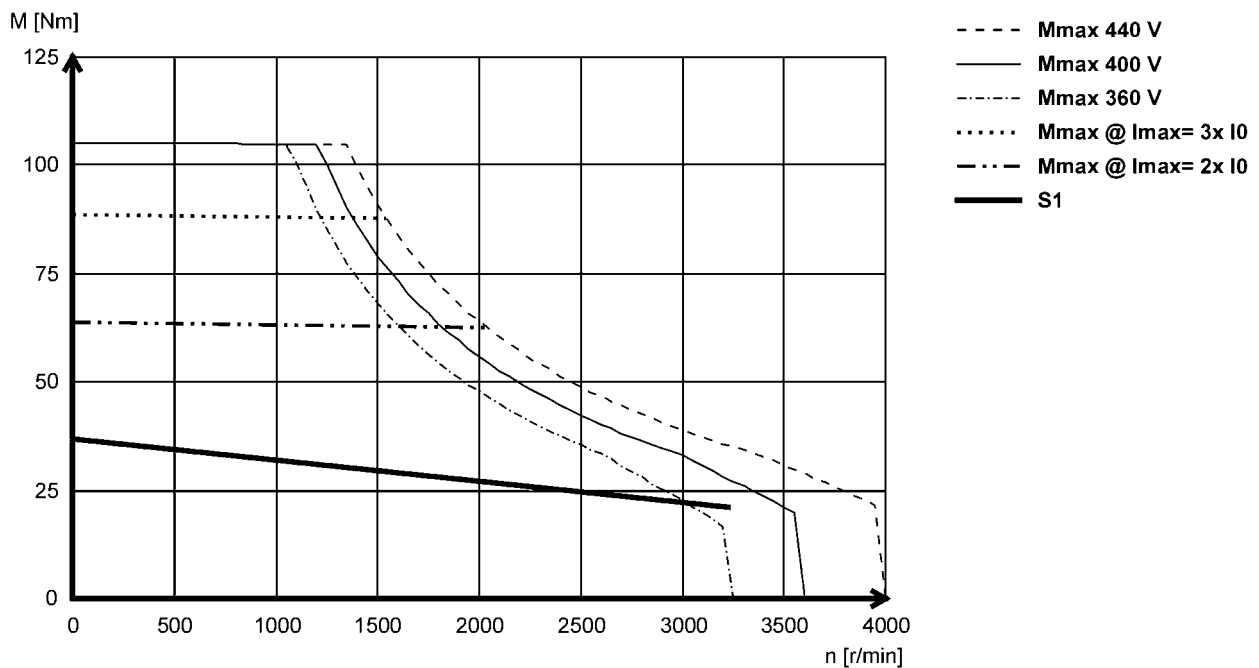

MCS synchronous servo motors

Technical data



Torque characteristics

- ▶ The data applies to a mains connection voltage of 3 x 400 V.
- ▶ You can find further torque characteristics at www.lenze.de/dsc.

MCS19F12- (forced ventilated)

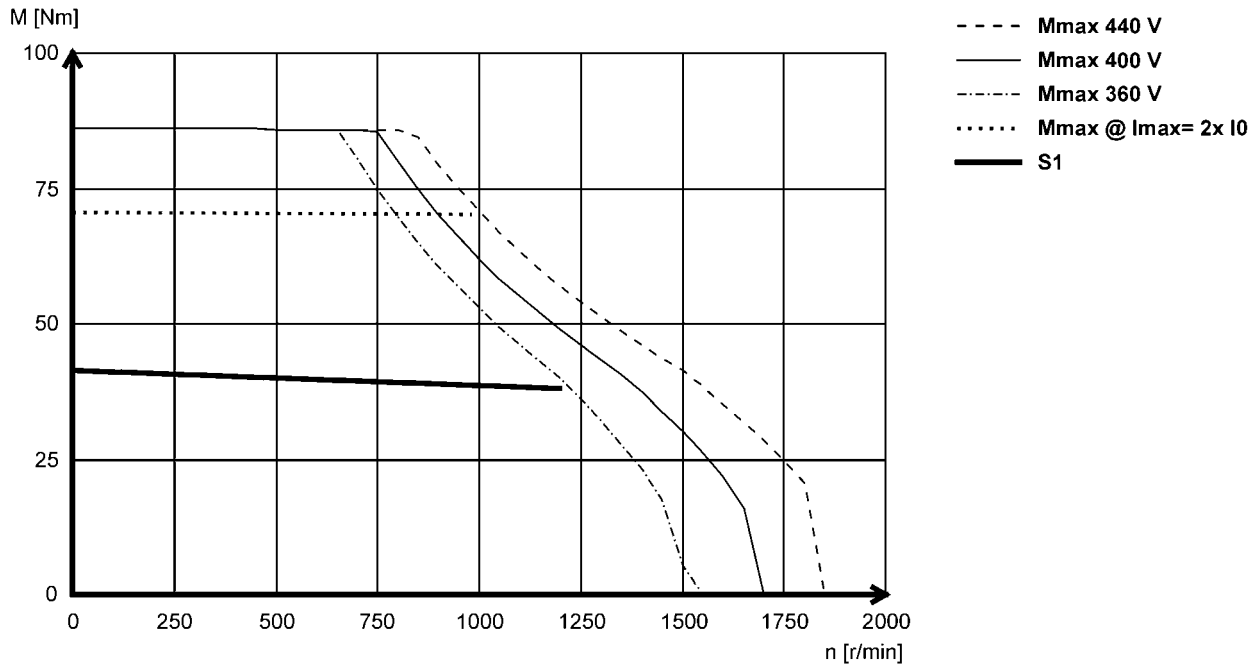

MCS19F14- (non-ventilated)

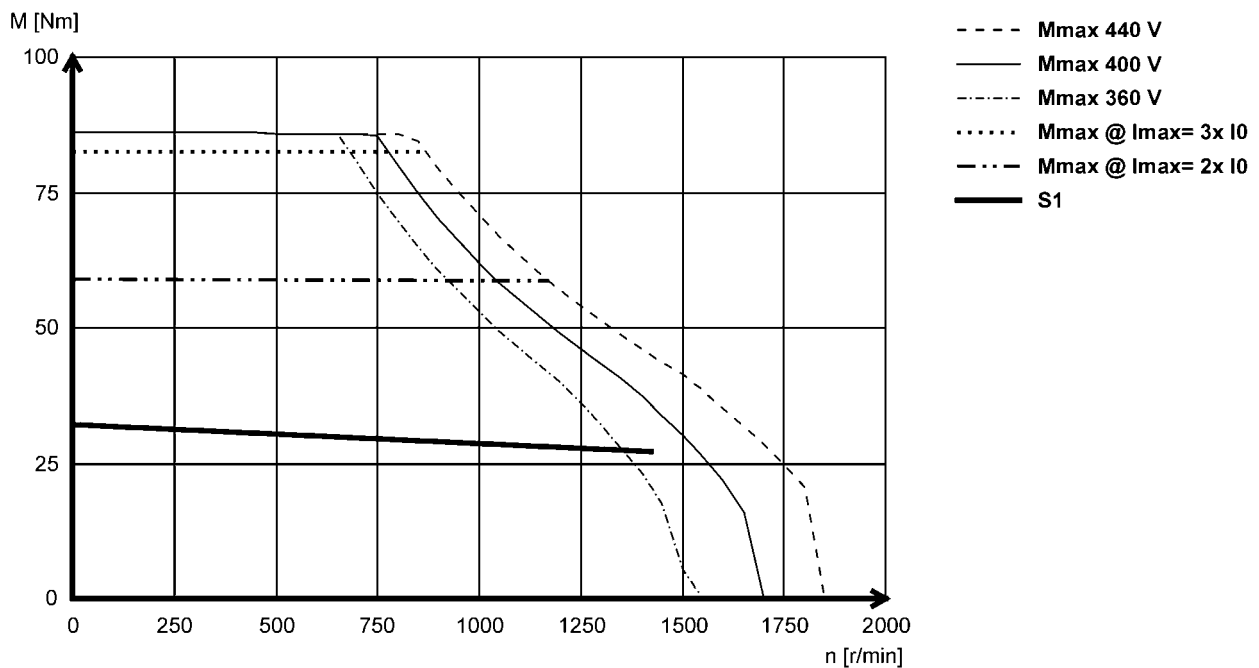

MCS synchronous servo motors

Technical data



Torque characteristics

- ▶ The data applies to a mains connection voltage of 3 x 400 V.
- ▶ You can find further torque characteristics at www.lenze.de/dsc.

MCS19F29- (forced ventilated)

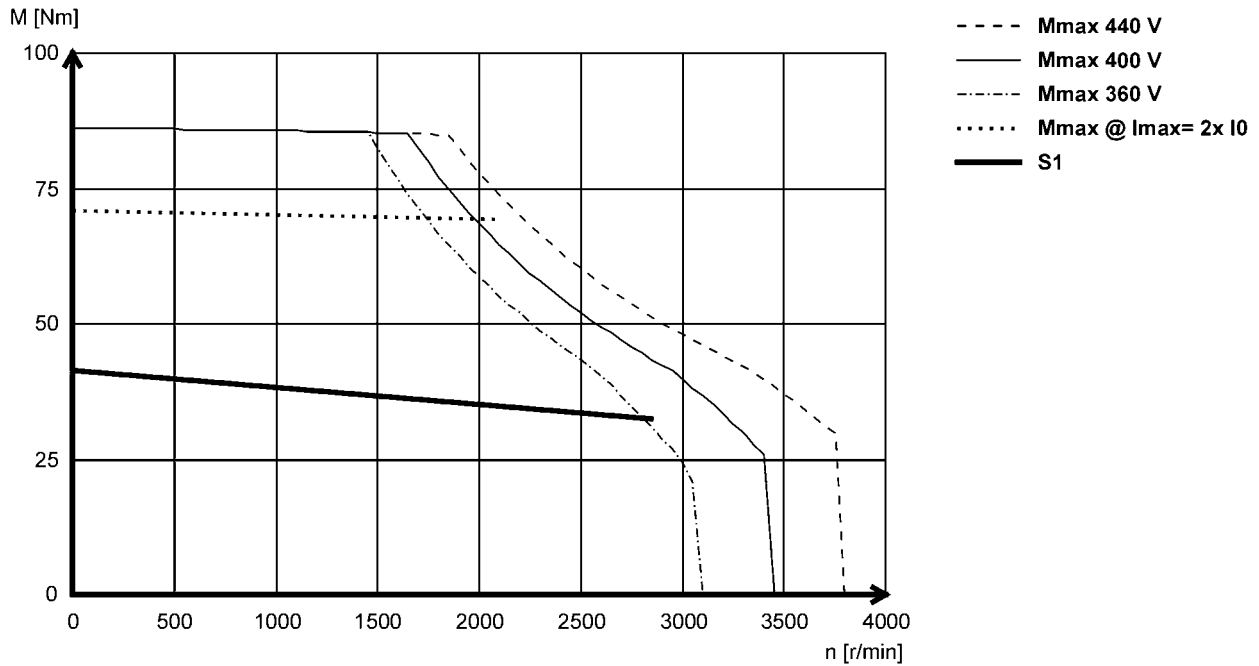

MCS19F30- (non-ventilated)

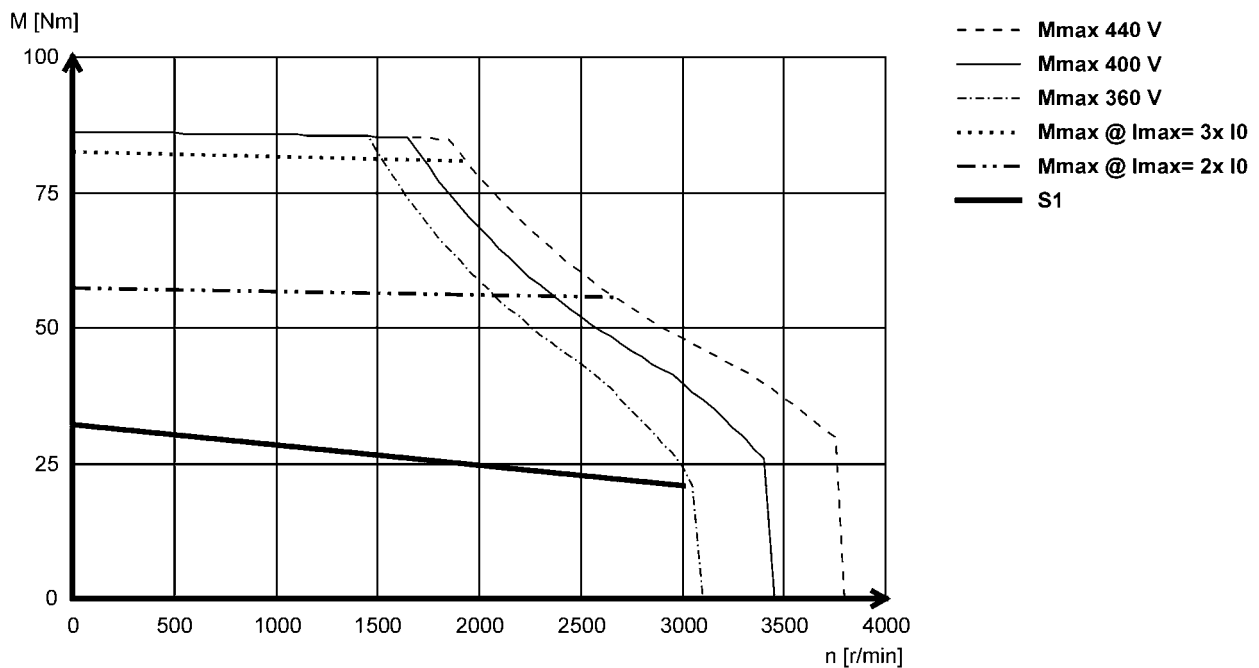

6.11

MCS synchronous servo motors

Technical data



Torque characteristics

- ▶ The data applies to a mains connection voltage of 3 x 400 V.
- ▶ You can find further torque characteristics at www.lenze.de/dsc.

MCS19J12- (forced ventilated)

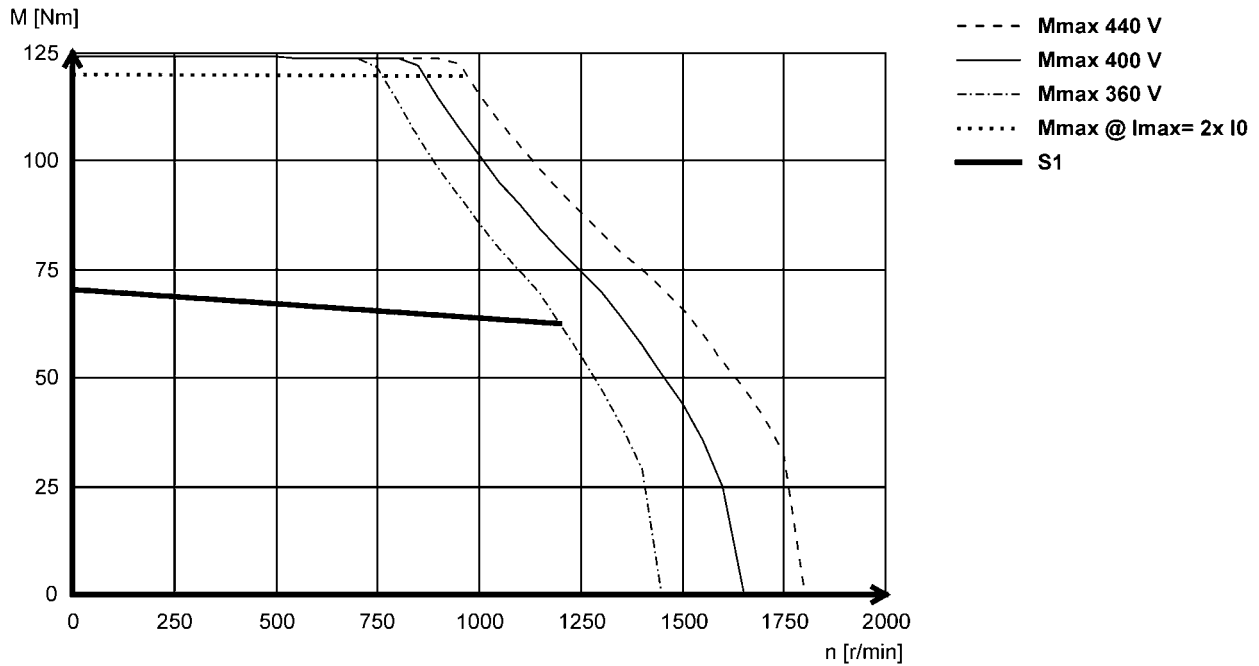

MCS19J14- (non-ventilated)

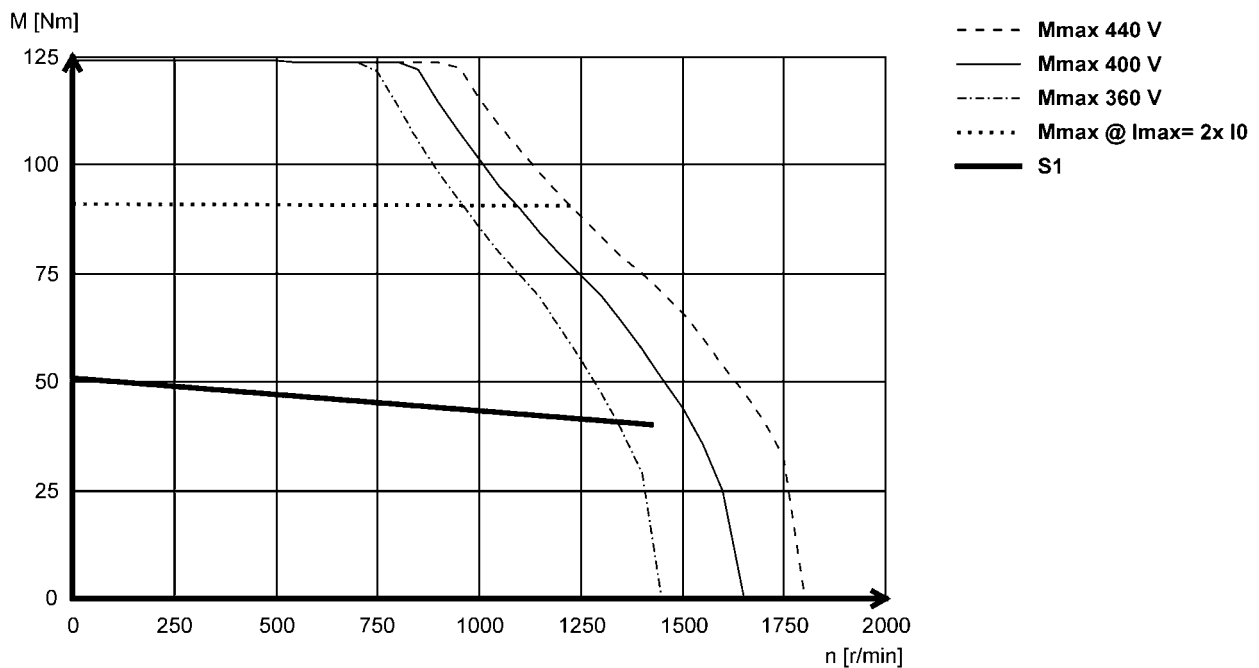

6.11

MCS synchronous servo motors

Technical data



Torque characteristics

- ▶ The data applies to a mains connection voltage of 3 x 400 V.
- ▶ You can find further torque characteristics at www.lenze.de/dsc.

MCS19J29- (forced ventilated)

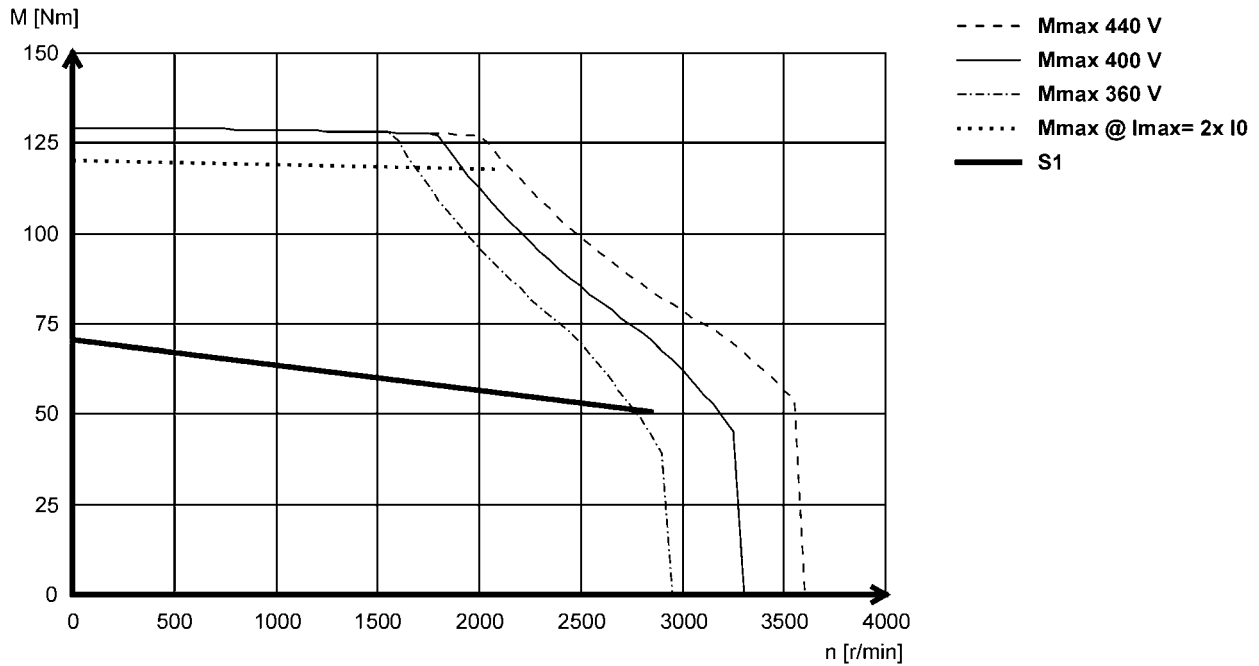

MCS19J30- (non-ventilated)

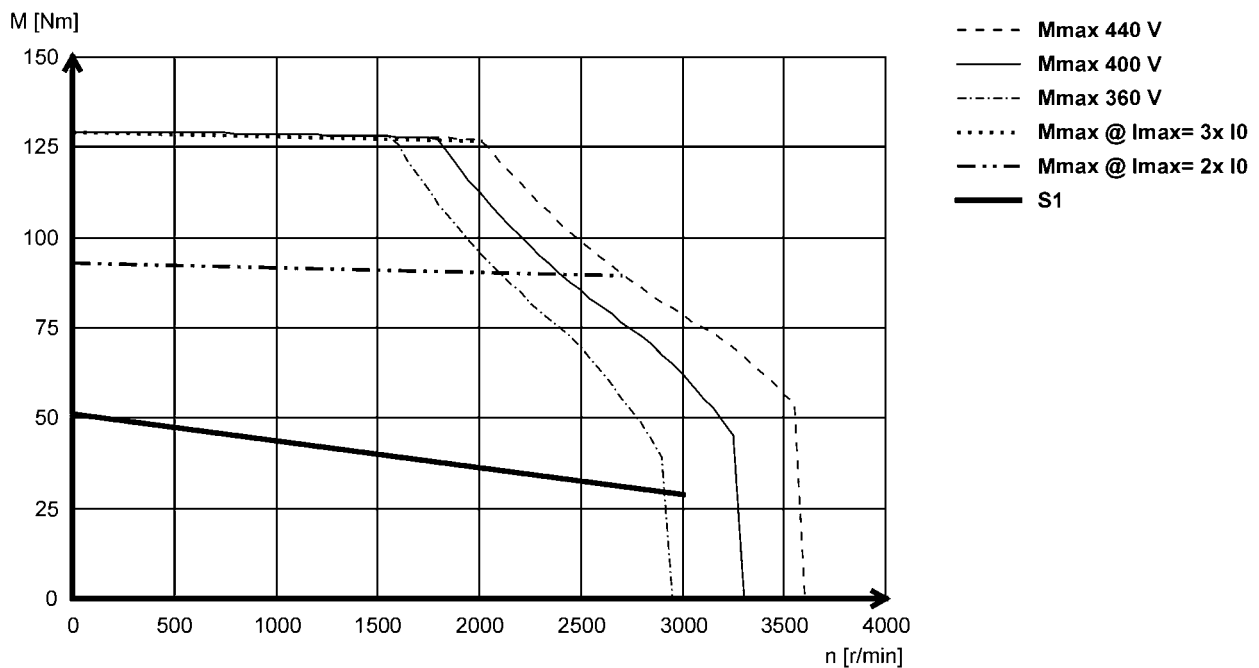

MCS synchronous servo motors

Technical data



Torque characteristics

- ▶ The data applies to a mains connection voltage of 3 x 400 V.
- ▶ You can find further torque characteristics at www.lenze.de/dsc.

MCS19P12 (forced ventilated)

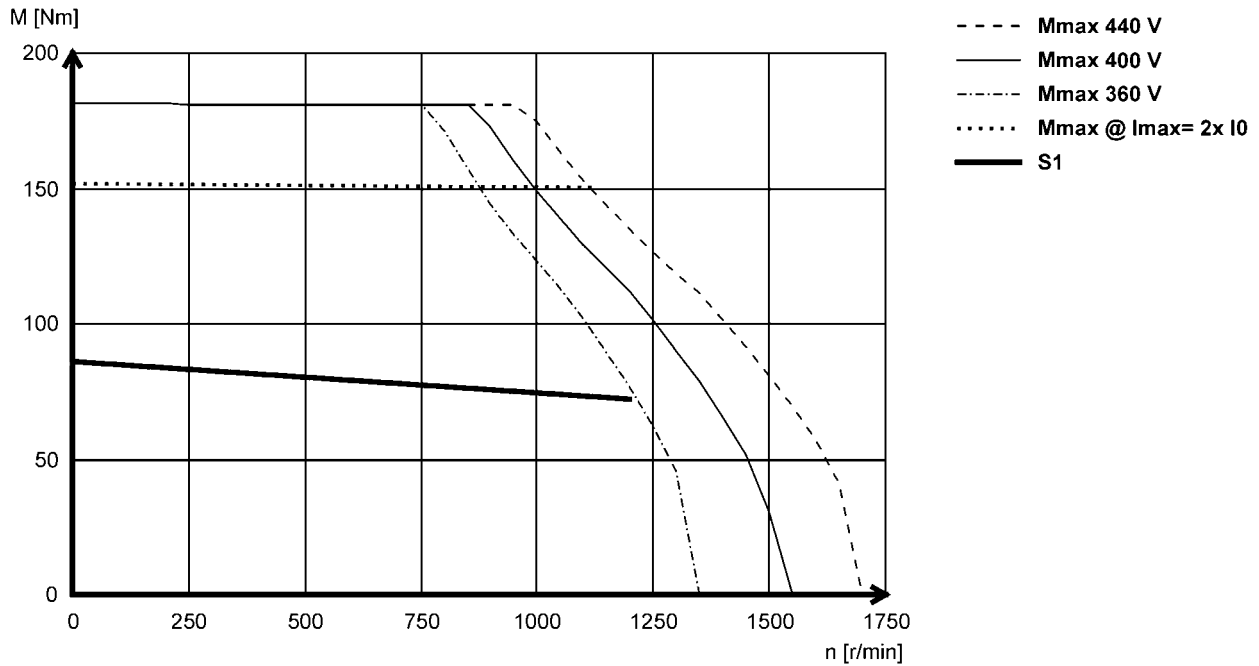

MCS19P14- (non-ventilated)

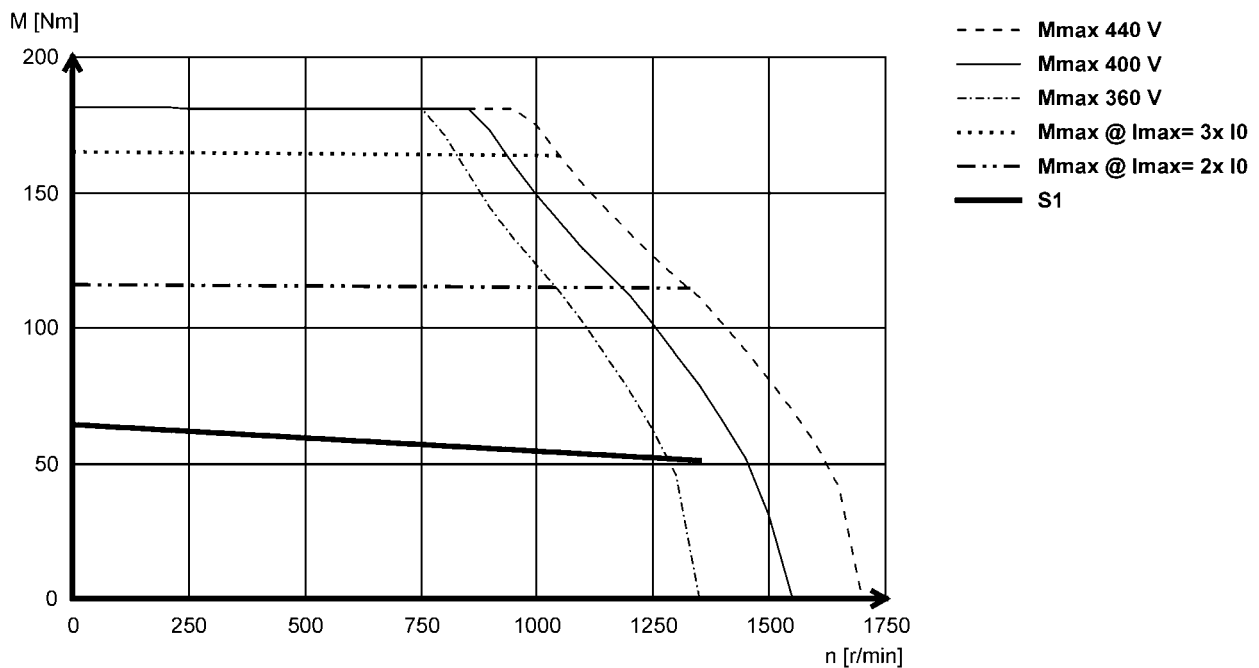

6.11

MCS synchronous servo motors

Technical data



Torque characteristics

- ▶ The data applies to a mains connection voltage of 3 x 400 V.
- ▶ You can find further torque characteristics at www.lenze.de/dsc.

MCS19P29- (forced ventilated)

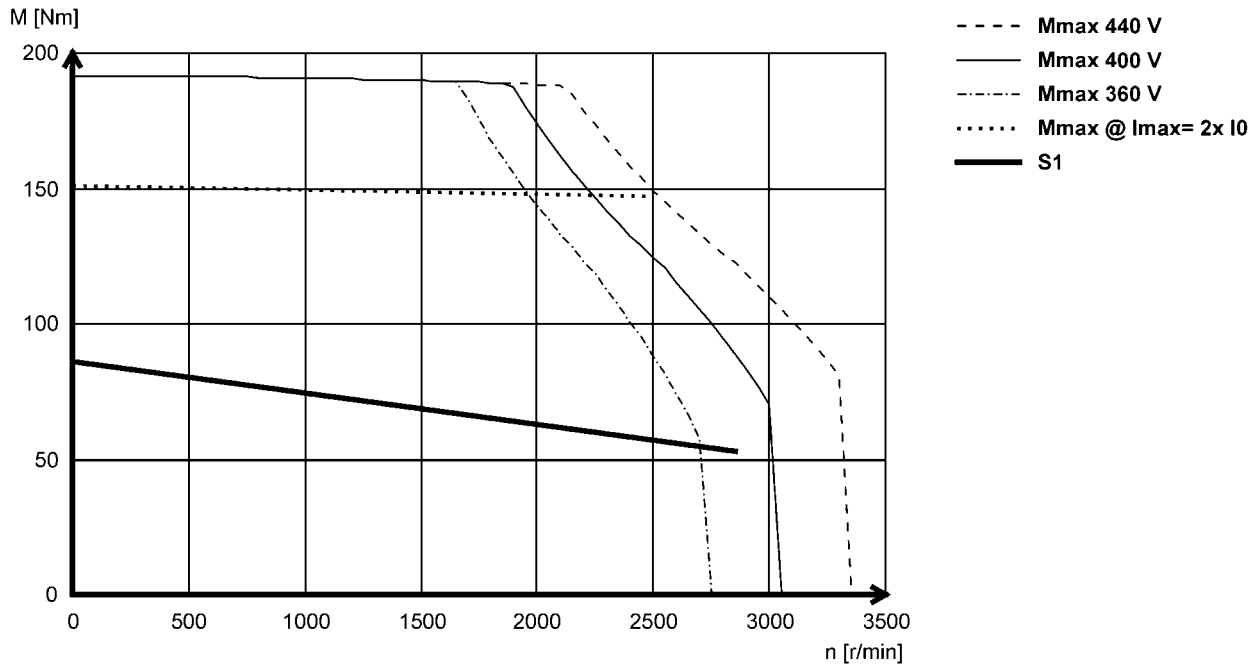

MCS19P30- (non-ventilated)

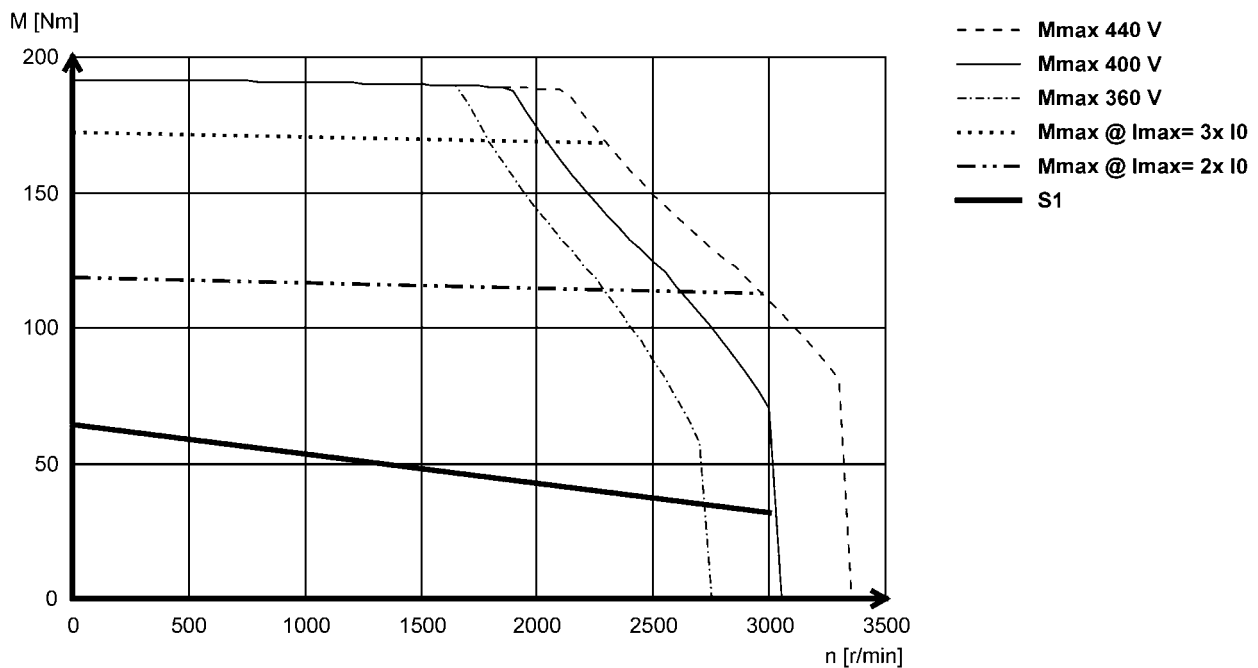

6.11

MCS synchronous servo motors

Technical data



Torque characteristics

- ▶ The data applies to a mains connection voltage of 3 x 230 V.
- ▶ You can find further torque characteristics at www.lenze.de/dsc.

MCS06C41L (non-ventilated)

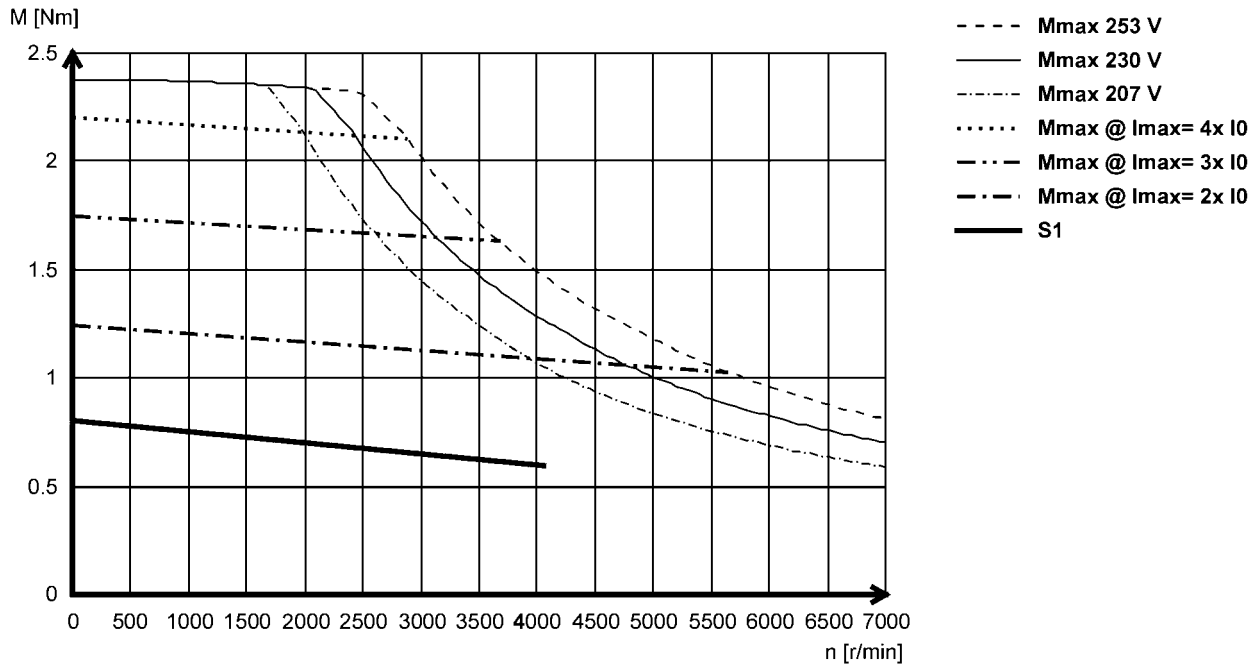

MCS06C60L (non-ventilated)

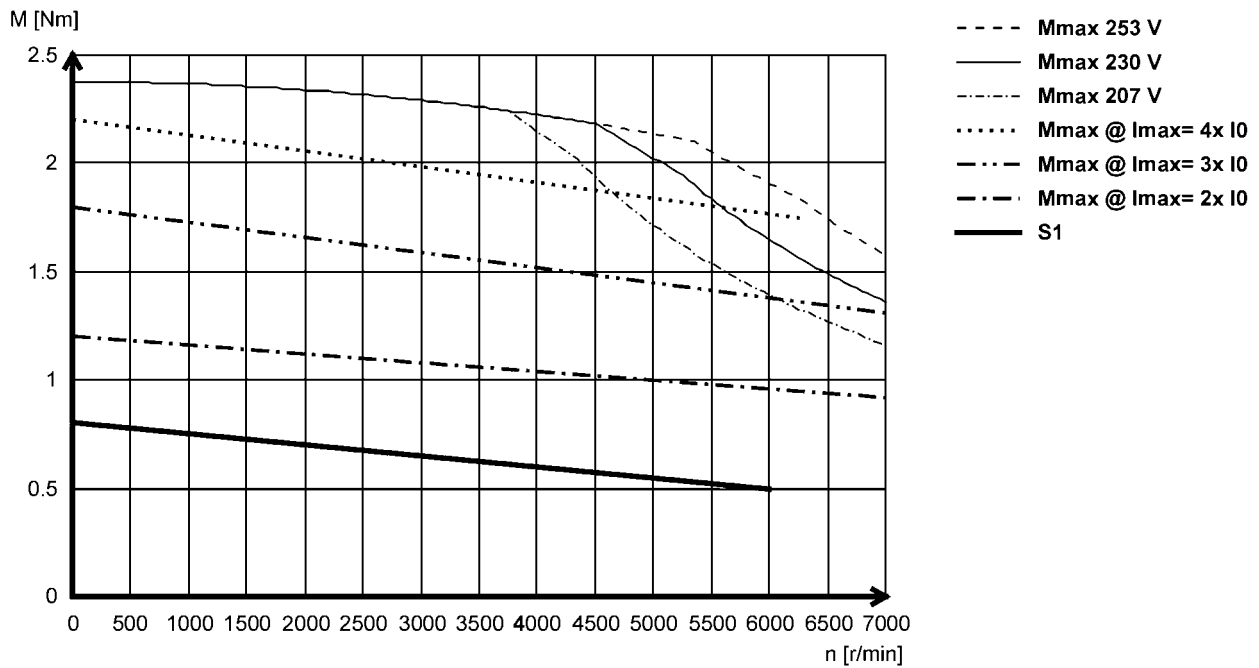

MCS synchronous servo motors

Technical data



Torque characteristics

- ▶ The data applies to a mains connection voltage of 3 x 230 V.
- ▶ You can find further torque characteristics at www.lenze.de/dsc.

MCS06F41L (non-ventilated)

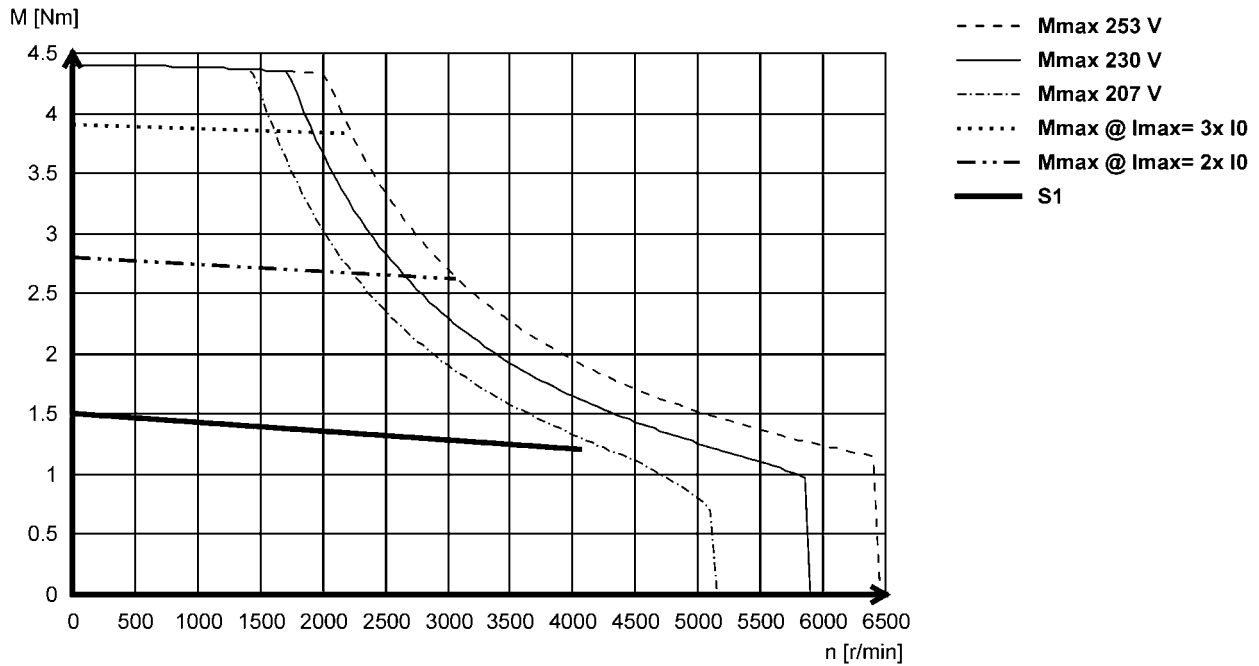

MCS06F60L (non-ventilated)

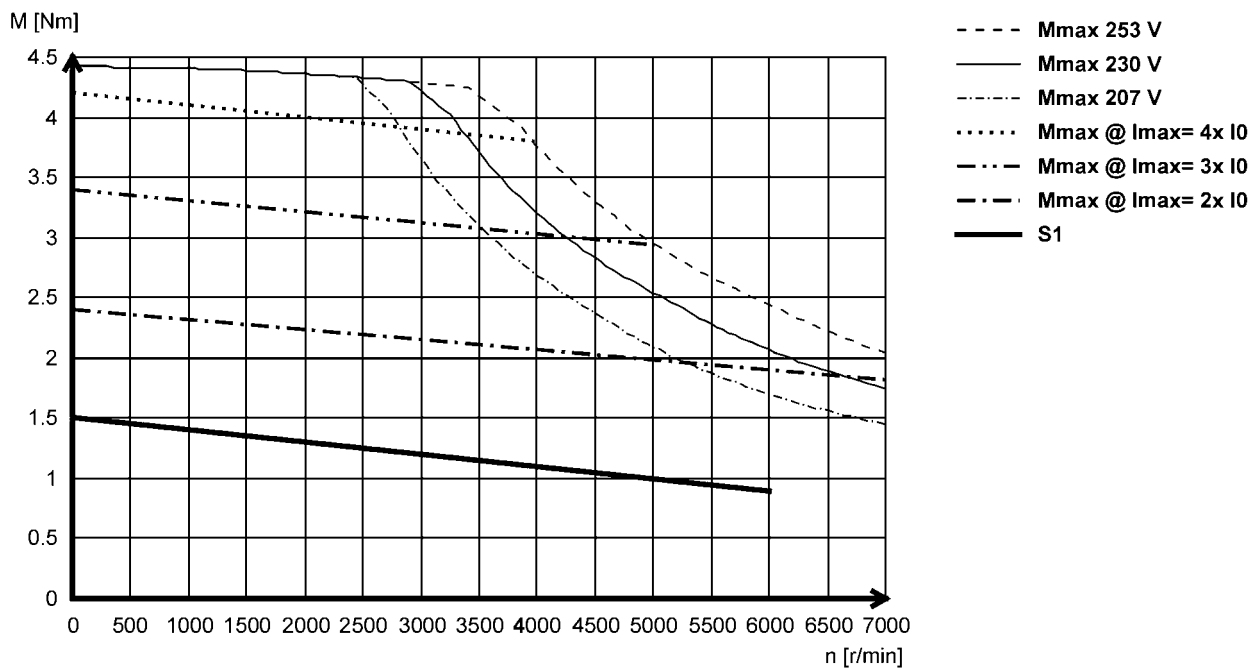

MCS synchronous servo motors

Technical data



Torque characteristics

- ▶ The data applies to a mains connection voltage of 3 x 230 V.
- ▶ You can find further torque characteristics at www.lenze.de/dsc.

MCS06I41L (non-ventilated)

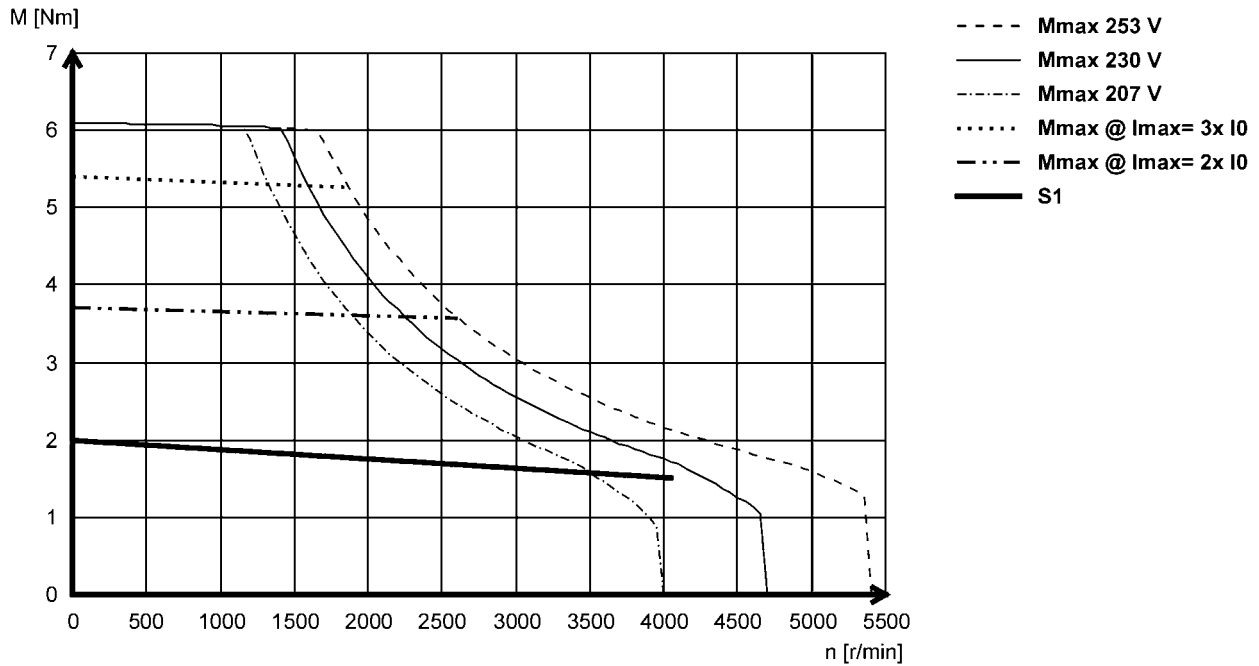

MCS06I60L (non-ventilated)

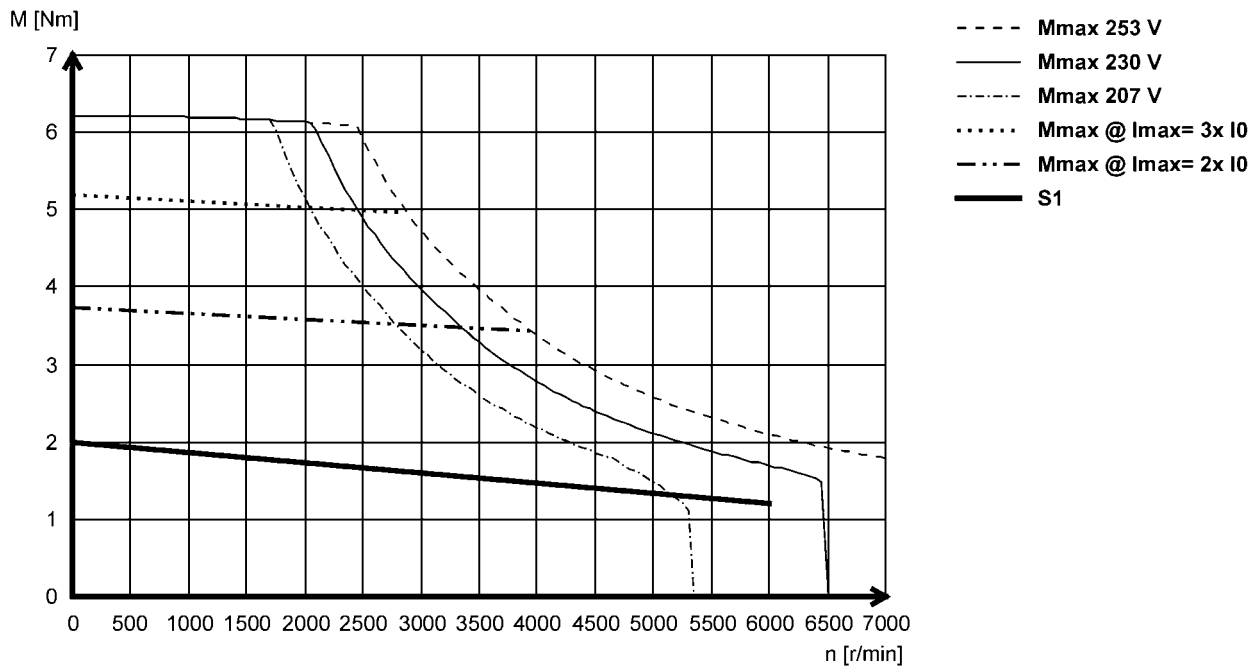

MCS synchronous servo motors

Technical data



Torque characteristics

- ▶ The data applies to a mains connection voltage of 3 x 230 V.
- ▶ You can find further torque characteristics at www.lenze.de/dsc.

MCS09D41L (non-ventilated)

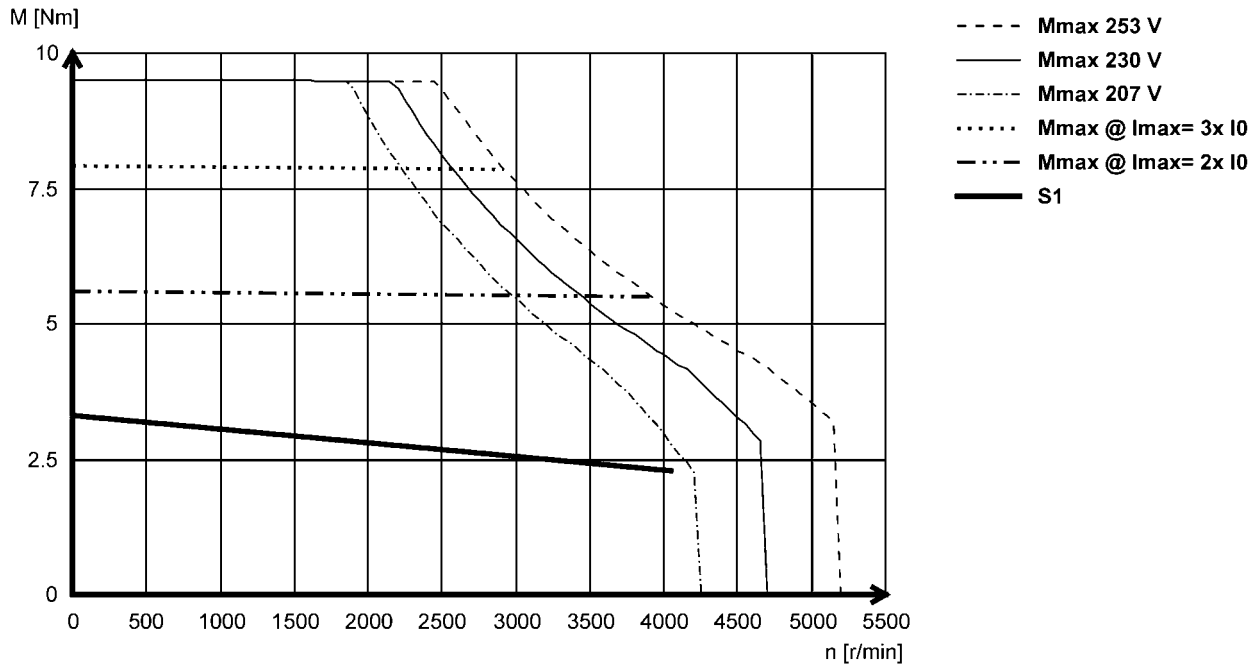

MCS09D60L (non-ventilated)

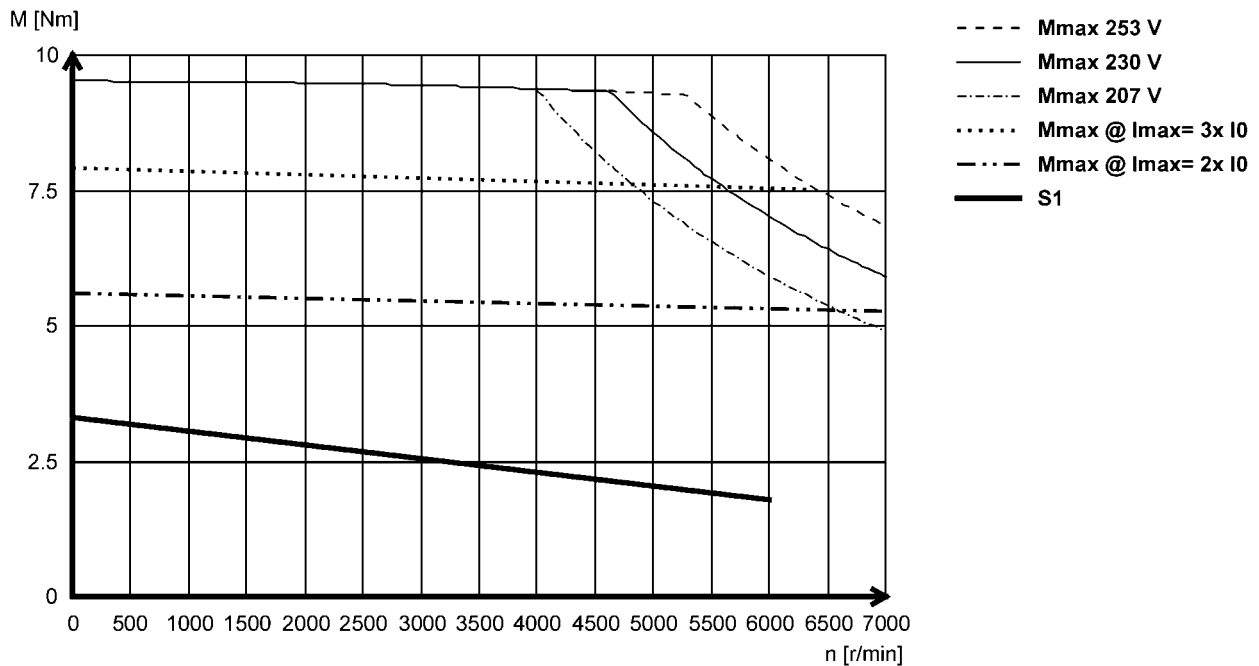

MCS synchronous servo motors

Technical data



Torque characteristics

- ▶ The data applies to a mains connection voltage of 3 x 230 V.
- ▶ You can find further torque characteristics at www.lenze.de/dsc.

MCS09F38L (non-ventilated)

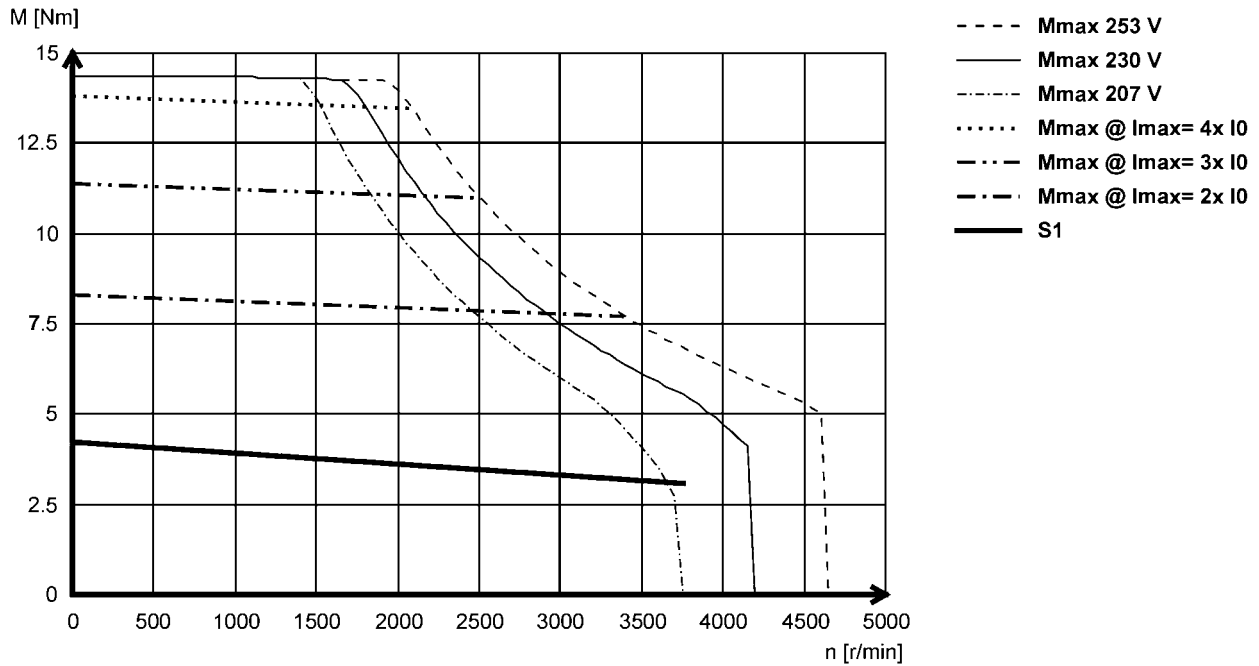

MCS09F60L (non-ventilated)

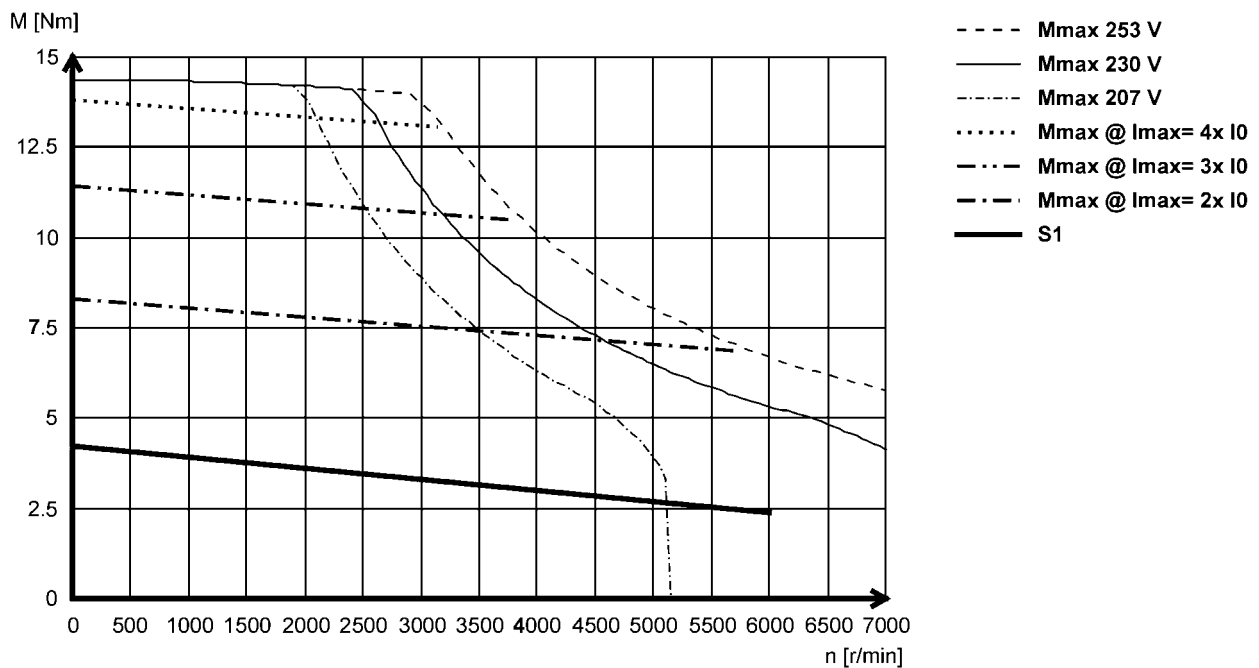

6.11

MCS synchronous servo motors

Technical data



Torque characteristics

- ▶ The data applies to a mains connection voltage of 3 x 230 V.
- ▶ You can find further torque characteristics at www.lenze.de/dsc.

MCS09H41L (non-ventilated)

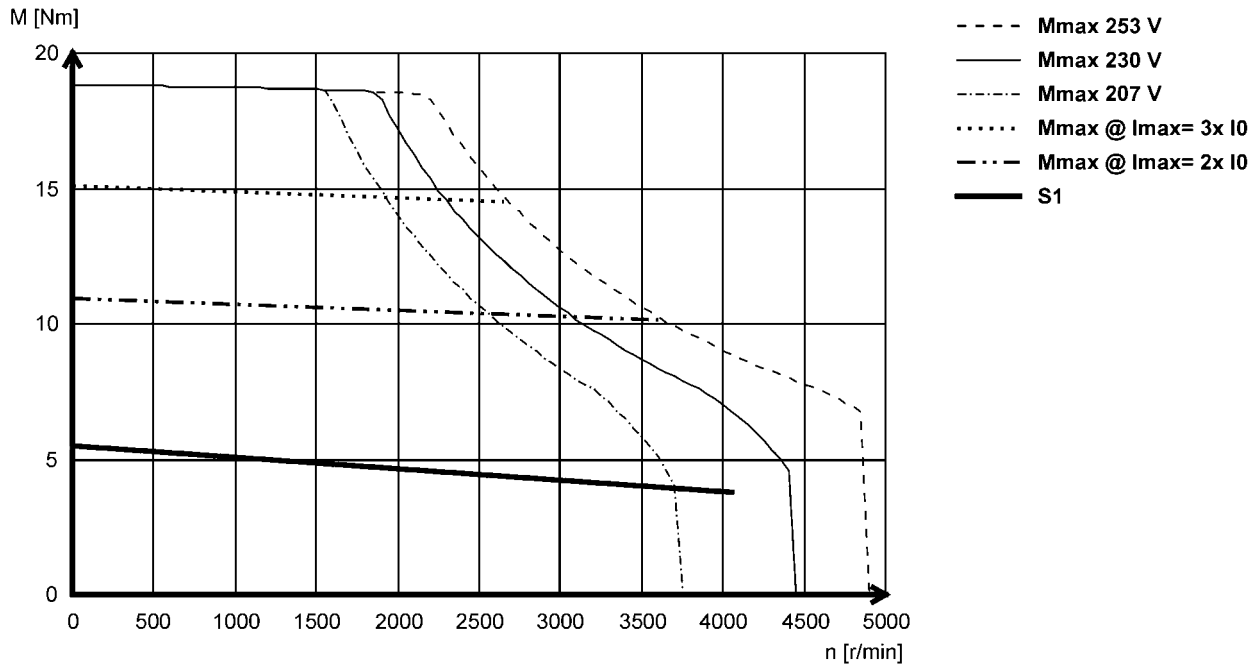

MCS09H60L (non-ventilated)

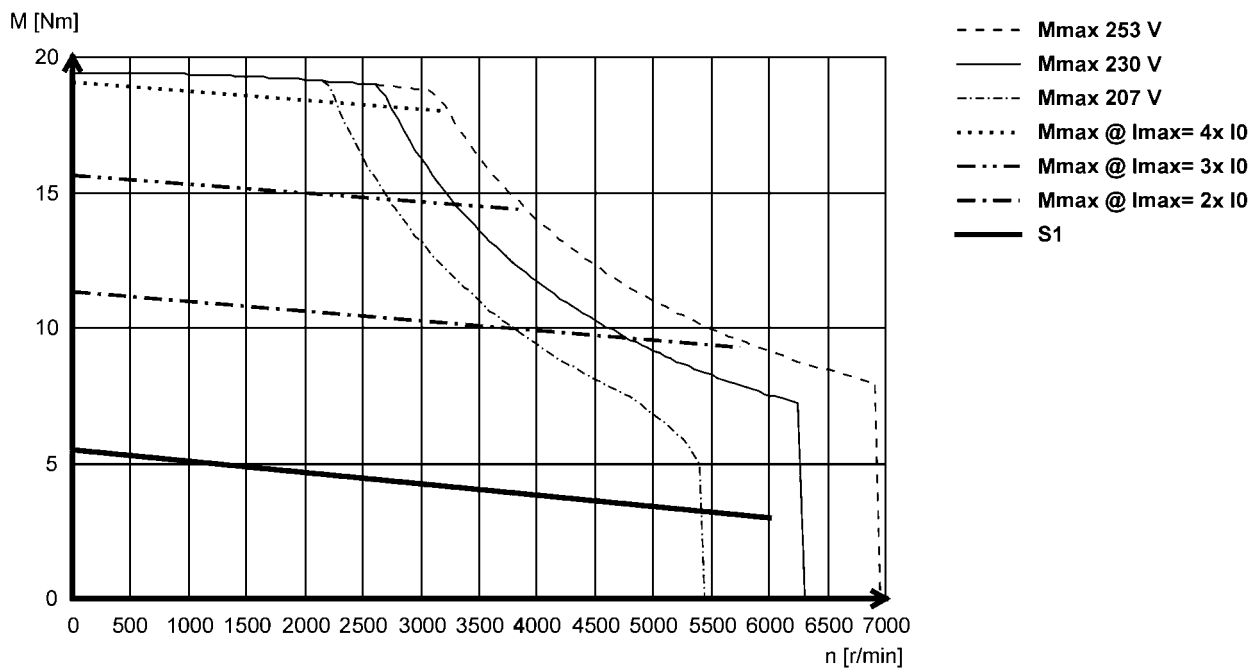

MCS synchronous servo motors

Technical data



Torque characteristics

- ▶ The data applies to a mains connection voltage of 3 x 230 V.
- ▶ You can find further torque characteristics at www.lenze.de/dsc.

MCS09L41L (non-ventilated)

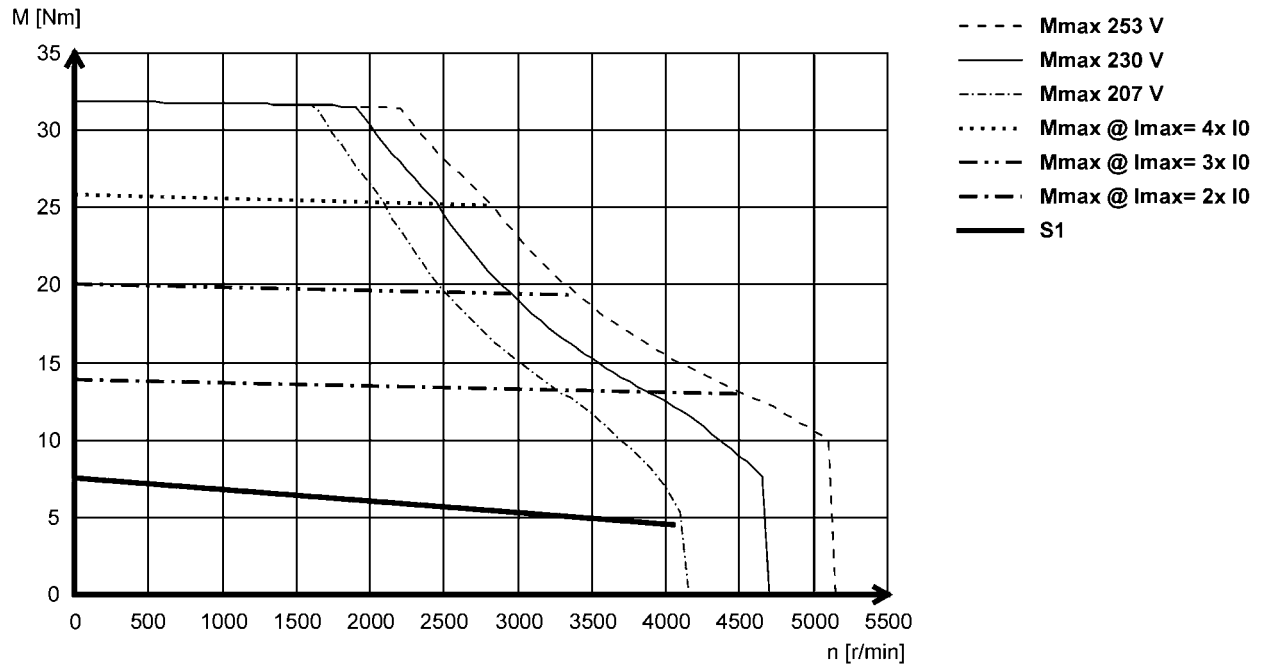

MCS synchronous servo motors

Technical data



Torque characteristics

- ▶ The data applies to a mains connection voltage of 3 x 230 V.
- ▶ You can find further torque characteristics at www.lenze.de/dsc.

MCS12D20L (non-ventilated)

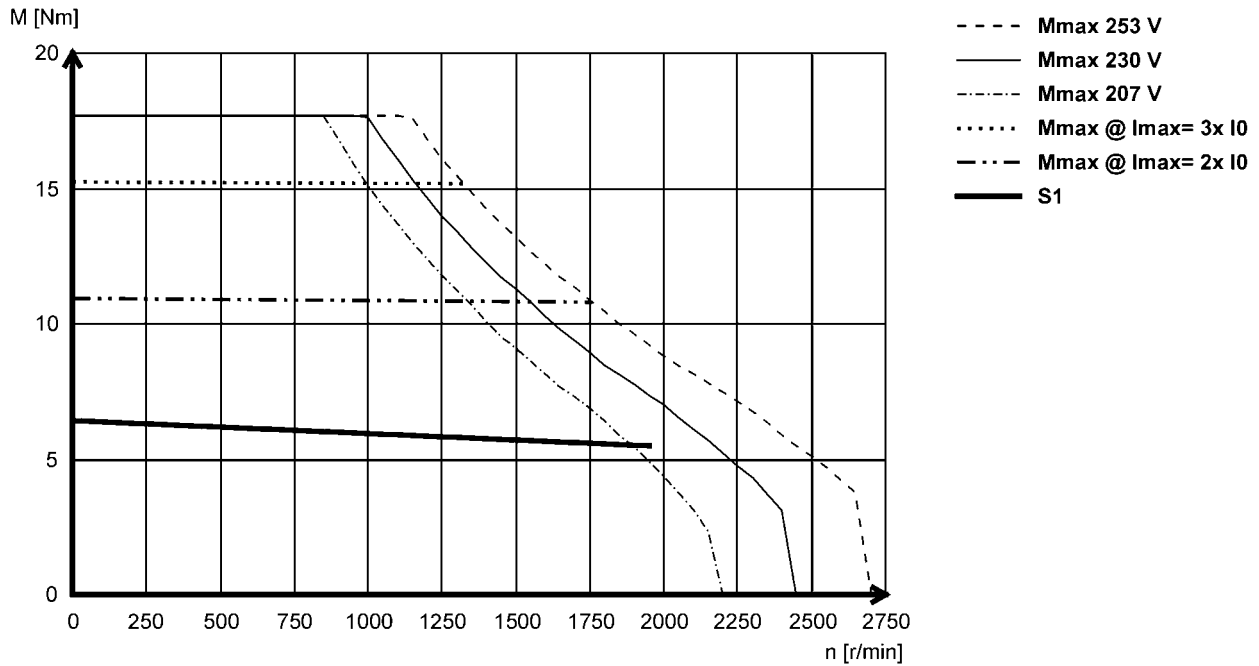

MCS12D41L (non-ventilated)

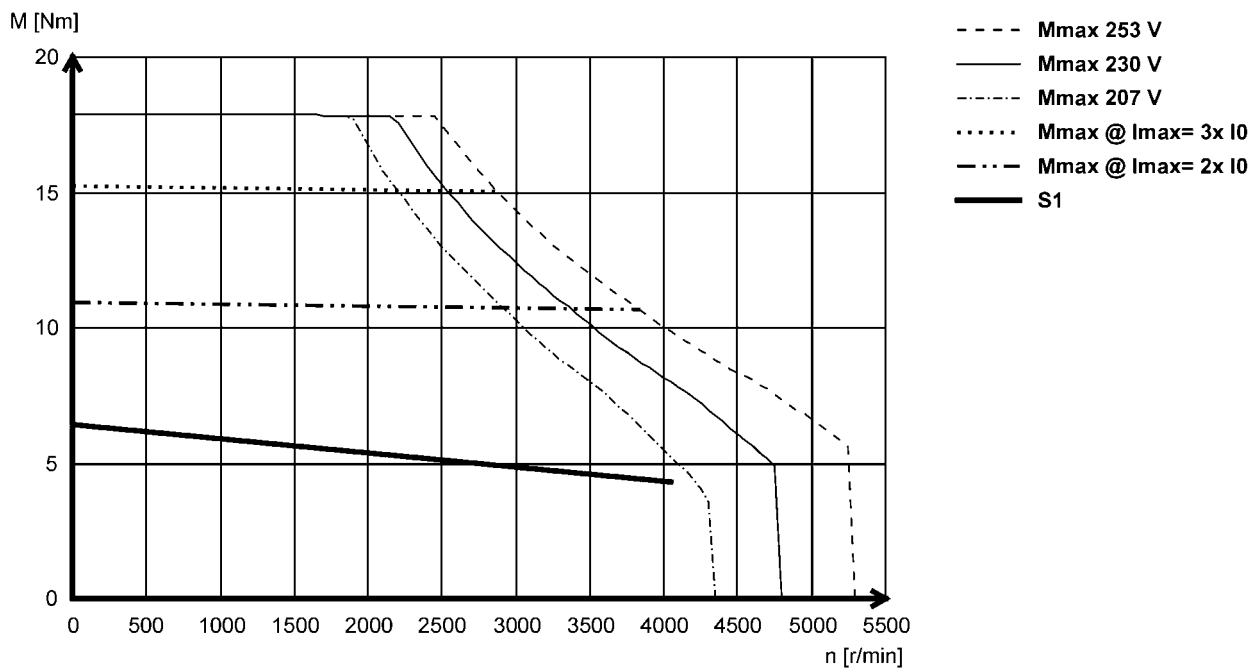

MCS synchronous servo motors

Technical data



Torque characteristics

- ▶ The data applies to a mains connection voltage of 3 x 230 V.
- ▶ You can find further torque characteristics at www.lenze.de/dsc.

MCS12H15L (non-ventilated)

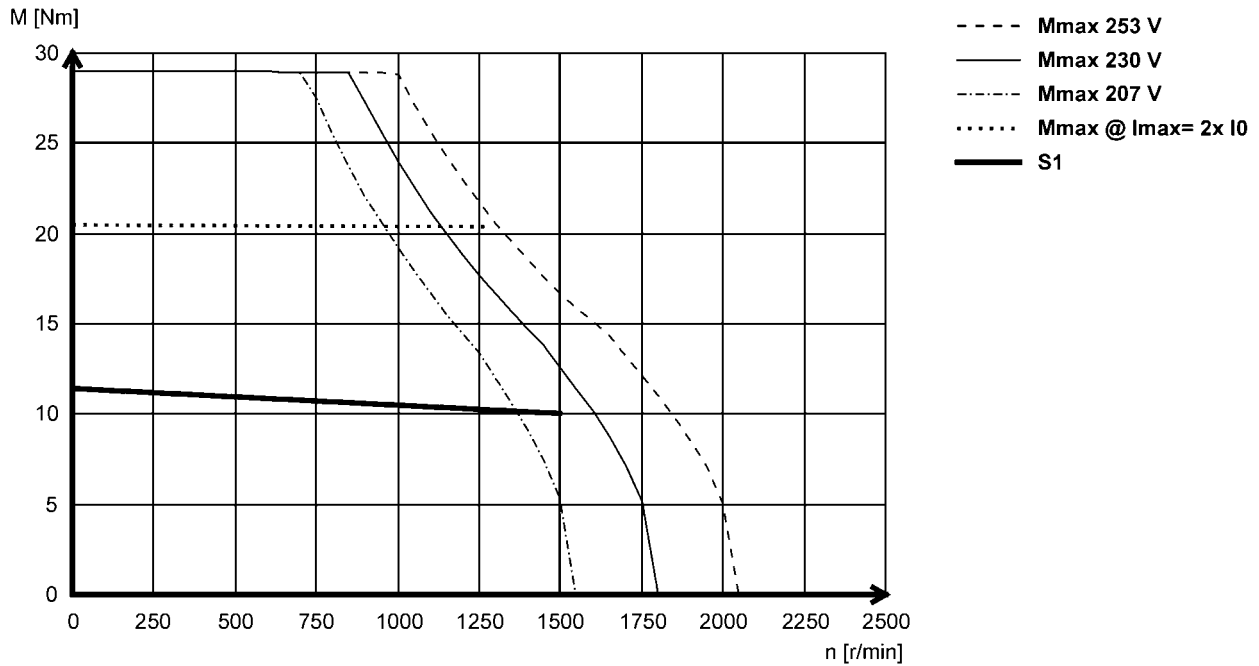

MCS12H30L- (non-ventilated)

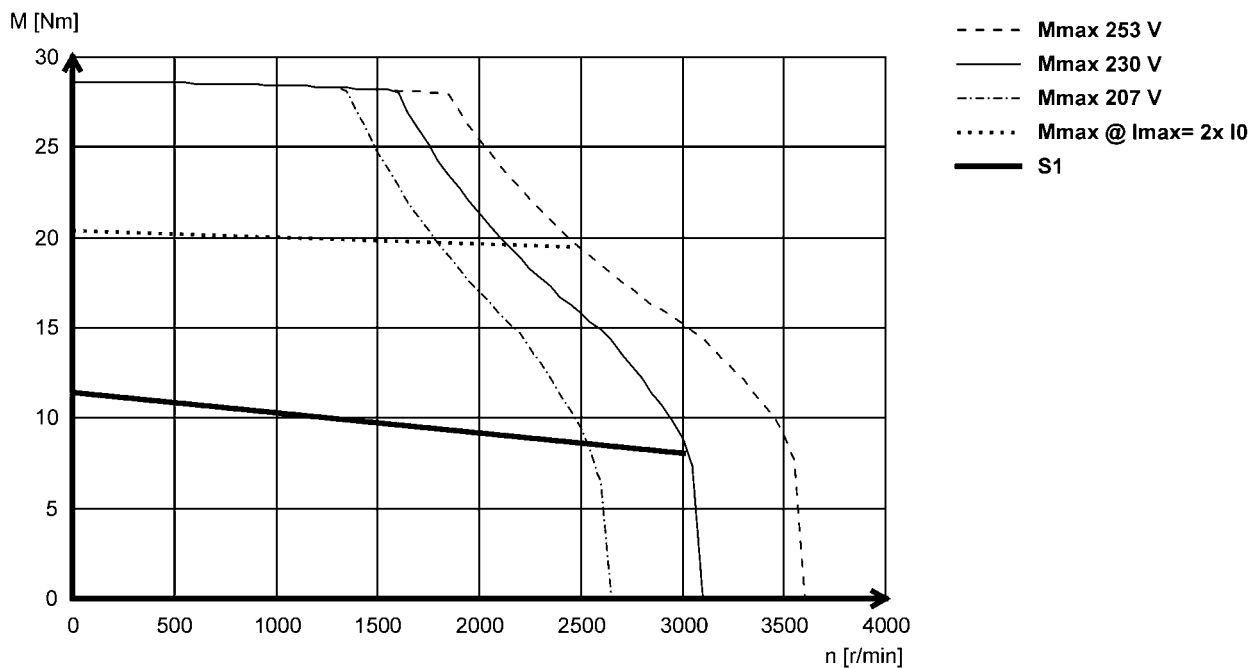

MCS synchronous servo motors

Technical data



Torque characteristics

- ▶ The data applies to a mains connection voltage of 3 x 230 V.
- ▶ You can find further torque characteristics at www.lenze.de/dsc.

MCS12L20L (non-ventilated)

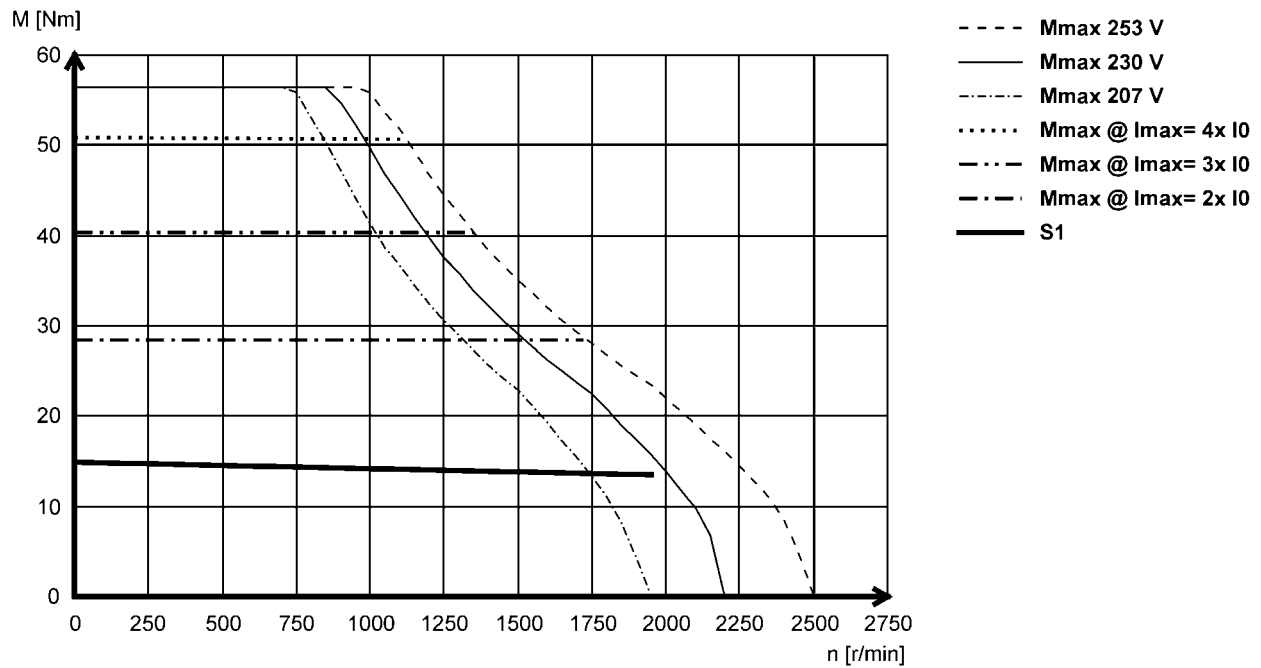

MCS synchronous servo motors

Technical data



Dimensions, self-ventilated

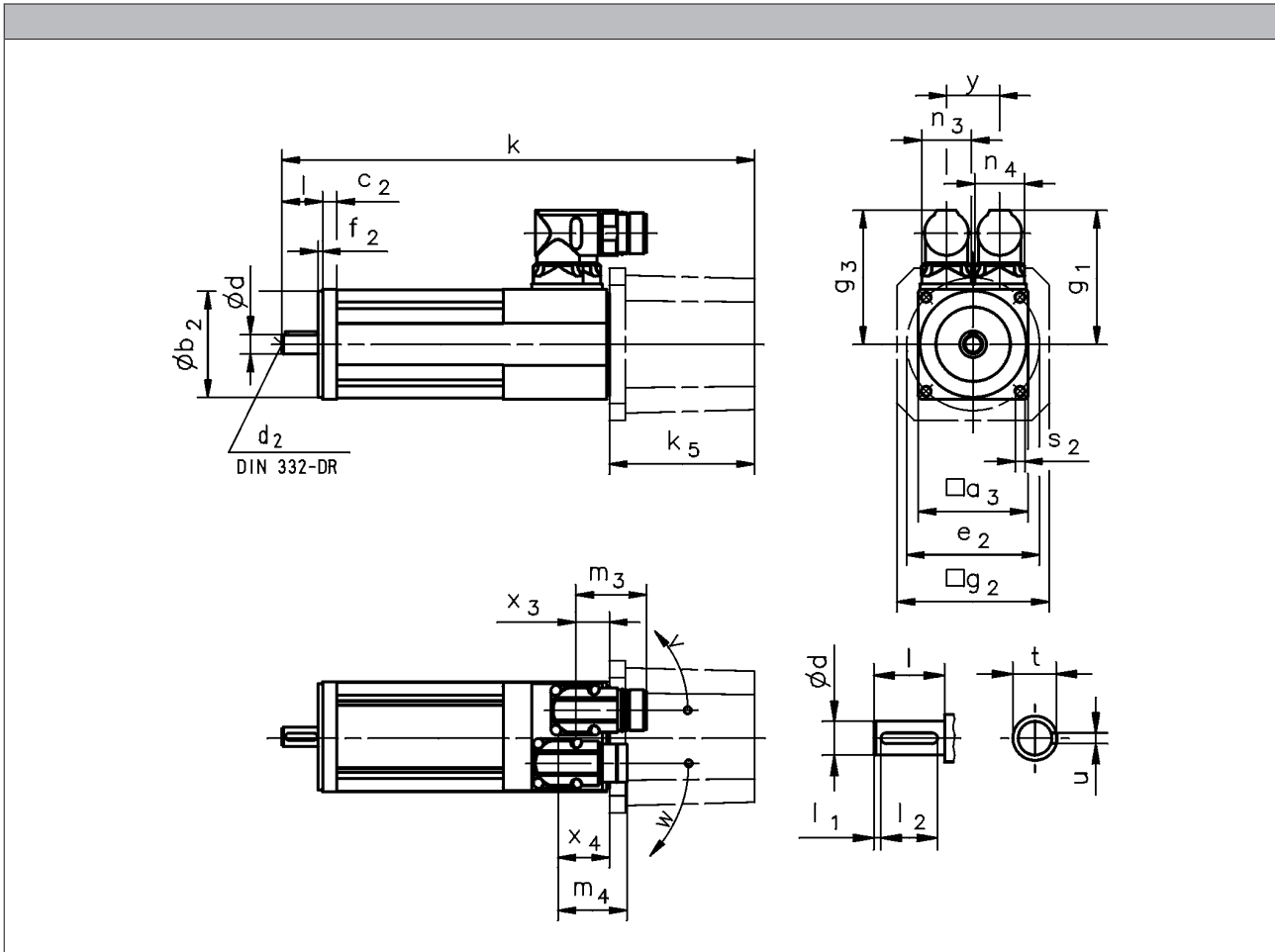

			MCS06C	MCS06F	MCS06I
R□□ / C40 B0	k	[mm]	155	185	215
R□□ / C40 P□	k	[mm]	174	204	233
SR□ / SV□ / E□□ B0	k	[mm]	237	266	297
SR□ / SV□ / E□□ P□	k	[mm]	255	285	315
SR□ / SV□ / E□□	k_5	[mm]		82.0	
	g_2	[mm]		86.0	
SKM B0	k	[mm]	190	220	250
SKM P□	k	[mm]	209	239	268
SKM	k_5	[mm]		35.0	
	g_2	[mm]		62.0	

- ▶ Speed / angle sensor: R□□ / C□□ / S□□ / E□□
- ▶ Brake: B0 / P□

MCS synchronous servo motors

Technical data



Dimensions, self-ventilated

	g ₁	g ₃	x ₃	x ₄	m ₃	m ₄	n ₃	n ₄	y	v	w
	[mm]	[mm]	[mm]	[mm]	[mm]	[mm]	[mm]	[mm]	[mm]	[°]	[°]
MCS06	77	77	19	29	40	40	28	28	30	190	230

	d	d ₂	l	l ₁	l ₂	u	t
	k6		-0.7 ... 0.3				
	[mm]	[mm]		[mm]	[mm]	[mm]	[mm]
MCS06	11	M4	23	2.0	18	4.0	12.5

	a ₃	b ₂	c ₂	e ₂	f ₂	s ₂
		j6				
	[mm]	[mm]	[mm]	[mm]	[mm]	[mm]
MCS06	62	60	8	75	2.5	5.5

MCS synchronous servo motors

Technical data



Dimensions, self-ventilated

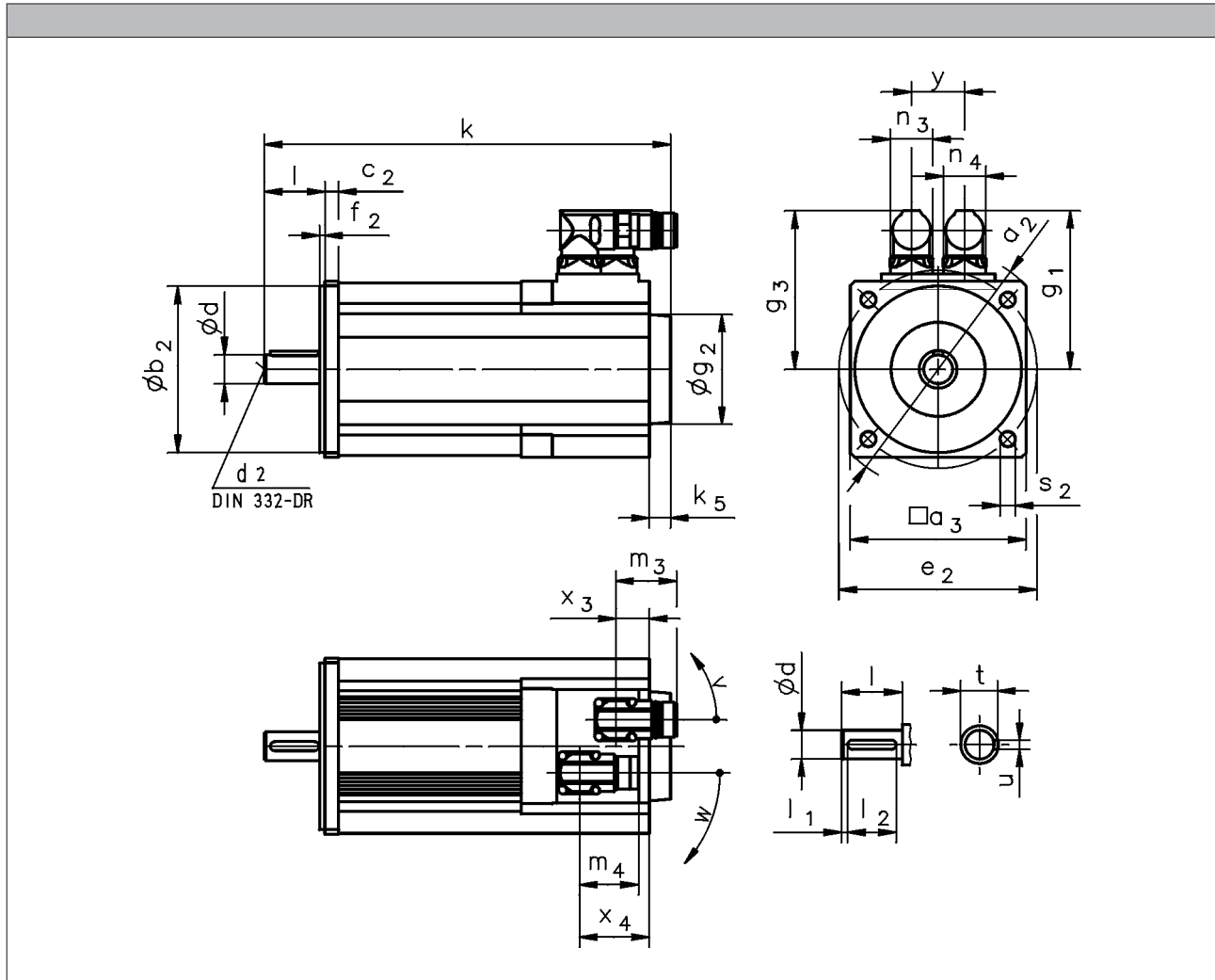

			MCS09D	MCS09F	MCS09H	MCS09L	MCS12D	MCS12H	MCS12L
R□□ / C40 B0	k	[mm]	213	233	253	293	228	268	308
R□□ / C40 P□	k	[mm]	233	253	273	313	248	288	328
R□□ / C40	k ₅	[mm]	13			14			
	g ₂	[mm]	67			72			
S□□ / E□□ B0	k	[mm]	264	284	304	344	277	317	357
S□□ / E□□ P□	k	[mm]	284	304	324	364	297	337	377
S□□ / E□□	k ₅	[mm]	64			63			
	g ₂	[mm]	81			89			

			MCS14D	MCS14H	MCS14L	MCS14P	MCS19F	MCS19J	MCS19P
R□□ / C40 B0	k	[mm]	251	291	331	371	280	320	380
R□□ / C40 P□	k	[mm]	279	319	359	399	314	364	424
R□□ / C40	k ₅	[mm]	24			15			
	g ₂	[mm]	78			78			
S□□ / E□□ B0	k	[mm]	301	341	381	421	329	369	429
S□□ / E□□ P□	k	[mm]	329	369	409	449	363	413	473
S□□ / E□□	k ₅	[mm]	74			64			
	g ₂	[mm]	101			101			

- ▶ Speed / angle sensor: R□□ / C□□ / S□□ / E□□
- ▶ Brake: B0 / P□

MCS synchronous servo motors

Technical data



Dimensions, self-ventilated

	g ₁	g ₃	x ₃	x ₄	m ₃	m ₄	n ₃	n ₄	y	v	w
	[mm]	[mm]	[mm]	[mm]	[mm]	[mm]	[mm]	[mm]	[mm]	[°]	[°]
MCS09	90	90	20	44	40	40	28	28	35	195	260
MCS12	105	105	22	46							

	g ₁	g ₃	x ₃	x ₄	m ₃	m ₄	n ₃	n ₄	y	v	w
	[mm]	[mm]	[mm]	[mm]	[mm]	[mm]	[mm]	[mm]	[mm]	[°]	[°]
MCS14D15-	117	117	24	48	40	40	28	28	35	195	260
MCS14D36-											
MCS14H15-											
MCS14H32-											
MCS14L15-											
MCS14L32-	146	126	29	36		75		45		180	205
MCS14P14-	117	117	24	48		40		28		195	260
MCS14P32-	146	126	29	36		75		45		180	205
MCS19F14-	142	142	24 51 ¹⁾	48 75 ¹⁾		40		28		195	260
MCS19F30-	171	151	29 56 ¹⁾	36 63 ¹⁾		75		45		180	205
MCS19J14-	142	142	24 51 ¹⁾	48 75 ¹⁾	40	28	195	260			
MCS19J30-	171	151	29 56 ¹⁾	36 63 ¹⁾	75	45	180	205			
MCS19P14-	142	142	24 51 ¹⁾	48 75 ¹⁾	40	28	195	260			
MCS19P30-	171	151	29 56 ¹⁾	36 63 ¹⁾	75	45	180	205			

	d	d ₂	l	l ₁	l ₂	u	t
	k6		-0.7 ... 0.3				
	[mm]	[mm]		[mm]	[mm]	[mm]	[mm]
MCS09	14	M5	30	2.5	25	5.0	16.0
MCS12	19	M6	40	4.0	32	6.0	21.5
MCS14	24	M8	50	5.0	40	8.0	27.0
MCS19	28	M10	60		50		31.0

	a ₂	a ₃	b ₂	c ₂	e ₂	f ₂	s ₂
			j6				
	[mm]	[mm]	[mm]	[mm]	[mm]	[mm]	[mm]
MCS09	120	89	80	8	100	3.0	7.0
MCS12	160	116	110	9	130	3.5	10.0
MCS14	188	143	130	13	165		12.0
MCS19	250	192	180	11	215	4.0	14.0

¹⁾ On version with brake (P□)

MCS synchronous servo motors

Technical data



Dimensions, forced ventilated

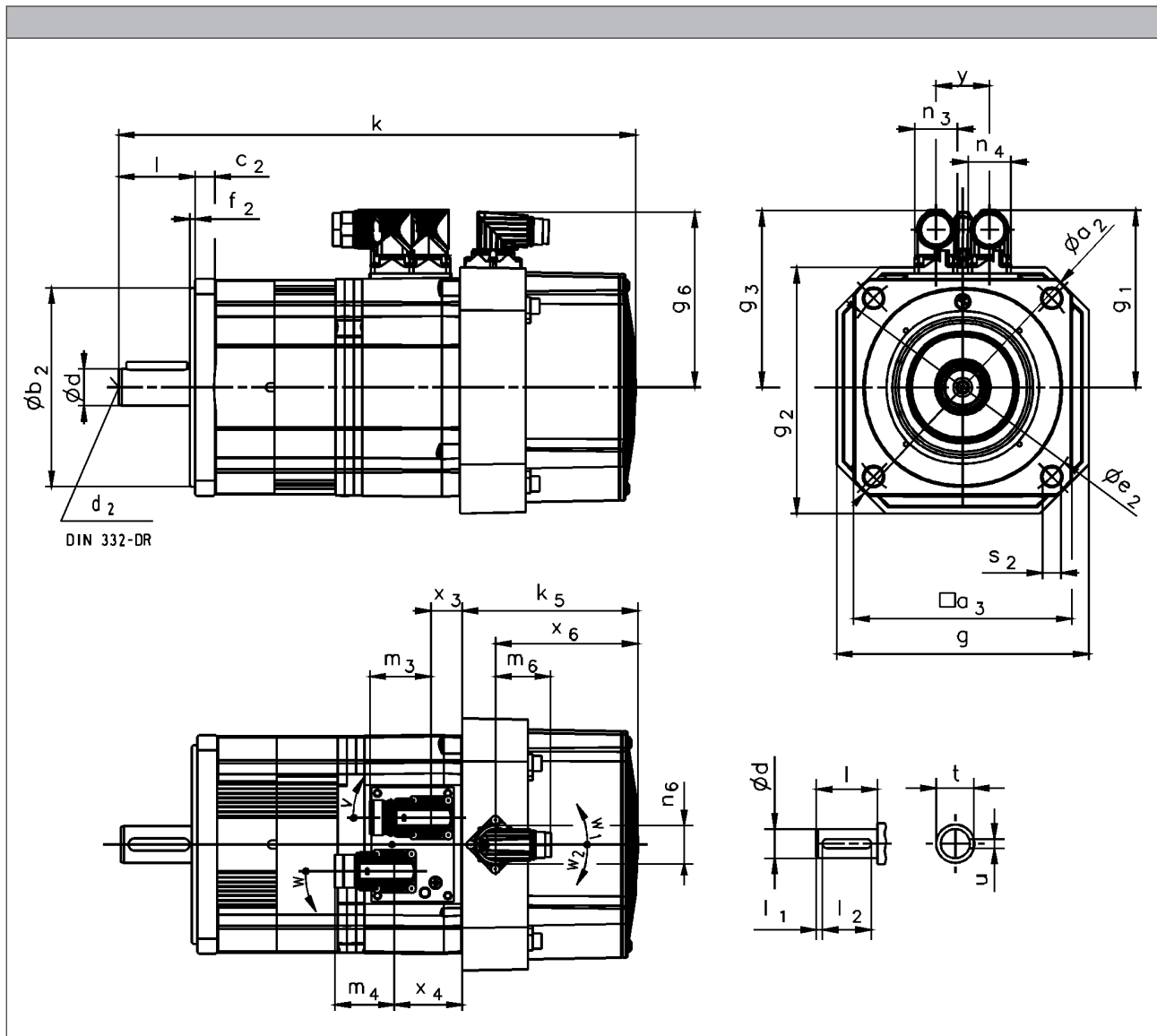

			MCS12D	MCS12H	MCS12L	MCS14D	MCS14H	MCS14L	MCS14P	MCS19F	MCS19J	MCS19P
R□□ / C40 B0	k	[mm]	301	341	381	339	379	419	459	387	427	487
R□□ / C40 P□	k	[mm]	321	361	401	368	408	448	488	421	471	531
R□□ / C40	k ₅	[mm]		92				115			126	
S□□ / E□□ B0	k	[mm]	344	384	424	392	432	472	512	425	465	525
S□□ / E□□ P□	k	[mm]	364	404	444	421	461	501	541	459	509	569
S□□ / E□□	k ₅	[mm]		135				169			165	
	g	[mm]		140				167			212	
	g ₂	[mm]		140				163			210	

- ▶ Speed / angle sensor: R□□ / C□□ / S□□ / E□□
- ▶ Brake: B0 / P□

MCS synchronous servo motors

Technical data



Dimensions, forced ventilated

	g ₁	g ₃	g ₆	x ₃	x ₄	x ₆	m ₃	m ₄	m ₆	n ₃	n ₄	n ₆	y	v	w	w ₁	w ₂																																															
	[mm]	[mm]	[mm]	[mm]	[mm]	[mm]	[mm]	[mm]	[mm]	[mm]	[mm]	[mm]	[mm]	[°]	[°]	[°]	[°]																																															
MCS12D17	105	105	107	16	40	67		40																																																								
MCS12D35																																																																
MCS12H14																																																																
MCS12H34																																																																
MCS12L17																																																																
MCS12L39																																																																
MCS14D14	117	117	115	20	44	93	40	40	37	28																																																						
MCS14D30																																																																
MCS14H12																																																																
MCS14H28	146	126		24	31		93												40	75	37	28																																										
MCS14L14	117	117																														20	44	40	40	37	28																											
MCS14L30	146	126																																													24	31	40	75	37	28												
MCS14P11	117	117	20	44	40	40		37	28																																																							
MCS14P26	146	126																24	31													40	75	37													28																	
MCS19F12	142	142	142	19																																													43															
MCS19F29																																																																
MCS19J12	171	151		142	24		31											96	51 ¹⁾	58 ¹⁾	75	37	28																																									
MCS19J29																																																																
MCS19P12																																																																
MCS19P29																																																																

	d	d ₂	l	l ₁	l ₂	u	t
	k6		-0.7 ... 0.3				
	[mm]	[mm]		[mm]	[mm]	[mm]	[mm]
MCS12	19	M6	40	4.0	32	6.0	21.5
MCS14	24	M8	50	5.0	40	8.0	27.0
MCS19	28	M10	60		50		31.0

	a ₂	a ₃	b ₂	c ₂	e ₂	f ₂	s ₂
			j6				
	[mm]	[mm]	[mm]	[mm]	[mm]	[mm]	[mm]
MCS12	160	116	110	9	130	3.5	10.0
MCS14	188	143	130	13	165		12.0
MCS19	250	192	180	11	215	4.0	14.0

¹⁾ On version with brake (P□)

MCS synchronous servo motors

Technical data





Permanent magnet holding brake

The synchronous servo motor can be fitted with integral permanent magnet holding brakes.

In the case of permanent magnet brakes, the rated torque applies solely as holding torque at standstill. This is due to the nature of their design. During braking from full motor speed, e.g. in the event of emergency stops, the braking torque is significantly reduced.

As such, they may not be used as safety elements (particularly with lifting axes) without additional measures being implemented.

The brakes are activated when the supply voltage is disconnected (closed-circuit principle). When using the brakes purely as holding brakes, virtually no wear occurs on the friction surfaces.

For traversing axes, adherence to the permissible load/brake motor (J_L / J_{MB}) moment of inertia ensures that the permissible maximum switching rate of the brake will not be exceeded and at least 2,000 emergency stop functions can be performed from a speed of 3,000 rpm.

For lifting axes, the load torque resulting from the weight acts additionally. In this case the specifications for J_L / J_{MB} do not apply.

Caution:

The brakes used are not safety brakes in the sense that a reduction in torque may arise as a result of disruptive factors that cannot be influenced, e.g. oil ingress.

The ohmic voltage drop along the cable must be taken into consideration in long motor supply cables and must be compensated for by a higher voltage at the line input.

The following applies for Lenze system cables:

$$U[V] = U_B[V] + 0.08 \frac{[V]}{[A] \cdot [m]} \cdot I_{Lg}[m] \cdot I_B[A]$$

If no suitable voltage (incorrect value, incorrect polarity) is applied to the brake, the brake will be applied and can be overheated and destroyed by the motor continuing to rotate.

The shortest switching times of the brakes are achieved by DC switching of the voltage. A spark suppressor is required to suppress interference and to increase the service life of the relay contacts here.



Permanent magnet holding brake



Permanent magnet holding brake

Rated data with standard braking torque

	U _{N,DC} ^{3,5)}	M _N	M _N	M _{av}	I _N ²⁾	J	t ₁ ¹⁾	t ₂ ¹⁾	Q _E ⁴⁾	m	J _{MB}	J _L /J _{MB}
		20 °C	120 °C	120 °C								
	[V]	[Nm]	[Nm]	[Nm]	[A]	[kgcm ²]	[ms]	[ms]	[J]	[kg]	[kgcm ²]	
MCS06C	24	2.20	2.00	0.60	0.34	0.12	15.0	30.0	30.0	0.30	0.26	22.1
MCS06F											0.34	16.6
MCS06I											0.42	13.3
MCS09D		8.00	6.00	4.50	0.65	1.07	20.0	40.0	400	0.80	2.17	36.4
MCS09F											2.57	30.5
MCS09H											2.97	26.3
MCS09L											3.87	19.9
MCS12D		12.0	10.0	7.00	0.65	1.07	13.0	43.0	400	0.90	5.07	15.0
MCS12H											8.40	8.70
MCS12L											11.7	5.90
MCS14D		22.0	18.0	8.00	0.88	3.20	15.0	150	640	1.90	11.3	10.5
MCS14H											17.4	6.50
MCS14L											26.6	3.90
MCS14P											37.9	2.40
MCS19F											37.0	32.0

Rated data with increased braking torque

	U _{N,DC} ^{3,5)}	M _N	M _N	M _{av}	I _N ²⁾	J	t ₁ ¹⁾	t ₂ ¹⁾	Q _E ⁴⁾	m	J _{MB}	J _L /J _{MB}
		20 °C	120 °C	120 °C								
	[V]	[Nm]	[Nm]	[Nm]	[A]	[kgcm ²]	[ms]	[ms]	[J]	[kg]	[kgcm ²]	
MCS09D	24	12.0	10.0	7.00	0.65	1.07	20.0	40.0	400	0.80	2.17	36.4
MCS09F											2.57	30.5
MCS09H											2.97	26.3
MCS09L											3.87	19.9
MCS12D		24.0	19.0	12.0	0.71	3.13	16.0	90.0	890	1.20	7.10	24.3
MCS12H											10.4	16.3
MCS12L											13.7	12.1
MCS14D		37.0	32.0	15.0	0.93	12.4	96.0	113	2350	3.10	20.5	22.2
MCS14H											26.6	16.9
MCS14L											35.8	12.3
MCS14P											47.1	9.10
MCS19J											100	80.0
MCS19P		190	1.20									

1) Engagement and disengagement times are valid for rated voltage (± 0 %) and protective circuit for brakes with varistor for DC switching. The times may increase without a protective circuit.

2) The currents are the maximum values when the brake is cold (value used for dimensioning the current supply). The values for a motor at operating temperature are considerably lower.

3) With 24V DC brake: smoothed DC voltage, ripple ≤ 1 %.

4) Maximum switching energy per emergency stop at n = 3000 r/min for at least 2000 emergency stops.

5) Voltage tolerance: -10% to +5%

MCS synchronous servo motors

Accessories



Resolver

Stator-fed resolver with two stator windings offset by 90° and one rotor winding with transformer winding.

Speed/angle sensor				RS0	RV0
	1)				
Product key				RS0	RV03
Resolution					
Angle			[°]	0.80	
Accuracy			[°]	-10 ... 10	
Absolute positioning				1 revolution	
Max. speed		n_{max}	[r/min]	8000	
Max. input voltage					
DC		$U_{in,max}$	[V]	10.0	
Max. input frequency					
		$f_{in,max}$	[kHz]	4.00	
Ratio					
Stator / rotor			± 5 %	0.30	
Rotor impedance					
		Z_{ro}	[Ω]	51 + j90	
Stator impedance					
		Z_{so}	[Ω]	102 + j150	
Impedance					
		Z_{rs}	[Ω]	44 + j76	
Min. insulation resistance					
At DC 500 V		R	[MΩ]	10.0	
Number of pole pairs				1	
Max. angle error			[°]	-10 ... 10	
Inverter assignment				E84AVTC E94A ECS EVS93	

1)  6 - Product key > speed/angle sensor

Speed-dependent safety functions

Suitable for safety function			No	Yes
Max. permissible angular acceleration				
MCS06		α		56 000
MCS09 ... MCS19 ²⁾		α		19 000
Functional safety				
IEC 61508				SIL3
EN 13849-1				Up to Performance Level e

2)  10 - Single encoder concepts with resolvers



Incremental encoder and SinCos absolute value encoder

Encoder type			TTL incremental	SinCos absolute value		
Speed/angle sensor			C40	EQI	SRS	SVS
Product key			IK4096-5V-T	AM32-5V-E	AS1024-8V-H	AS1024-8V-K2
Encoder type			Single-turn	Multi-turn	Single-turn	
Pulses			4096	32	1024	
Output signals			TTL	1 V _{ss}		
Interfaces				EnDat	Hiperface	
Absolute revolutions			0	4096	1	
Resolution						
Angle ²⁾		[°]	1.30	0.40		
Accuracy						
		[°]	-1 ... 1	-5 ... 5	-0.8 ... 0.8	
Min. input voltage						
DC	U _{in,min}	[V]	4.50	4.75	7.00	
Max. input voltage						
DC	U _{in,max}	[V]	5.50	5.25	12.0	
Max. speed						
	n _{max}	[r/min]	7324	12000	6000	
Max. current consumption						
	I _{max}	[A]	0.075	0.17	0.080	
Limit frequency						
	f _{max}	[kHz]	500	6.00	200	
Inverter assignment						
			E94P	E94A	E84AVTC E94A ECS EVS93	

1) 6 - Product key > speed/angle sensor

2) Inverter-dependent.

Speed-dependent safety functions

Suitable for safety function			No	No	No	Yes
Max. permissible angular acceleration						
MCS06	α	[rad/s ²]				970000
MCS09 ... MCS19	α	[rad/s ²]				240000
Functional safety						
IEC 61508						SIL2
EN 13849-1						Up to Performance Level d

MCS synchronous servo motors

Accessories



Incremental encoder and SinCos absolute value encoder

Encoder type			SinCos absolute value				
Speed/angle sensor			SKM	SRM	SVM	ECN	EQN
Product key			AM128-8V-H	AM1024-8V-H	AM1024-8V-K2	AS2048-5V-E	AM2048-5V-E
Encoder type			Multi-turn			Single-turn	Multi-turn
Pulses			128	1024	2048		
Output signals			1 Vss				
Interfaces			Hiperface			EnDat	
Absolute revolutions			4096			1	4096
Resolution			0.40				
Angle			[°]				
Accuracy			-1.3 ... 1.3		-0.8 ... 0.8		-0.6 ... 0.6
Min. input voltage							
DC	$U_{in,min}$	[V]	7.00			4.75	
Max. input voltage							
DC	$U_{in,max}$	[V]	12.0			5.25	
Max. speed							
	n_{max}	[r/min]	9000	6000	12000		
Max. current consumption							
	I_{max}	[A]	0.060	0.080	0.15	0.25	
Limit frequency							
	f_{max}	[kHz]	200				
Inverter assignment			E84AVTC E94A ECS EVS93			E94A	

¹⁾ Inverter-dependent.

Speed-dependent safety functions

Suitable for safety function			No	No	Yes	No	No
Max. permissible angular acceleration							
MCS06	α	[rad/s ²]	970000				
MCS09 ... MCS19	α	[rad/s ²]	240000				
Functional safety							
IEC 61508			SIL2				
EN 13849-1			Up to Performance Level d				

6.11

MCS synchronous servo motors

Accessories



Blowers

Rated data for 50 Hz

		Enclosure	Number of phases	U_{min}	U_{max}	$U_{N, AC}$	P_N	I_N
				[V]	[V]	[V]	[kW]	[A]
MCS12	F10	IP54	1	210	240	230	0.019	0.12
	F50			104	122	115	0.018	0.22
MCS14	F10			210	240	230	0.040	0.25
	F50			104	122	115		0.53
MCS19	F10			210	240	230	0.060	0.26
	F50			104	122	115	0.047	0.45

Rated data for 60 Hz

		Enclosure	Number of phases	U_{min}	U_{max}	$U_{N, AC}$	P_N	I_N
				[V]	[V]	[V]	[kW]	[A]
MCS12	F10	IP54	1	210	240	230	0.019	0.12
	F50			104	122	115	0.018	0.22
MCS14	F10			210	240	230	0.040	0.25
	F50			104	122	115		0.53
MCS19	F10			210	240	230	0.060	0.26
	F50			104	122	115	0.047	0.45

MCS synchronous servo motors

Accessories



Temperature monitoring

The thermal sensors used in the MCS motors continuously monitor the motor temperature. The temperature signal is transmitted over the system cable of the feedback system to the servo controller. Because of the different physical conditions, there are two temperature monitoring mechanisms on the MCS motors (there is no complete motor protection in either case)

MCS06

on this motor, the winding temperature of one winding phase is monitored with a KTY 83-110 type thermal sensor.

MCS09 to 19

These motors are monitored by three thermal sensors (1x KTY 83-110 + 2x PTC 150 °C) connected in series. This means that the temperature of the motor is determined with great accuracy in the permitted operating range and at the same time the overtemperature response configured in the controller is executed in the event of overtemperature in one of the winding phases.

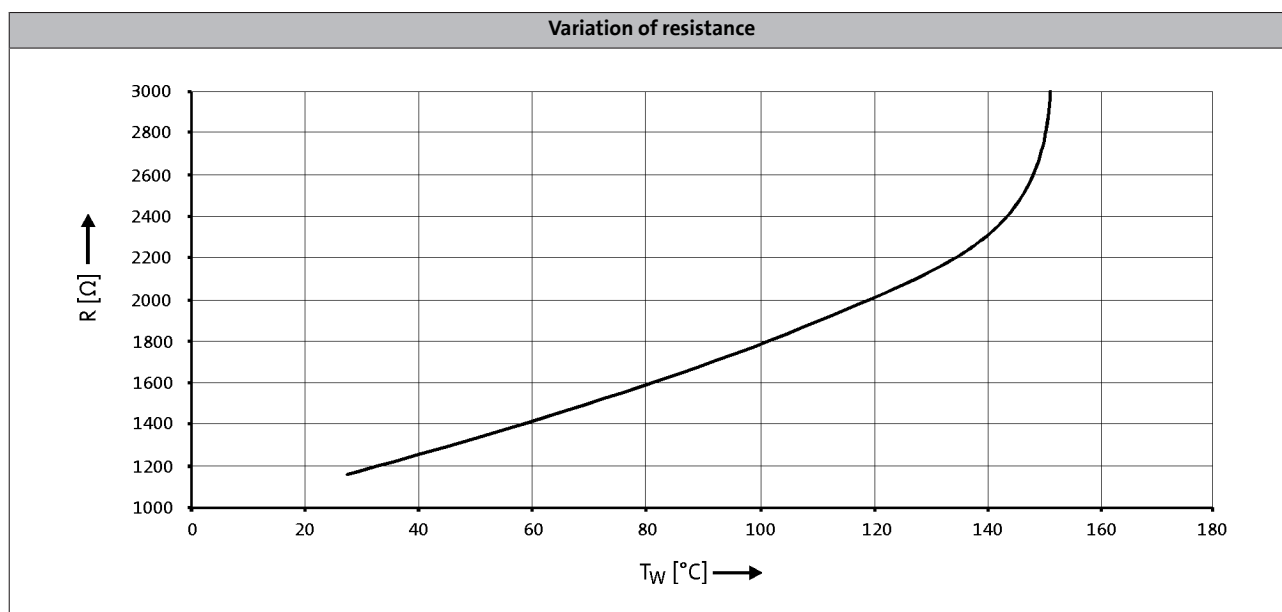

- ▶ If the detector is supplied with a measured current of 1 mA, the above relationship between the temperature and the resistance applies.

MCS synchronous servo motors

Accessories



Terminal box

If a servo motor is to be connected to an existing cable or plug connectors are not to be used for other reasons, the connection can also be made via a terminal box.

The terminals are designed as tension spring terminals to ensure here the long-term vibration resistance of the cable contacts with adequate contact pressure required.

The terminal boxes have generously dimensioned space for the customer's own wiring and large surface shield connection areas to ensure a secure EMC-compliant connection. The cable outlet may be to the left or to the right, depending on requirements.

It is not possible to attach a terminal box to the MCS06 or to models with the blower.

Connections

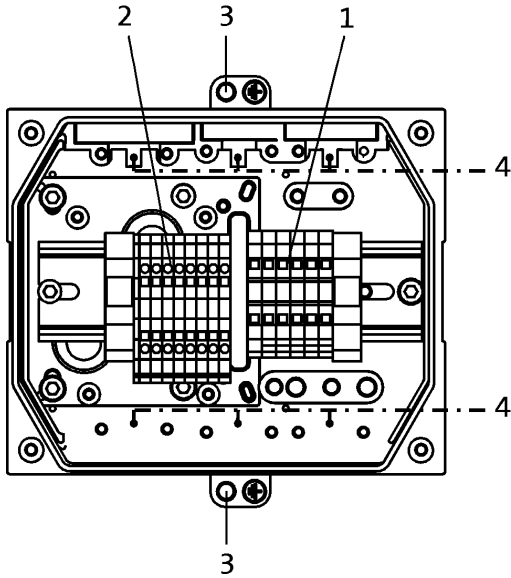

1: Power connection (terminals loadable up to 65 A) + brake connection.

2: Angle/speed sensor connection + thermal sensor connection.

3: PE connection.

4: Large area shield contact.

5: Openings for 2x M32, 2x M25, 2x M20 fittings. The openings are plugged and can be opened up as required by the customer.

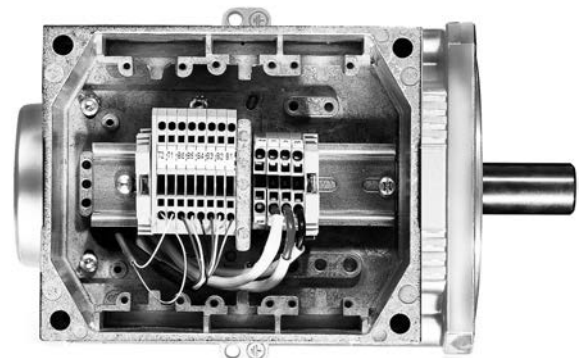
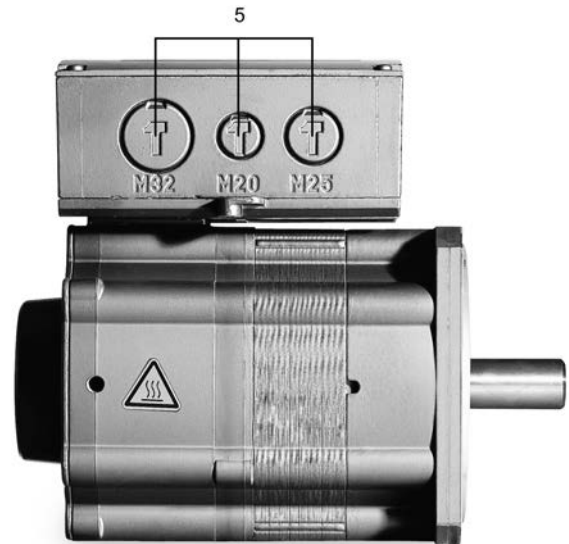

MCS synchronous servo motors

Accessories



Terminal box

Dimensions

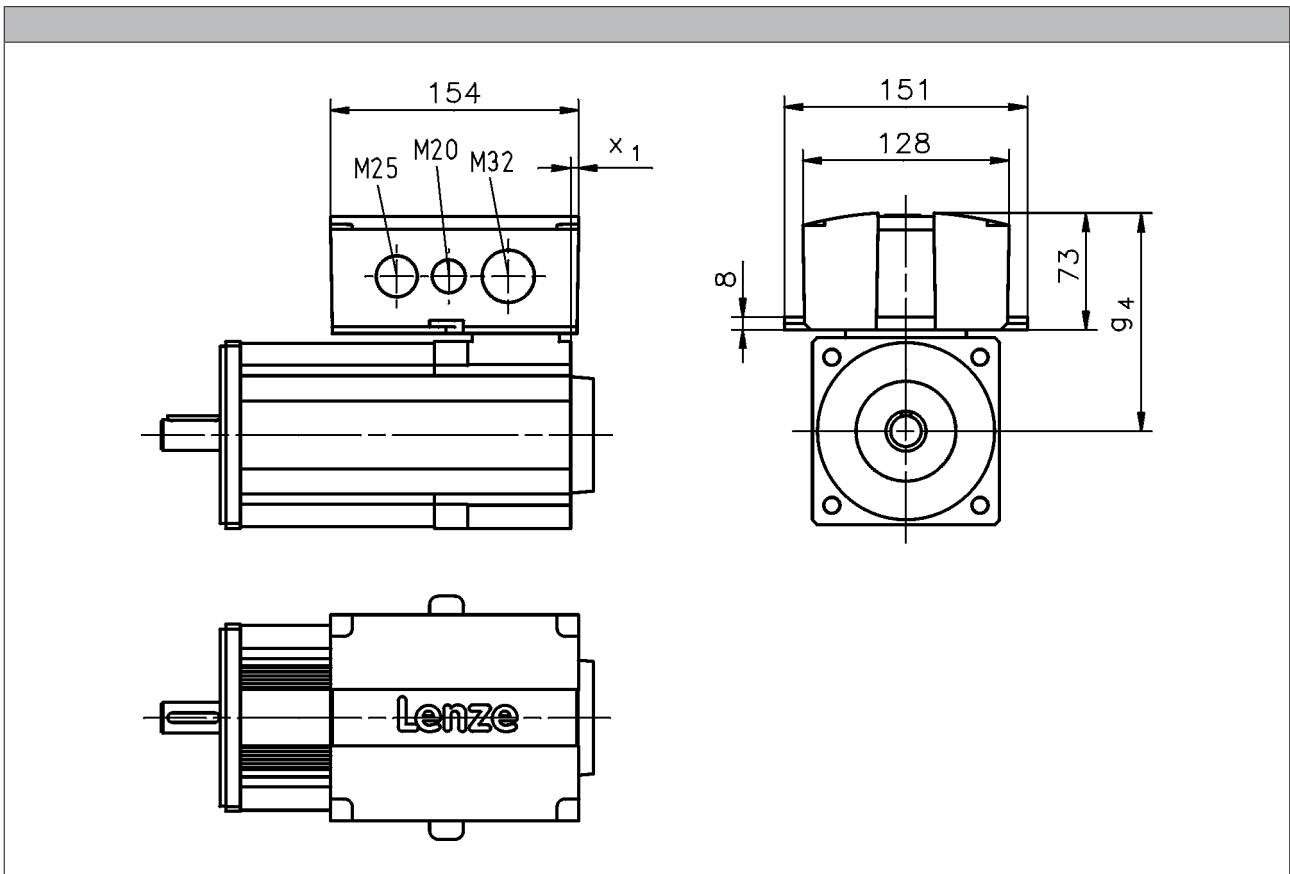

	g_4 [mm]	x_1 [mm]
MCS09	121	8
MCS12	136	5
MCS14	147	3
MCS19	172	

MCS synchronous servo motors

Accessories



ICN connector

An ICN connector is used as standard for the electrical connection to the servo motors.

A connector is used for the connection of motor and brake. The connections to the feedback system/temperature monitoring and the blower each employ a separate connector.

The connectors can be rotated through 270° and are fitted with a bayonet catch for SpeedTec connectors. As the connector fixing is also compatible with conventional union nuts. Existing mating connectors can therefore still be used without difficulty.

Connection for power and brake

► MCS06 to 12

Pin assignment			
Contact	Designation	Meaning	
1	BD1	Holding brake +	
2	BD2	Holding brake -	
PE	PE	PE conductor	
4	U	Phase U power	
5	V	Phase V power	
6	W	Phase W power	

► MCS14 to 19

Pin assignment			
Contact	Designation	Meaning	
1		Not assigned	
2			
+	BD1	Holding brake +	
-	BD2	Holding brake -	
PE	PE	PE conductor	
U	U	Phase U power	
V	V	Phase V power	
W	W	Phase W power	

MCS synchronous servo motors

Accessories



ICN connector

Feedback connection

► Resolver

Pin assignment		
Contact	Designation	Meaning
1	+Ref	Transformer windings
2	-Ref	
3	+VCC ETS	Supply: Electronic nameplate
4	+COS	Cosine stator windings
5	-COS	
6	+SIN	Sine stator windings
7	-SIN	
8		Not assigned
9		
10		
11	+KTY	KTY temperature sensor
12	-KTY	

► Hiperface incremental encoder and SinCos absolute value encoder

Pin assignment		
Contact	Designation	Meaning
1	B	Track B/+SIN
2	A ⁻	Track A inverse/-COS
3	A	Track A/+COS
4	+U _B	Supply +
5	GND	Mass
6	Z ⁻	Zero track inverse/-RS485
7	Z	Zero track/+RS485
8		Not assigned
9	B ⁻	Track B inverse/-SIN
10		Not assigned
11	+KTY	KTY temperature sensor
12	-KTY	

MCS synchronous servo motors

Accessories



ICN connector

Feedback connection

- SinCos absolute value encoder with EnDat interface

Pin assignment		
Contact	Designation	Meaning
1	U _p sensor	Supply: UP sensor
2		Not assigned
3		
4	0 V sensor	Supply: 0 V sensor
5	+KTY	KTY temperature sensor
6	-KTY	
7	+U _B	Supply +
8	Cycle	EnDat interface cycle
9	Cycle ⁻	EnDat interface inverse cycle
10	GND	Mass
11	Shield	Encoder housing screen
12	B	Track B
13	B ⁻	Track B inverse/-SIN
14	Data	EnDat interface data
15	A	Track A
16	A ⁻	Track A inverse
17	Data ⁻	EnDat interface inverse data

Blower connection

Pin assignment		
Contact	Designation	Meaning
PE	PE	PE conductor
1	U1	Fan
2	U2	
3		Not assigned
4		
5		
6		

MCS synchronous servo motors

Accessories



MCS synchronous servo motors

Accessories



Motors

MCA asynchronous servo motors

2 to 1,100 Nm

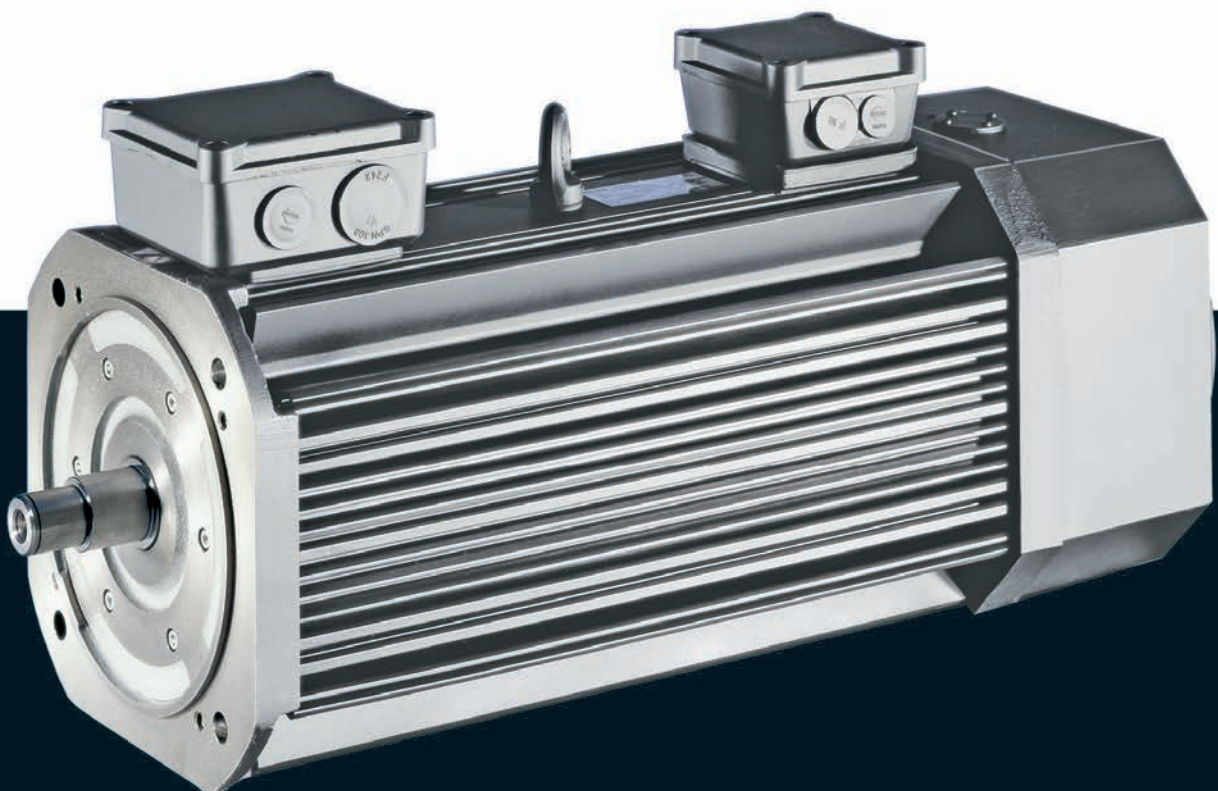

MCA asynchronous servo motors



Contents

General information	List of abbreviations	6.11 - 4	
	Product key	6.11 - 6	
	Product information	6.11 - 8	
	Functions and features	6.11 - 9	
	Dimensioning	6.11 - 11	
Technical data	Standards and operating conditions	6.11 - 19	
	Permissible radial and axial forces	6.11 - 20	
	Rated data, non-ventilated	6.11 - 22	
	Rated data, IP54 forced ventilated	6.11 - 23	
	Rated data, IP23s forced ventilated	6.11 - 24	
	Selection tables, Servo Drives 9400 HighLine	6.11 - 25	
	Selection tables, Inverter Drives 8400 TopLine	6.11 - 32	
	Selection tables, Servo Drives ECS	6.11 - 38	
	Selection tables, Servo Inverter 9300	6.11 - 41	
	Torque characteristics	6.11 - 47	
	Dimensions, self-ventilated	6.11 - 66	
	Dimensions, forced ventilated	6.11 - 68	
	Accessories	Permanent magnet holding brake	6.11 - 75
		Spring-applied holding brake	6.11 - 78
Resolver		6.11 - 80	
Incremental encoder and SinCos absolute value encoder		6.11 - 81	
Blowers		6.11 - 83	
Temperature monitoring		6.11 - 84	
Terminal box		6.11 - 85	
ICN connector	6.11 - 87		



List of abbreviations

$\eta_{100\%}$	[%]	Efficiency
$\cos \varphi$		Power factor
du/dt	[kV/ μ s]	Insulation resistance
$F_{ax,-}$	[N]	Min. axial force
$F_{ax,+}$	[N]	Max. axial force
$f_{in,max}$	[Hz]	Max. input frequency
f_{max}	[kHz]	Limit frequency
f_{max}	[kHz]	Max. switching frequency
f_N	[Hz]	Rated frequency
F_{rad}	[N]	Max. radial force
H_{max}	[m]	Site altitude
I_0	[A]	Standstill current
I_{max}	[A]	Max. short-time DC-bus current
I_{max}	[A]	Max. current
I_{max}	[A]	Max. current consumption
I_{max}	[A]	Max. current
I_{max}	[A]	Max. DC-bus current
I_N	[A]	Rated current
J	[kgcm ²]	Moment of inertia
J_{MB}	[kgcm ²]	Moment of inertia
$KE_{LL 150\text{ }^\circ\text{C}}$	[V / 1000 rp]	Voltage constant
$Kt_{0 150\text{ }^\circ\text{C}}$	[Nm/A]	Torque constant
L	[mH]	Mutual inductance
$L_{1\sigma}$	[mH]	Stator leakage inductance
$L_{2\sigma}$	[mH]	Rotor leakage inductance
L_N	[mH]	Rated inductance
m	[kg]	Mass
M_0	[Nm]	Stall torque
$M_{0,max}$	[Nm]	Max. standstill torque
M_{av}	[Nm]	Average dynamic torque
M_{max}	[Nm]	Max. torque
M_N	[Nm]	Rated torque
n_{eto}	[r/min]	Transition speed
n_k	[r/min]	Speed
n_{max}	[r/min]	Max. speed

n_N	[r/min]	Rated speed
P_N	[kW]	Rated power
Q_E	[J]	Maximum switching energy
R	[Ω]	Insulation resistance
R	[Ω]	Min. insulation resistance
R_1	[Ω]	Stator impedance
R_2	[Ω]	Charging resistor
R_2	[Ω]	Rotor impedance
$R_{UV 150\text{ }^\circ\text{C}}$	[Ω]	Stator impedance
$R_{UV 20\text{ }^\circ\text{C}}$	[Ω]	Stator impedance
$S_{h\u00fc}$	[1/h]	Transition operating frequency
T	[$^\circ\text{C}$]	Operating temperature
T	[$^\circ\text{C}$]	Rated temperature
T	[$^\circ\text{C}$]	Max. ambient temperature of bearing
T	[$^\circ\text{C}$]	Max. surface temperature
T	[$^\circ\text{C}$]	Max. ambient temperature for transport
T	[$^\circ\text{C}$]	Min. ambient storage temperature
T	[$^\circ\text{C}$]	Min. ambient temperature for transport
T	[$^\circ\text{C}$]	Ambient temperature
t_1	[ms]	Engagement time
t_2	[ms]	Disengagement time
$T_{opr,max}$	[$^\circ\text{C}$]	Max. ambient operating temperature
$T_{opr,min}$	[$^\circ\text{C}$]	Min. ambient operating temperature
$U_{in,max}$	[V]	Max. input voltage
$U_{in,min}$	[V]	Min. input voltage
U_{max}	[V]	Max. mains voltage
U_{max}	[V]	Min. input voltage
U_{min}	[V]	Min. mains voltage
$U_{N, AC}$	[V]	Rated voltage
$U_{N, DC}$	[V]	Rated voltage
Z_{ro}	[Ω]	Rotor impedance
Z_{rs}	[Ω]	Impedance
Z_{so}	[Ω]	Stator impedance

MCA asynchronous servo motors

General information



List of abbreviations

CE	Communauté Européenne
CSA	Canadian Standards Association
DIN	Deutsches Institut für Normung e.V.
EMC	Electromagnetic compatibility
EN	European standard
GOST	Certificate for Russian Federation
IEC	International Electrotechnical Commission
IM	International Mounting Code
IP	International Protection Code
NEMA	National Electrical Manufacturers Association
UkrSEPRO	Certificate for Ukraine
UL	Underwriters Laboratory Listed Product
UR	Underwriters Laboratory Recognized Product
VDE	Verband deutscher Elektrotechniker (Association of German Electrical Engineers)

MCA asynchronous servo motors

General information



Product key

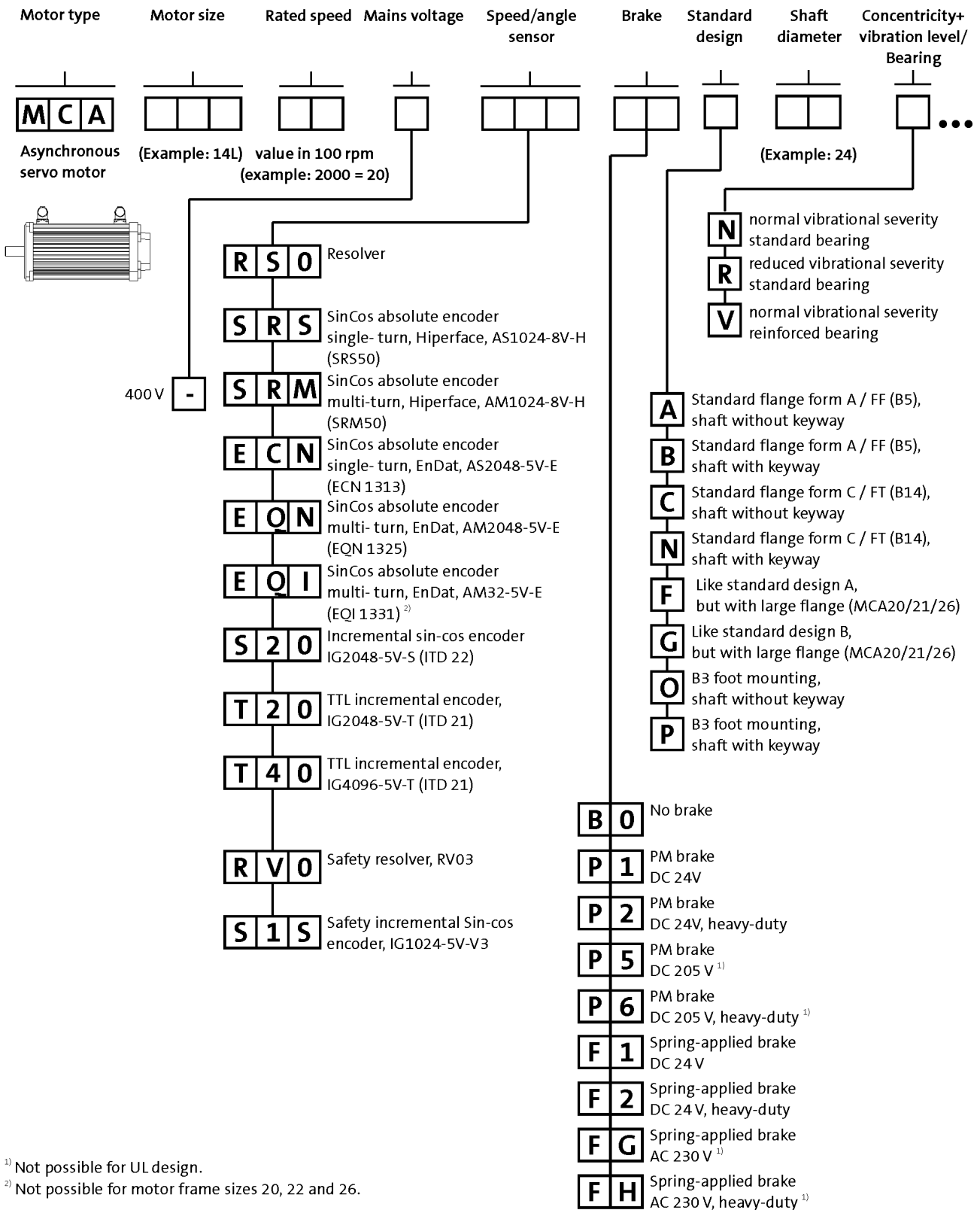

6.11

¹⁾ Not possible for UL design.

²⁾ Not possible for motor frame sizes 20, 22 and 26.

MCA asynchronous servo motors

General information



Product key

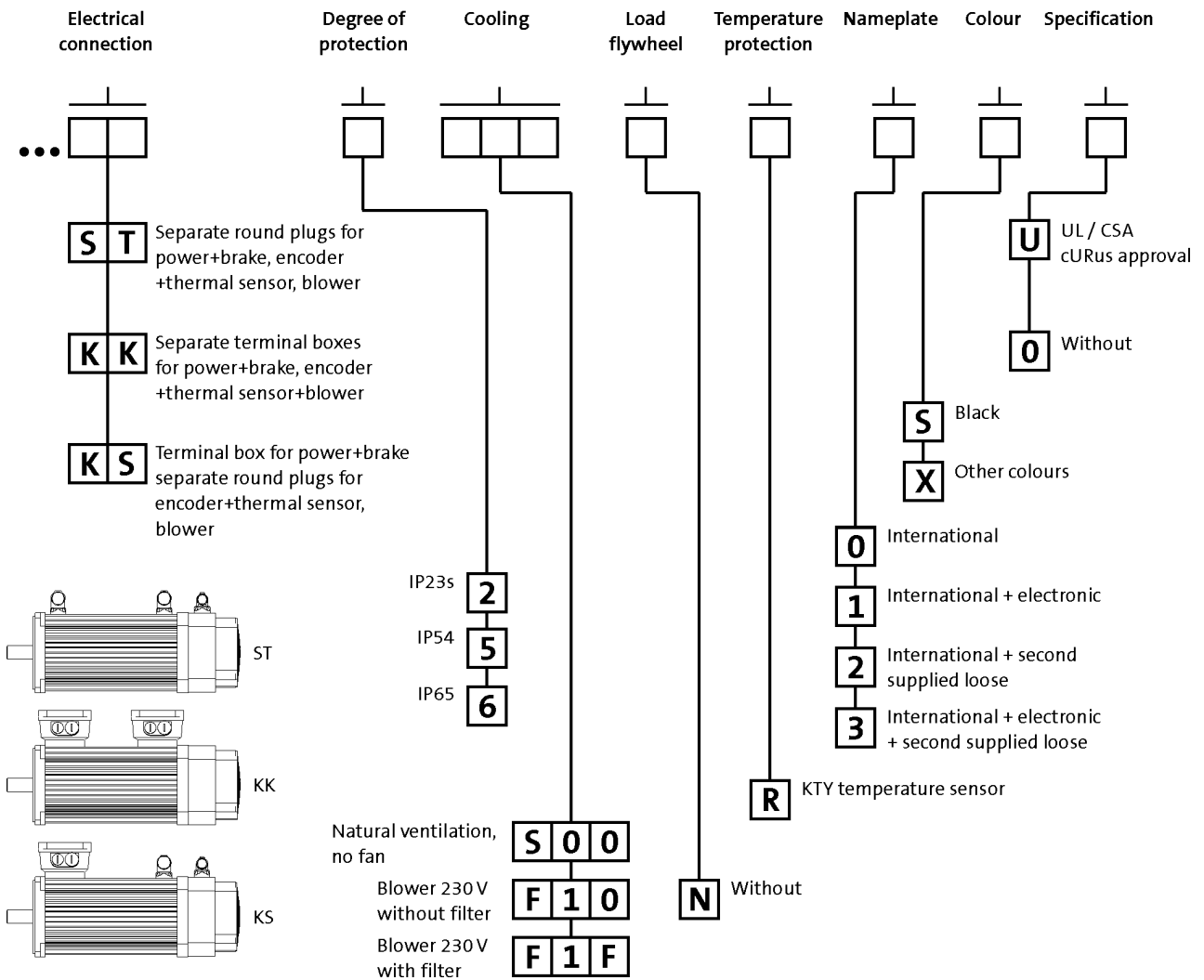

MCA asynchronous servo motors

General information



Product information

An application-oriented structure, low moments of inertia, compact dimensions and a high degree of intrinsic operational reliability characterise these robust and dynamic motors.

The compact design and the low moment of inertia allow these motors to be used in dynamic applications. If your application calls for a broad speed setting range and a robust construction, then the choice is easy: MCA asynchronous servo motors from Lenze.

Whether as a self-ventilated version or with a blower – with a power range from 0.8 to 53.8 kW, the MCA asynchronous servo motors offer rated torque values of up to 280 Nm and peak torque values of up to 1100 Nm. In comparison to standard three-phase AC motors, these servo motors have the edge in terms of lower moments of inertia, lower weight and higher maximum speeds.

Advantages

- High dynamic performance thanks to low moments of inertia
- Compact size with high power density
- Robust regenerative resolver system – alternatively SinCos and incremental encoder for the highest precision
- Easy to install and service friendly thanks to use of SpeedTec connectors
- Terminal box optional up to MCA21 MCA22 and 26 with three-part terminal box
- Protection: IP23, IP54, IP65 optional for naturally ventilated servo motors
- cURus-approved, GOST-certified, CE, RoHS-compliant
- High maximum speeds
- Wide speed setting range
- Field weakening operation usable
- Electronic nameplate

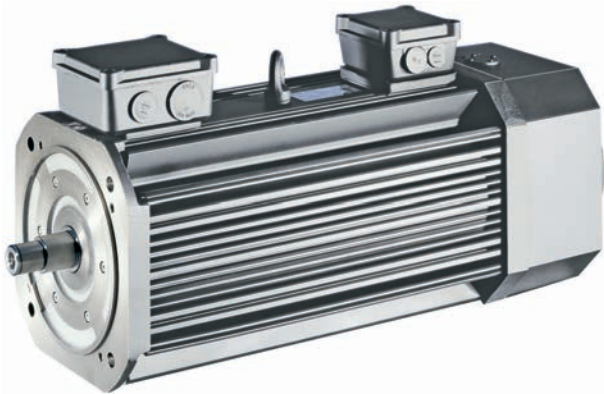

MCA21 asynchronous servo motor

MCA asynchronous servo motors

General information



Functions and features

	MCA10	MCA13	MCA14	MCA17	MCA19
Design					
	B14-FT85 B5-FF100	B14-FT130 B5-FF130	B14-FT130 B5-FF165		B14-FT130 B5-FF215
Shaft end (with and without keyway)					
	14 x 30	19 x 40	24 x 50		28 x 60
A end shield	Oil-tight Not oil-tight				
Brake					
Spring-applied brake					
Permanent magnetic brake	DC 24 V AC 230 V ¹⁾ DC 205 V ¹⁾				
Speed and angle encoder					
	Resolver SinCos single-turn/multi-turn Incremental encoder				
Cooling					
Without blower	Naturally ventilated				
Axial blower, 1 phase	230 V; 50 Hz				
Thermal sensor					
Thermal detector	KTY				
Motor connection: plug connector					
	Power + brake Encoder + thermal sensor Blower				
Motor connection: terminal box					
	Power + brake Encoder + thermal sensor	Power + brake Encoder + thermal sensor + blower			
Motor connection: Terminal box + plug connector					
Terminal box	Power + brake Encoder + thermal sensor				
Plug connector	Blower				
Shaft bearings					
Bearing type	Deep-groove ball bearing with high-temperature resistant grease, sealing disc or cover plate				
Position of the locating bearing	Drive end Standard motors (B3, B5, B14): side B Motors for gearbox direct mounting: side A				
Installation of the locating bearing					
Colour	RAL9005M				

¹⁾ Not possible for UR version.

MCA asynchronous servo motors

General information



Functions and features

	MCA20	MCA21	MCA22	MCA26
Design				
	B3 B35-FF215 B35-FF265	B14-FT130 B5-FF215 B5-FF265	B3 B35-FF265	B3 B35-FF265 B35-FF350
Shaft end (with and without keyway)	38 x 80			55 x 110
A end shield	Oil-tight Not oil-tight			
Brake				
Spring-applied brake	DC 24 V AC 230 V ¹⁾			DC 24 V AC 230 V ¹⁾
Permanent magnetic brake		DC 24 V AC 230 V ¹⁾ DC 205 V ¹⁾		
Speed and angle encoder	Resolver SinCos single-turn/multi-turn Incremental encoder			
Cooling				
Without blower		Naturally ventilated		
Axial blower, 1 phase	230 V; 50 Hz 230 V; 60 Hz	230 V; 50 Hz		230 V; 50 Hz 230 V; 60 Hz
Thermal sensor				
Thermal detector	KTY			
Motor connection: plug connector				
	Power + brake Encoder + thermal sensor Blower			
Motor connection: terminal box				
		Power + brake Encoder + thermal sensor + blower		
Motor connection: Terminal box + plug connector				
Terminal box	Power + brake	Power + brake Encoder + thermal sensor		Power + brake
Plug connector	Encoder + thermal sensor Blower	Blower		Encoder + thermal sensor Blower
Shaft bearings				
Bearing type	Deep-groove ball bearing with high-temperature resistant grease, sealing disc or cover plate			
Position of the locating bearing	Non-drive end	Drive end Standard motors (B3, B5, B14): side B Motors for gearbox dir- ect mounting: side A		Non-drive end
Installation of the locating bearing	insulation			insulation
Colour	RAL9005M			

¹⁾ Not possible for UR version.

MCA asynchronous servo motors



General information

Dimensioning

Speed-dependent safety functions

Single encoder concepts with resolvers

Servo motors can perform speed-dependent safety functions for safe speed and / or safe relative position monitoring in a drive system with the Servo Drives 9400. The SM301 safety module, which can be integrated in the Servo Drives 9400, is used to implement these functions. When planning systems/installations of this kind, the following must always be observed:

When using just one single feedback system in the environment of these safety applications, the applicable safety engineering standard IEC 61800-5-2 [Adjustable speed electrical power drive systems - Part: 5-2: Safety requirements - Functional] stipulates special requirements for the connection between feedback system and motor shaft. This is due to the fact that two-channel safety systems at this point in the mechanical system are actually designed as single-channel systems. If this mechanical connection is designed with considerable overdimensioning, the standard permits exclusion of the fault "encoder-shaft breakage" or "encoder-shaft slip". As such, acceleration limit values must not be exceeded for the individual drive solutions. You can find the limit values in the corresponding feedback data of the individual motor ranges.

Speed-dependent safety functions in connection with the SM301 safety module

For the following speed-dependent safety functions, the motor-feedback system combinations listed in the following table are available:

- Safe stop 1 (SS1)
- Safe operational stop (SOS)
- Safely Limited Speed (SLS)
- Safe Maximum Speed (SMS)
- Safe direction (SDI)
- Operation mode selector (OMS) with confirmation (ES)
- Safe speed monitor (SSM)
- Safely limited increment (SLI).

Encoder type	Encoder type	Product key	Feedback Design	Safe speed monitoring
SinCos incremental	Single-turn	IG1024-5V-V3	2-encoder concept	PL e/SIL 3 up to PL e / SIL 3
Resolver		RV03		

MCA asynchronous servo motors

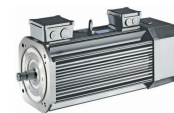

General information

Dimensioning

Cooling effect of mounting flange

Mounting on a thermally conducting / insulating plate or machine chassis has an influence on heating up the motor, particularly when using naturally ventilated motors.

The motor rating data specified in the catalogue applies when mounting on a steel plate with free convection with the following dimensions:

- MCA10 / 13: 270 x 270 mm
- MCA14 / 17: 330 x 330 mm
- MCA19 to 26: 450 x 450 mm

Vibrational severity

		MCA10	MCA13	MCA14	MCA17	MCA19	MCA20	MCA21	MCA22	MCA26
Vibrational severity										
IEC/EN 60034-14		A			B		A	B		A
Maximum r.m.s. value of the vibration velocity ¹⁾	[mm/s]	1.60			0.70		1.60	0.70		1.60

¹⁾ Free suspension

- ▶ at n = 600 to 3,600 rpm



Dimensioning

Concentricity and axial run-out of the mounting flanges and smooth running of the shaft ends

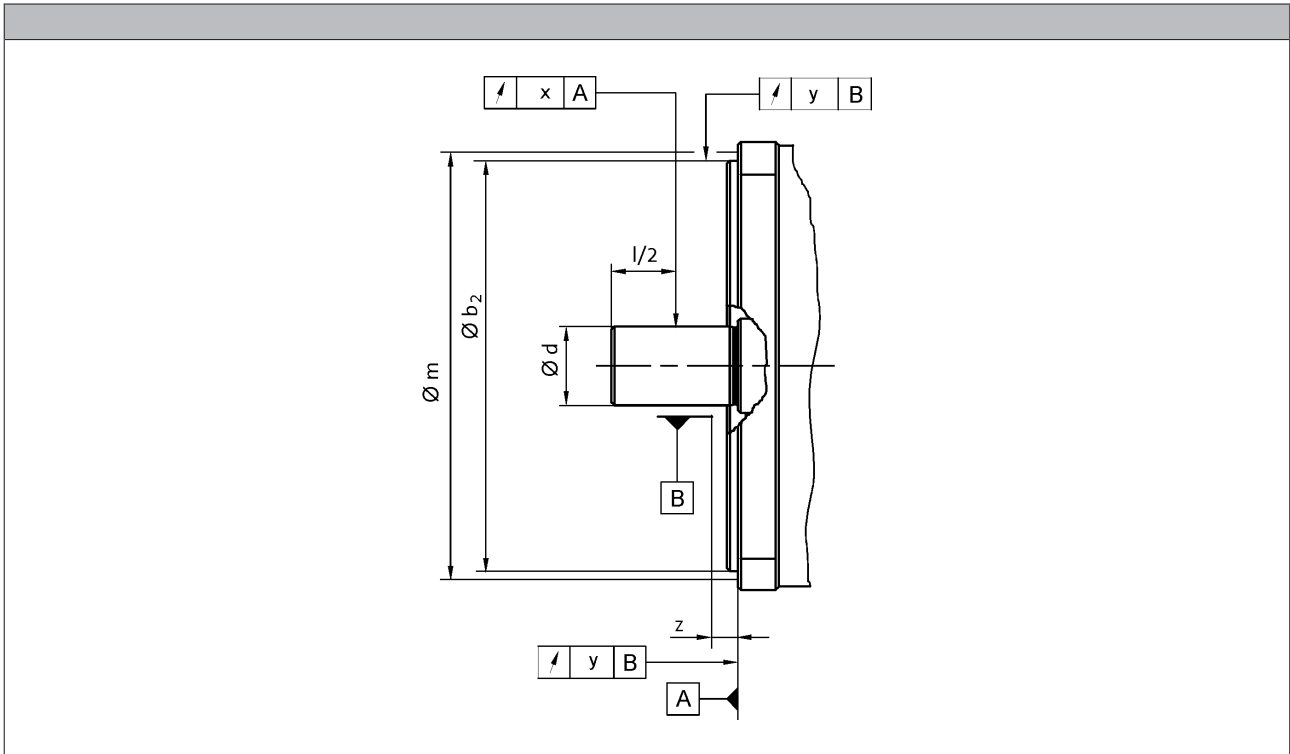

				MCA10		MCA13		MCA14		MCA17		MCA19	
Flange size				FF100	FT85	FF130	FT130	FF165	FT130	FF165	FT130	FF215	FT130
Dimensions													
	b_2	j6	[mm]	80	70	110	130	110	130	110	180	110	
	b_2	h6	[mm]										
	d	k6	[mm]	14		19		24				28	
	d	m6	[mm]										
Distance													
Measuring diameter	m		[mm]	113	98.0	149	188	149	188	149	239	149	
Dial gauge holder for flange check	z	+/- 1	[mm]	10.0									
Concentricity													
IEC 60072				Normal class				Precision class					
Value	y		[mm]	0.080		0.10		0.050					
Linear movement													
IEC 60072				Normal class				Precision class					
Value	y		[mm]	0.080		0.10		0.050					
Smooth running													
IEC 60072				Normal class				Precision class					
Value	x		[mm]	0.035		0.040		0.021					

- Limit values for checking the smooth running of the shaft ends as well as the concentricity and axial run-out of the mounting flange to IEC 60072

MCA asynchronous servo motors

General information



Dimensioning

Concentricity and axial run-out of the mounting flanges and smooth running of the shaft ends

				MCA20		MCA21			MCA22	MCA26	
Flange size				FF215	FF265	FF215	FF265	FT130	FF265	FF350	
Dimensions											
	b ₂	j6	[mm]	180	230	180	230	110	230		
	b ₂	h6	[mm]							300	
	d	k6	[mm]	38							
	d	m6	[mm]							55	
Distance											
Measuring diameter	m		[mm]	239	289	239	289	149	289		384
Dial gauge holder for flange check	z	+/- 1	[mm]	10.0							
Concentricity											
IEC 60072				Normal class		Precision class			Normal class		
Value	y		[mm]	0.10		0.050			0.10		
Linear movement											
IEC 60072				Normal class		Precision class			Normal class		
Value	y		[mm]	0.10		0.050			0.10		
Smooth running											
IEC 60072				Normal class		Precision class			Normal class		
Value	x		[mm]	0.050		0.060			0.050	0.060	

- Limit values for checking the smooth running of the shaft ends as well as the concentricity and axial run-out of the mounting flange to IEC 60072



Dimensioning

Notes on the selection tables

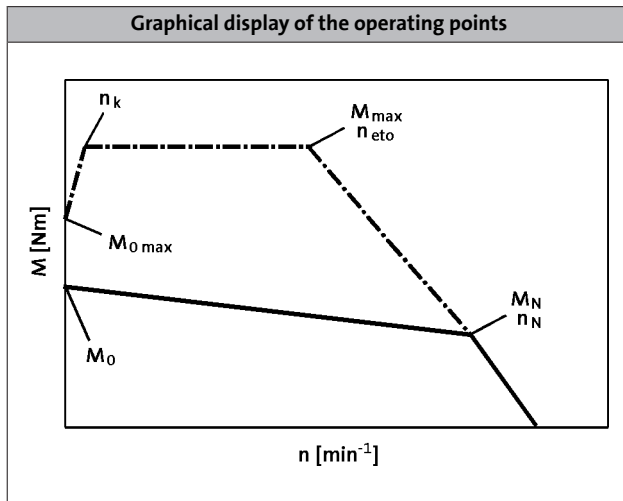

Please note:

- With an active load (e.g. vertical drive axes, hoists, test benches, unwinders), $M_{0\max}$ must be taken into account
- With a passive load (e.g. horizontal drive axes), M_{\max} can generally be used
- At speeds $< n_k$, the inverter-specific torque $M_{0\max}$ that can be achieved is lower than M_{\max}
- On the servo inverters, the switching frequency-dependent overload capacity has been taken into account in the factory settings. For further information, please refer to the Servo-Inverters catalogue.

	n_k [r/min]
MCA	150
MQA	

Further selection tables with different switching frequencies are available with the following codes:

- DS_ZT_MCS_0001
- DS_ZT_MCA_0001
- DS_ZT_MDSKS_0001
- DS_ZT_MDFKS_0001

Simply enter this code (e.g. DS_ZT_MCS_0001) as a search string at www.lenze.de/dsc and you will be given the information immediately in the form of a PDF format.



Dimensioning

Notes on the torque characteristics

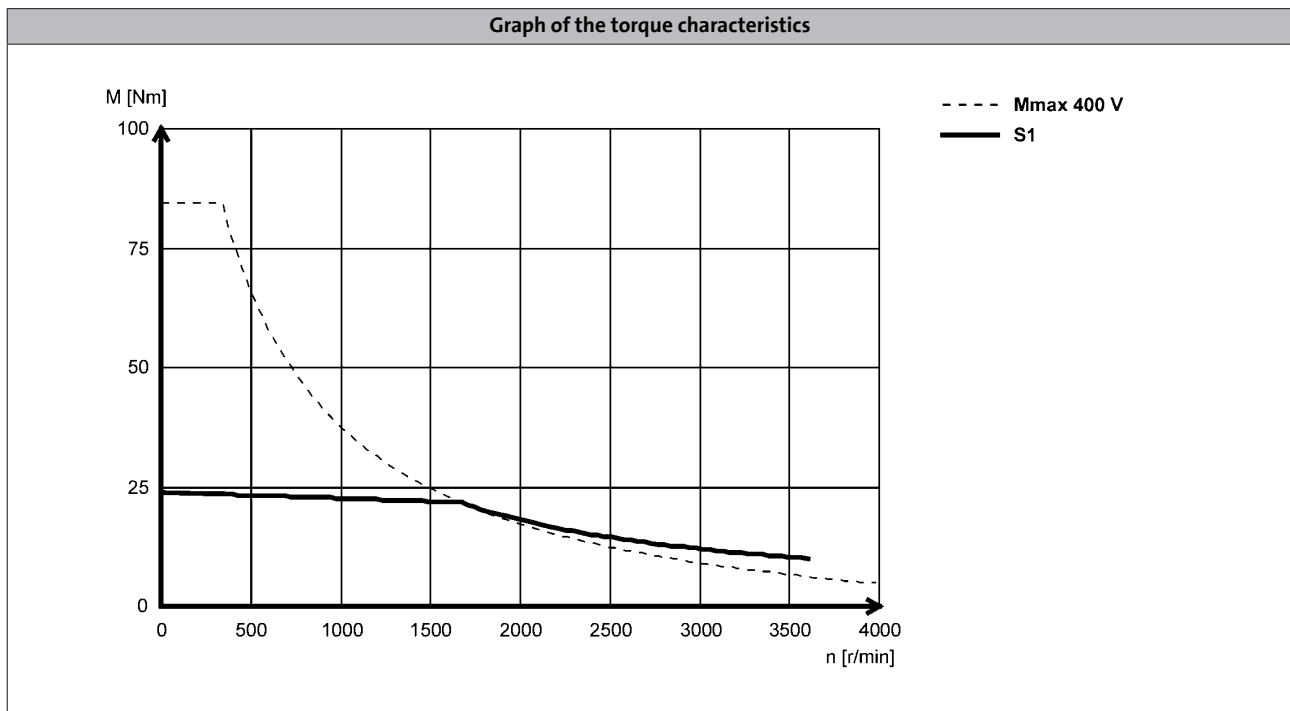

With asynchronous servo motors, two characteristics are shown in each case. The characteristics for continuous operation (S1) show the speed-dependent constant torque of the motor when operating with a servo inverter that itself is operated at a constant switching frequency. The limit torque characteristics correspond to those that come about during operation of the motor with the largest possible 9400 Servo Drive in each case (see selection tables). The servo inverter is set to a variable switching frequency here.

Characteristics in the Internet

You can find the torque characteristic for inverter-motor combinations on the Internet at www.lenze.de/dsc. This lists all useful combinations with the servo inverters 9400, 9300, ECS and Inverter Drives 8400 TopLine. These characteristics are each determined using the factory default settings of the inverters:

- 9400 with variable switching frequency.
This means that up to 6-fold overcurrent can be applied in borderline cases.
- 9300 and ECS with fixed switching frequency.
- 8400 TopLine with variable switching frequency.

The continuous operation characteristics (S1) show the inverter-independent motor rating values

6.11

Further information on the terms switching frequency and factory default settings can be found in the operating manual of the respective servo inverter.

MCA asynchronous servo motors

General information



Dimensioning

Influence of ambient temperature and site altitude

The information relating to the servo motors in the tables and graphs is valid for a maximum ambient temperature (T_{opr}) of 40 °C and a site altitude (H) up to 1000 m above sea level. The torque correction factor (k_{M1}) shall be applied to the S1 torque characteristic ($M_0...M_N$) in the event of differing installation conditions.

- The maximum permissible ambient temperature (T_{opr}) for servo motors with blowers is 40 °C

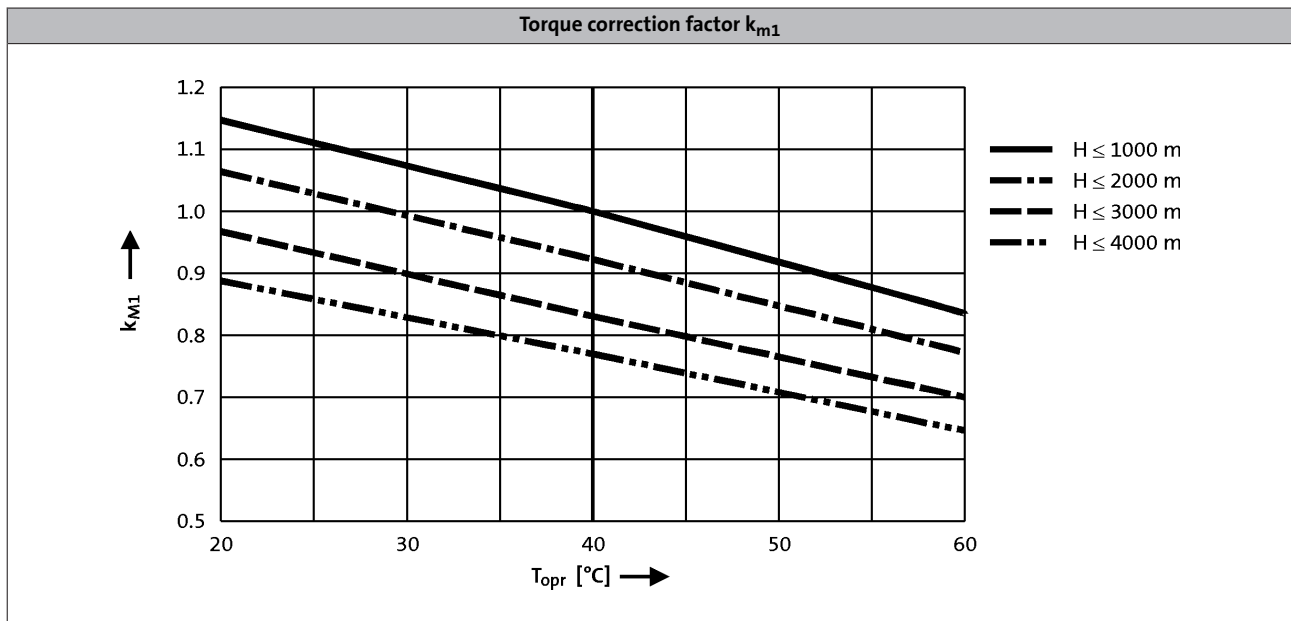

MCA asynchronous servo motors

General information



MCA asynchronous servo motors

Technical data



Standards and operating conditions

			MCA	
Cooling type			Naturally ventilated	Blower
Enclosure				
EN 60529			IP54 IP65	IP54 IP23s ²⁾
Temperature class			F	
IEC/EN 60034-1; utilisation			H	
IEC/EN 60034-1; insulation system (enamel-insulated wire)				
Conformity			Low-Voltage Directive	
CE			2006/95/EC	
EAC			TP TC 004/2011 (TR C	
Approval			UkrSEPRO	
CSA			CSA 22.2 No. 100	
cURus ³⁾			UL 1004-1 UL 1004-6 Power Conversion Equipment (File-No. E210321)	
Max. voltage load			Pulse voltage limiting curve A	
IEC/TS 60034-25				
Smooth running			Precision class ¹⁾ Normal class	
IEC 60072				
Linear movement			Precision class ¹⁾ Normal class	
IEC 60072				
Concentricity			Precision class ¹⁾ Normal class	
IEC 60072				
Mechanical ambient conditions (vibration)			3M6 3M6	
IEC/EN 60721-3-3				
Min. ambient operating temperature				
Without brake	T _{opr,min}	[°C]	-20	-15
With brake	T _{opr,min}	[°C]	-10	
Max. ambient temperature for operation			40	
	T _{opr,max}	[°C]		
Max. surface temperature			140	
	T	[°C]	110	
Mechanical tolerance			b ₂ ≤ 230 mm = j6 b ₂ > 230 mm = h6	
Flange centring diameter				
Shaft diameter			d ≤ 50 mm = k6 d > 50 mm = m6	
Site altitude			4000	
Amsl	H _{max}	[m]		

¹⁾ MCA14, 17, 19 and 21.

²⁾ MCA20, 22 and 26.

³⁾ MCA20X29, MCA21X35 with circular connector for motor connection only
UR



Permissible radial and axial forces

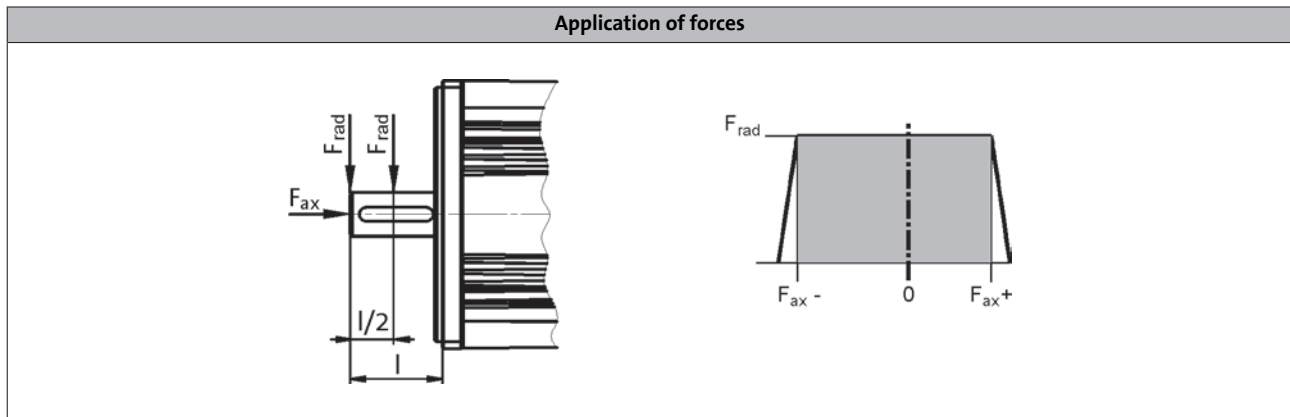

Application of force at l/2

	Bearing service life L_{10}														
	5000 h			10000 h			20000 h			30000 h			50000 h		
	F_{rad}	$F_{ax,-}$	$F_{ax,+}$	F_{rad}	$F_{ax,-}$	$F_{ax,+}$	F_{rad}	$F_{ax,-}$	$F_{ax,+}$	F_{rad}	$F_{ax,-}$	$F_{ax,+}$	F_{rad}	$F_{ax,-}$	$F_{ax,+}$
	[N]	[N]	[N]	[N]	[N]	[N]	[N]	[N]	[N]	[N]	[N]	[N]	[N]	[N]	[N]
MCA10	630	-130	320	500	-60	250	400	-30	210	330	-10	190	230	0	200
MCA13	850	-110	570	700	-10	450	470	0	450		0	450			
MCA14	1000	-140	500	780	-60	420	550	-30	380	400	-10	360	250	0	350
MCA17	1380	-180	790	1040	-70	680	660	-40	650	440	-20	630	280		610
MCA19	1880	-50	1530	1080	-30	1510	500	-100	1490	160	0	1470			
MCA20	3400	-1330	690	2500	-1020	380	1950	-780	140	1700	-690	40			
MCA21	3200	-260	1740	2360	-70	1550	1470	-20	1504	1030	0	1480			
MCA22	3600	-2370	1700	2800	-1740	1090	2200	-1280	640	1900	-1080	440	1600	-880	240
MCA26	6950	-2500	1580	5400	-1800	880	4300	-1300	380	3700	-1090	160			

Application of force at l

	Bearing service life L_{10}														
	5000 h			10000 h			20000 h			30000 h			50000 h		
	F_{rad}	$F_{ax,-}$	$F_{ax,+}$	F_{rad}	$F_{ax,-}$	$F_{ax,+}$	F_{rad}	$F_{ax,-}$	$F_{ax,+}$	F_{rad}	$F_{ax,-}$	$F_{ax,+}$	F_{rad}	$F_{ax,-}$	$F_{ax,+}$
	[N]	[N]	[N]	[N]	[N]	[N]	[N]	[N]	[N]	[N]	[N]	[N]	[N]	[N]	[N]
MCA10	590	-130	320	470	-60	250	370	-30	210	310	-10	190	220	0	200
MCA13	780	-110	570	640	-10	450	430	0	450	300	0	450			
MCA14	930	-140	500	710	-60	420	490	-30	380	370	-10	360	230	0	350
MCA17	1270	-180	790	960	-70	680	610	-40	650	400	-20	630	260		610
MCA19	1740	-50	1530	1000	-30	1510	420	-100	1490	140	0	1470			
MCA20	3150	-1170	530	2300	-920	280	1800	-710	70	1400	-650	0			
MCA21	2940	-260	1740	2160	-70	1550	1350	-20	1504	950	0	1480			
MCA22	3500	-2240	1600	2600	-1640	1100	2050	-1200	560	1800	-1020	380	1450	-850	200
MCA26	6400	-2080	1150	5000	-1600	680	4000	-1160	230	3400	-1090	50			

- The values for the bearing service life L_{10} relate to an average speed of 4000 r/min. For MCA20/22/26 the speed is 3000 r/min. Depending on the ambient temperatures, the service life of the bearings is also reduced by the grease lifetime.



Permissible radial and axial forces

- Reinforced bearings

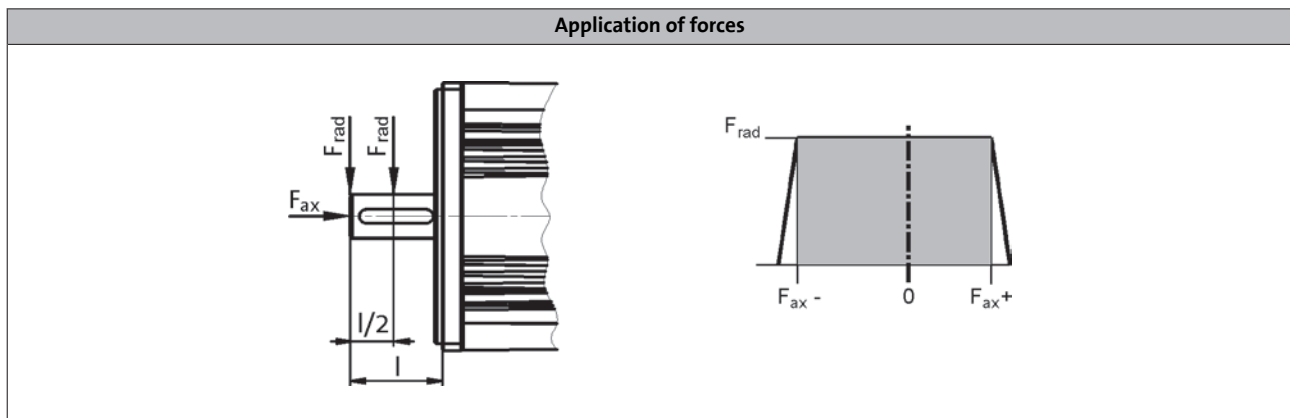

Application of force at $l/2$

	Bearing service life L_{10}														
	5000 h			10000 h			20000 h			30000 h			50000 h		
	F_{rad}	$F_{ax,-}$	$F_{ax,+}$	F_{rad}	$F_{ax,-}$	$F_{ax,+}$	F_{rad}	$F_{ax,-}$	$F_{ax,+}$	F_{rad}	$F_{ax,-}$	$F_{ax,+}$	F_{rad}	$F_{ax,-}$	$F_{ax,+}$
	[N]	[N]	[N]	[N]	[N]	[N]	[N]	[N]	[N]	[N]	[N]	[N]	[N]	[N]	[N]
MCA20	7100	-970	330	5100	-800	160	3900	-640	0						
MCA22	8500	-1850	1200	7000	-1400	760	5600	-1030	390	4350	-930	290	3200	-800	160
MCA26	10500	-2180	1250	8370	-1530	600	6670	-1130	200	5840	-960	30			

Application of force at l

	Bearing service life L_{10}														
	5000 h			10000 h			20000 h			30000 h			50000 h		
	F_{rad}	$F_{ax,-}$	$F_{ax,+}$	F_{rad}	$F_{ax,-}$	$F_{ax,+}$	F_{rad}	$F_{ax,-}$	$F_{ax,+}$	F_{rad}	$F_{ax,-}$	$F_{ax,+}$	F_{rad}	$F_{ax,-}$	$F_{ax,+}$
	[N]	[N]	[N]	[N]	[N]	[N]	[N]	[N]	[N]	[N]	[N]	[N]	[N]	[N]	[N]
MCA20	6350	-720	80	4100	-680	40	2800	-640	0						
MCA22	7000	-1750	1100	5500	-1300	660	4700	-920	280	3900	-820	180	3000	-700	60
MCA26	9600	-2200	1280	7700	-1280	360	6000	-960	30						

- The values for the bearing service life L_{10} refer to an average speed of 3000 r/min. Depending on the ambient temperatures, the service life of the bearings is also reduced by the grease life-time.

MCA asynchronous servo motors

Technical data



Rated data, non-ventilated

► The data applies to a mains connection voltage of 3 x 400 V.

	n_N [r/min]	M_0 [Nm]	M_N [Nm]	M_{max} [Nm]	P_N [kW]	I_0 [A]	I_N [A]	$U_{N, AC}$ [V]	f_N [Hz]	$J^{1)}$ [kgcm ²]	$\eta_{100\%}$ [%]
MCA10I40	3950	2.30	2.00	10.0	0.80	2.60	2.40	390	140	2.40	0.70
MCA13I41	4050	4.60	4.00	32.0	1.70	4.60	4.40	390	140	8.30	75.0
MCA14L20	2000	8.00	6.70	60.0	1.40	3.90	3.30	390	70	19.2	84.0
MCA14L41	4100	8.00	5.40	60.0	2.30	7.70	5.80	390	140	19.2	78.0
MCA17N23	2300	12.8	10.8	100	2.60	6.00	5.50	390	80	36.0	86.0
MCA17N41	4110	12.8	9.50	100	4.10	12.0	10.2	350	140	36.0	83.0
MCA19S23	2340	22.5	16.3	180	4.00	9.90	8.20	390	80	72.0	90.0
MCA19S42	4150	22.5	12.0	180	5.20	19.7	14.0	330	140	72.0	83.0
MCA21X25	2490	39.0	24.6	300	6.40	15.9	13.5	390	85	180	85.0
MCA21X42	4160	39.0	17.0	300	7.40	31.8	19.8	320	140	180	84.0

	R_1 [Ω]	$R_{UV\ 20\ ^\circ C}$ [Ω]	$R_{UV\ 150\ ^\circ C}$ [Ω]	R_2 [Ω]	$L_{1\sigma}$ [mH]	L [mH]	$L_{2\sigma}$ [mH]	$n_{max}^{2)}$ [r/min]	$m^{1)}$ [kg]
MCA10I40	4.70	9.40	12.7	5.20	9.80	169	10.0	8000	6.40
MCA13I41	1.70	3.40	4.60	1.41	5.40	92.6	4.90		10.4
MCA14L20	3.00	6.00	8.10	3.13	10.0	269	10.0		15.1
MCA14L41	0.75	1.50	2.00	0.78	2.50	65.8	2.50		22.9
MCA17N23	1.52	3.04	4.10	1.37	6.20	176	6.80		
MCA17N41	0.38	0.76	1.00	0.34	1.50	43.4	1.70		44.7
MCA19S23	0.69	1.38	1.90	0.62	3.20	111	3.90		
MCA19S42	0.18	0.35	0.50	0.15	0.80	28.0	1.00		60.0
MCA21X25	0.36	0.72	1.00	0.36	2.30	78.1	2.80		
MCA21X42	0.090	0.18	0.20	0.090	0.60	19.5	0.70		

¹⁾ Without brake.

²⁾ Mechanically permissible maximum speed.

The data in the R_1 , $L_{1\sigma}$, L , R_2' and $L_{2\sigma}'$ columns is based on a single-phase equivalent circuit diagram at 20°C.

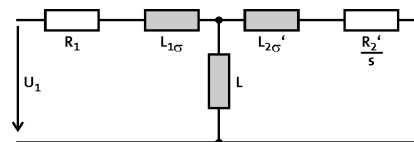

MCA asynchronous servo motors

Technical data



Rated data, IP54 forced ventilated

► The data applies to a mains connection voltage of 3 x 400 V.

	n_N	M_0	M_N	M_{max}	P_N	I_0	I_N	$U_{N, AC}$	f_N	$J^{1)}$	$\eta_{100\%}$
	[r/min]	[Nm]	[Nm]	[Nm]	[kW]	[A]	[A]	[V]	[Hz]	[kgcm ²]	[%]
MCA13I34	3410	7.00	6.30	32.0	2.20	6.30	6.00	390	120	8.30	72.0
MCA14L16	1635	13.5	12.0	60.0	2.10	5.30	4.80	390	60	19.2	80.0
MCA14L35	3455	13.5	10.8	60.0	3.90	10.5	9.10	390	120	19.2	79.0
MCA17N17	1680	23.9	21.5	100	3.80	9.10	8.50	390	60	36.0	83.0
MCA17N35	3480	23.9	19.0	100	6.90	18.1	15.8	390	120	36.0	81.0
MCA19S17	1700	40.0	36.3	180	6.40	15.4	13.9	390	60	72.0	82.0
MCA19S35	3510	40.0	36.0	180	13.2	30.8	28.7	390	120	72.0	85.0
MCA21X17	1710	75.0	61.4	300	11.0	25.8	22.5	390	60	180	85.0
MCA21X35	3520	75.0	55.0	300	20.3	49.5	42.5	390	120	180	88.0
MCA22P08...5F□□	760	120	110	500	8.75	23.4	22.1	345	28	487	80.0
MCA22P14...5F□□	1425	120	107	500	16.0	40.5	37.7	350	50	487	87.0
MCA22P17...5F□□	1670	120	106	500	18.5	46.7	42.7	360	58	487	88.0
MCA22P29...5F□□	2935	120	100	500	30.7	80.9	72.1	360	100	487	87.0
MCA26T05...5F□□	550	220	216	1100	12.4	35.4	34.9	350	19	1335	83.0
MCA26T10...5F□□	1030	220	210	1100	22.7	62.9	61.5	350	36	1335	88.0
MCA26T12...5F□□	1200	220	207	1100	26.0	78.4	75.1	350	41	1335	87.0
MCA26T22...5F□□	2235	220	195	1100	45.6	125	113	340	76	1335	92.0

	R_1	$R_{UV\ 20^\circ C}$	$R_{UV\ 150^\circ C}$	R_2	$L_{1\sigma}$	L	$L_{2\sigma}$	$n_{max}^{2)}$	$m^{1)}$	
	[Ω]	[Ω]	[Ω]	[Ω]	[mH]	[mH]	[mH]	[r/min]	[kg]	
MCA13I34	1.70	3.40	4.60	1.41	4.90	76.7	4.40	8000	12.0	
MCA14L16	3.00	6.00	8.10	3.13	9.50	224	9.30		16.9	
MCA14L35	0.75	1.50	2.00	0.78	2.40	56.7	2.30		25.5	
MCA17N17	1.52	3.04	4.10	1.37	5.60	144	6.00		48.2	
MCA17N35	0.38	0.76	1.00	0.34	1.40	36.9	1.50		63.5	
MCA19S17	0.69	1.38	1.90	0.62	2.60	80.9	3.10		6500	105
MCA19S35	0.18	0.35	0.50	0.15	0.70	20.3	0.80			
MCA21X17	0.36	0.72	1.00	0.36	2.10	68.9	2.60			
MCA21X35	0.090	0.18	0.20	0.090	0.50	16.8	0.60			
MCA22P08...5F□□	0.54	1.07	1.62	0.48	3.56	94.9	4.80			
MCA22P14...5F□□		0.36	0.54		3.60	94.2	4.85			
MCA22P17...5F□□	0.13	0.27	0.40	0.12	0.90	23.4	1.21			
MCA22P29...5F□□		0.080	0.12		22.9					
MCA26T05...5F□□	0.29	0.59	0.89	0.25	2.86	66.8	5.04			
MCA26T10...5F□□		0.20	0.30		2.93	69.2		5.12		
MCA26T12...5F□□	0.080	0.15	0.23	0.062	0.74	18.1	1.29			
MCA26T22...5F□□		0.050	0.075		0.78	19.8				

1) Without brake.

2) Mechanically permissible maximum speed.

The data in the R_1 , $L_{1\sigma}$, L , R_2' and $L_{2\sigma}'$ columns is based on a single-phase equivalent circuit diagram at 20°C.

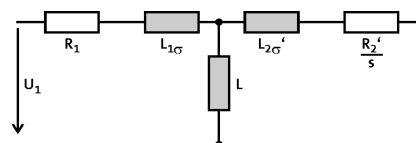

MCA asynchronous servo motors

Technical data



Rated data, IP23s forced ventilated

► The data applies to a mains connection voltage of 3 x 400 V.

	n_N [r/min]	M_0 [Nm]	M_N [Nm]	M_{max} [Nm]	P_N [kW]	I_0 [A]	I_N [A]	$U_{N, AC}$ [V]	f_N [Hz]	$J^{1)}$ [kgcm ²]	$\eta_{100\%}$ [%]
MCA20X14...2F□□	1420	68.0	61.0	250	9.07	26.0	23.0	350	50	171	82.0
MCA20X29...2F□□	2930	68.0	53.5	250	16.4	52.0	42.4	350	100	171	87.0
MCA22P08...2F□□	760	135	120	500	9.55	26.0	23.5	355	28	487	80.0
MCA22P14...2F□□	1425	135	115	500	17.2	45.1	40.0	360	50	487	86.0
MCA22P17...2F□□	1670	135	112	500	19.6	52.1	44.5	360	58	487	88.0
MCA22P29...2F□□	2935	135	110	500	33.8	90.2	77.8	360	100	487	89.0
MCA26T05...2F□□	550	290	280	1100	16.1	44.0	42.4	350	20	1335	81.0
MCA26T10...2F□□	1030	290	260	1100	28.0	78.0	69.6	350	36	1335	87.0
MCA26T12...2F□□	1200	290	255	1100	32.0	101	83.3	350	41	1335	87.0
MCA26T22...2F□□	2235	290	230	1100	53.8	160	127	340	76	1335	92.0

	R_1 [Ω]	$R_{UV\ 20\ ^\circ C}$ [Ω]	$R_{UV\ 150\ ^\circ C}$ [Ω]	R_2 [Ω]	$L_{1\sigma}$ [mH]	L [mH]	$L_{2\sigma}$ [mH]	$n_{max}^{2)}$ [r/min]	$m^{1)}$ [kg]
MCA20X14...2F□□	0.37	0.73	1.10	0.36	2.01	60.2	2.14	6500	64.0
MCA20X29...2F□□	0.090	0.18	0.28	0.090	0.50	14.3	0.54		
MCA22P08...2F□□	0.54	1.07	1.62	0.48	3.50	91.9	4.74		
MCA22P14...2F□□		0.36	0.54		3.55	90.9	4.79		
MCA22P17...2F□□	0.13	0.27	0.40	0.12	0.90	23.5	1.22		
MCA22P29...2F□□		0.080	0.12		22.9	1.21			
MCA26T05...2F□□	0.29	0.59	0.89	0.25	3.11	72.1	5.08	194	
MCA26T10...2F□□		0.20	0.30		3.17	71.4	5.14		
MCA26T12...2F□□	0.080	0.15	0.23	0.062	0.78	18.6	1.30		
MCA26T22...2F□□		0.050	0.077		20.2				

¹⁾ Without brake.

²⁾ Mechanically permissible maximum speed.

The data in the R_1 , $L_{1\sigma}$, L , R_2' and $L_{2\sigma}'$ columns is based on a single-phase equivalent circuit diagram at 20°C.

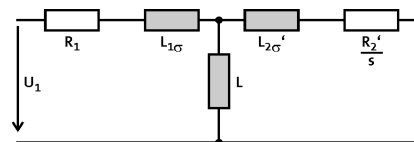

MCA asynchronous servo motors

Technical data



Selection tables, Servo Drives 9400 HighLine

Non-ventilated motors

- The data applies to a mains connection voltage of 3 x 400 V and an inverter switching frequency of 4 kHz.

					E94A□□	E0024	E0034	E0044	E0074	E0094	E0134	E0174	E0244	E0324
					I_N	1.9	3.1	5.0	8.8	11.7	16.3	20.6	29.4	38.4
					$I_{0,max}$	6.0	10.0	16.0	21.0	28.0	39.0	49.5	58.8	76.8
MCA	M_N	n_N	I_N	P_N	I_{max}	6.0	10.0	16.0	21.0	28.0	39.0	49.5	58.8	76.8
10I40	2.0	3950	2.4	0.80	M_0	1.1	2.3							
					M_N	1.0	2.0							
					$M_{0,max}$	6.9	10.0							
					M_{max}	6.9	10.0							
					η_{eto}	-	-							
13I41	4.0	4050	4.4	1.70	M_0			4.6	4.6					
					M_N			4.0	4.0					
					$M_{0,max}$			18.9	20.8					
					M_{max}			18.9	20.8					
					η_{eto}			-	-					
14L20	6.7	2000	3.3	1.40	M_0		5.1	8.0						
					M_N		4.4	6.7						
					$M_{0,max}$		25.0	42.8						
					M_{max}		25.0	42.8						
					η_{eto}		-	-						
14L41	5.4	4100	5.8	2.30	M_0			3.5	8.0	8.0				
					M_N			3.5	5.4	5.4				
					$M_{0,max}$			21.5	27.0	31.3				
					M_{max}			21.5	27.0	31.3				
					η_{eto}			-	-	-				
17N23	10.8	2300	5.5	2.60	M_0			9.5	12.8					
					M_N			9.0	10.8					
					$M_{0,max}$			38.0	50.0					
					M_{max}			38.0	50.0					
					η_{eto}			-	-					
17N41	9.5	4110	10.2	4.10	M_0			7.1	11.5	12.8	12.8			
					M_N			6.7	9.5	9.5	9.5			
					$M_{0,max}$			24.0	33.3	45.8	49.9			
					M_{max}			24.0	33.3	45.8	49.9			
					η_{eto}			-	-	-	-			
19S23	16.3	2340	8.2	4.00	M_0			18.4	22.5	22.5				
					M_N			15.6	16.3	16.3				
					$M_{0,max}$			55.0	73.7	86.0				
					M_{max}			55.0	73.7	86.0				
					η_{eto}			-	-	-				
19S42	12.0	4150	14.0	5.20	M_0					15.0	22.5	22.5		
					M_N					12.0	12.0	12.0		
					$M_{0,max}$					48.8	62.0	70.0		
					M_{max}					48.8	62.0	70.0		
					η_{eto}					-	-	-		
21X25	24.6	2490	13.5	6.40	M_0					21.4	39.0	39.0	39.0	
					M_N					19.6	24.6	24.6	24.6	
					$M_{0,max}$					71.7	96.0	126.0	136.0	
					M_{max}					71.7	96.0	126.0	136.0	
					η_{eto}					-	-	-	-	

- $I...$ [A], $M...$ [Nm], $n...$ [r/min], $P...$ [kW]

MCA asynchronous servo motors

Technical data



Selection tables, Servo Drives 9400 HighLine

Non-ventilated motors

- The data applies to a mains connection voltage of 3 x 400 V and an inverter switching frequency of 4 kHz.

					E94A□□	E0024	E0034	E0044	E0074	E0094	E0134	E0174	E0244	E0324
					I_N	1.9	3.1	5.0	8.8	11.7	16.3	20.6	29.4	38.4
					$I_{0,max}$	6.0	10.0	16.0	21.0	28.0	39.0	49.5	58.8	76.8
MCA	M_N	n_N	I_N	P_N	I_{max}	6.0	10.0	16.0	21.0	28.0	39.0	49.5	58.8	76.8
21X42	17.0	4160	19.8	7.40	M_0								31.3	39.0
					M_N								17.0	17.0
					$M_{0,max}$								71.7	91.0
					M_{max}								71.7	91.0
					η_{eto}									-

- $I...$ [A], $M...$ [Nm], $n...$ [r/min], $P...$ [kW]

MCA asynchronous servo motors

Technical data



Selection tables, Servo Drives 9400 HighLine

Forced ventilated IP54 motors

- The data applies to a mains connection voltage of 3 x 400 V and an inverter switching frequency of 4 kHz.

					E94A□□	E0044	E0074	E0094	E0134	E0174	E0244	E0324	E0474	E0594	E0864	
					I_N	5.0	8.8	11.7	16.3	20.6	29.4	38.4	47.0	59.0	86.0	
					$I_{0,max}$	16.0	21.0	28.0	39.0	49.5	58.8	76.8	94.0	118.0	172.0	
MCA	M_N	n_N	I_N	P_N	I_{max}	16.0	21.0	28.0	39.0	49.5	58.8	76.8	94.0	118.0	172.0	
13I34	6.3	3410	6.0	2.20	M_0	4.6	7.0	7.0								
					M_N	4.4	6.3	6.3								
					$M_{0,max}$	20.8	26.0	29.2								
					M_{max}	20.8	26.0	29.2								
					η_{eto}	-	-	-								
14L16	12.0	1635	4.8	2.10	M_0	12.0	13.5									
					M_N	12.0	12.0									
					$M_{0,max}$	45.4	52.6									
					M_{max}	45.4	52.6									
					η_{eto}	-	-									
14L35	10.8	3455	9.1	3.90	M_0		10.1	13.5	13.5							
					M_N		9.7	10.8	10.8							
					$M_{0,max}$		32.4	46.0	60.0							
					M_{max}		32.4	46.0	60.0							
					η_{eto}		-	-	-							
17N17	21.5	1680	8.5	3.80	M_0		21.6	23.9	23.9							
					M_N		21.5	21.5	21.5							
					$M_{0,max}$		59.4	81.4	84.5							
					M_{max}		59.4	81.4	84.5							
					η_{eto}		-	-	-							
17N35	19.0	3480	15.8	6.90	M_0				19.4	23.9	23.9					
					M_N				19.0	19.0	19.0					
					$M_{0,max}$				59.2	75.0	90.0					
					M_{max}				59.2	75.0	90.0					
					η_{eto}				-	-	-					
19S17	36.3	1700	13.9	6.40	M_0				40.0	40.0	40.0					
					M_N				36.3	36.3	36.3					
					$M_{0,max}$				105.0	133.0	148.0					
					M_{max}				105.0	133.0	148.0					
					η_{eto}				-	-	-					
19S35	36.0	3510	28.7	13.20	M_0					36.9	40.0	40.0	40.0			
					M_N					36.0	36.0	36.0	36.0			
					$M_{0,max}$					82.0	112.0	132.0	160.0			
					M_{max}					82.0	112.0	132.0	160.0			
					η_{eto}					-	-	-	-			
21X17	61.4	1710	22.5	11.00	M_0				54.4	75.0	75.0	75.0				
					M_N				50.4	61.4	61.4	61.4				
					$M_{0,max}$				134.0	158.0	215.0	246.0				
					M_{max}				134.0	158.0	215.0	246.0				
					η_{eto}				-	-	-	-				
21X35	55.0	3520	42.5	20.30	M_0								63.9	75.0	75.0	
					M_N									55.0	55.0	55.0
					$M_{0,max}$									134.0	167.0	232.0
					M_{max}									134.0	167.0	232.0
					η_{eto}									-	-	-

- $I...$ [A], $M...$ [Nm], $n...$ [r/min], $P...$ [kW]

MCA asynchronous servo motors

Technical data



Selection tables, Servo Drives 9400 HighLine

Forced ventilated IP54 motors

- The data applies to a mains connection voltage of 3 x 400 V and an inverter switching frequency of 8 kHz.

					E94A□□	E0174	E0244	E0324	E0474	E0594	E0864	E1044	E1454	E1724	E2024	E2454	
					I _N	16.5	23.5	32.0	41.0	41.0	73.0	78.0	102.0	120.0	131.0	160.0	
					I _{0,max}	49.5	58.8	76.8	94.0	118.0	172.0	208.0	261.0	310.0	364.0	441.0	
MCA	M _N	n _N	I _N	P _N	I _{max}	49.5	58.8	76.8	94.0	118.0	172.0	208.0	261.0	310.0	364.0	441.0	
22P08- ...5F□□	110.0	760	22.1	8.80	M ₀	64.0	110.0	120.0									
					M _N	64.0	110.0	110.0									
					M _{0,max}	261.0	313.0	402.0									
					M _{max}	261.0	313.0	402.0									
					η _{eto}	-	-	-									
22P14- ...5F□□	107.0	1425	37.7	16.00	M ₀			82.0	120.0	120.0							
					M _N			82.0	107.0	107.0							
					M _{0,max}			242.0	300.0	372.0							
					M _{max}			242.0	300.0	372.0							
					η _{eto}			-	-	-							
22P17- ...5F□□	105.0	1670	42.7	18.50	M ₀					99.0	120.0						
					M _N					99.0	106.0						
					M _{0,max}					325.0	463.0						
					M _{max}					325.0	463.0						
					η _{eto}					-	-						
22P29- ...5F□□	100.0	2935	72.1	30.70	M ₀							110.0	120.0	120.0			
					M _N							100.0	100.0	100.0			
					M _{0,max}							335.0	416.0	465.0			
					M _{max}							335.0	416.0	465.0			
					η _{eto}							-	-	-			
26T05- ...5F□□	216.0	550	34.9	12.40	M ₀			191.0	220.0	220.0	220.0						
					M _N			191.0	216.0	216.0	216.0						
					M _{0,max}			531.0	665.0	826.0	1010.0						
					M _{max}			531.0	665.0	826.0	1010.0						
					η _{eto}			-	-	-	-						
26T10- ...5F□□	210.0	1030	61.5	22.70	M ₀					77.0	220.0	220.0	220.0				
					M _N					77.0	210.0	210.0	210.0				
					M _{0,max}					472.0	713.0	855.0	1044.0				
					M _{max}					472.0	713.0	855.0	1044.0				
					η _{eto}					-	-	-	-				
26T12- ...5F□□	207.0	1200	75.1	26.00	M ₀						204.0	219.0	220.0	220.0			
					M _N						204.0	207.0	207.0	207.0			
					M _{0,max}						502.0	609.0	739.0	819.0			
					M _{max}						502.0	609.0	739.0	819.0			
					η _{eto}						-	-	-	-			
26T22- ...5F□□	195.0	2235	112.9	45.60	M ₀								154.0	211.0	220.0	220.0	
					M _N									154.0	195.0	195.0	195.0
					M _{0,max}									523.0	611.0	711.0	843.0
					M _{max}									523.0	611.0	711.0	843.0
					η _{eto}									-	-	-	-

- I... [A], M... [Nm], n... [r/min], P... [kW]
- If the motors are operated at a lower switching frequency, please contact your Lenze sales office!
- When operating at 4 kHz, the motor generates just 95 % of its rated torque with increased noise emissions.

MCA asynchronous servo motors

Technical data



Selection tables, Servo Drives 9400 HighLine

Forced ventilated IP23s motors

- The data applies to a mains connection voltage of 3 x 400 V and an inverter switching frequency of 8 kHz.

					E94A□□	E0174	E0244	E0324	E0474	E0594	E0864	E1044	E1454	E1724	E2024	E2454	E2924
					I _N	16.5	23.5	32.0	41.0	41.0	73.0	78.0	102.0	120.0	131.0	160.0	191.0
					I _{0,max}	49.5	58.8	76.8	94.0	118.0	172.0	208.0	261.0	310.0	364.0	441.0	526.0
MCA	M _N	n _N	I _N	P _N	I _{max}	49.5	58.8	76.8	94.0	118.0	172.0	208.0	261.0	310.0	364.0	441.0	526.0
20X14-...2F□□	61.0	1420	23.0	9.10	M ₀	32.5	66.0										
					M _N	32.5	61.0										
					M _{0,max}	154.2	190.0										
					M _{max}	154.2	190.0										
					η _{eto}	-	-										
20X29-...2F□□	53.5	2930	42.4	16.40	M ₀			28.0	51.6	51.6							
					M _N			28.0	51.6	51.6							
					M _{0,max}			116.0	148.2	192.8							
					M _{max}			116.0	148.2	192.8							
					η _{eto}			-	-	-							
22P08-...2F□□	120.0	760	23.5	9.60	M ₀		120.0	135.0									
					M _N		120.0	120.0									
					M _{0,max}		313.0	402.0									
					M _{max}		313.0	402.0									
					η _{eto}		-	-									
22P14-...2F□□	115.0	1425	40.0	17.20	M ₀				118.0	118.0							
					M _N				115.0	115.0							
					M _{0,max}				300.0	372.0							
					M _{max}				300.0	372.0							
					η _{eto}				-	-							
22P17-...2F□□	112.0	1670	44.5	19.60	M ₀					99.0	135.0						
					M _N					99.0	112.0						
					M _{0,max}					325.0	463.0						
					M _{max}					325.0	463.0						
					η _{eto}								-	-			
22P29-...2F□□	110.0	2935	77.8	33.80	M ₀							110.0	135.0	135.0			
					M _N							110.0	110.0	110.0			
					M _{0,max}							335.0	416.0	486.0			
					M _{max}							335.0	416.0	486.0			
					η _{eto}								-	-	-		
26T05-...2F□□	280.0	550	42.4	16.10	M ₀				268.0	268.0	290.0						
					M _N				268.0	268.0	280.0						
					M _{0,max}				665.0	826.0	1100.0						
					M _{max}				665.0	826.0	1100.0						
					η _{eto}								-	-	-		
26T10-...2F□□	260.0	1030	69.6	28.00	M ₀						270.0	290.0	290.0				
					M _N						260.0	260.0	260.0				
					M _{0,max}						713.0	855.0	1044.0				
					M _{max}						713.0	855.0	1044.0				
					η _{eto}									-	-	-	

- I... [A], M... [Nm], n... [r/min], P... [kW]
- If the motors are operated at a lower switching frequency, please contact your Lenze sales office!
- When operating at 4 kHz, the motor generates just 95 % of its rated torque with increased noise emissions.

MCA asynchronous servo motors

Technical data



Selection tables, Servo Drives 9400 HighLine

Forced ventilated IP23s motors

- ▶ The data applies to a mains connection voltage of 3 x 400 V and an inverter switching frequency of 8 kHz.

					E94A□□	E0174	E0244	E0324	E0474	E0594	E0864	E1044	E1454	E1724	E2024	E2454	E2924	
					I_N	16.5	23.5	32.0	41.0	41.0	73.0	78.0	102.0	120.0	131.0	160.0	191.0	
					$I_{0,max}$	49.5	58.8	76.8	94.0	118.0	172.0	208.0	261.0	310.0	364.0	441.0	526.0	
MCA	M_N	n_N	I_N	P_N	I_{max}	49.5	58.8	76.8	94.0	118.0	172.0	208.0	261.0	310.0	364.0	441.0	526.0	
26T12- ...2F□□	255.0	1200	83.3	32.00	M_0						204.0	219.0	290.0	290.0				
					M_N						204.0	219.0	255.0	255.0	255.0			
					$M_{0,max}$						502.0	609.0	739.0	840.0	896.0			
					M_{max}						502.0	609.0	739.0	840.0	896.0			
					η_{eto}											-	-	-
26T22- ...2F□□	230.0	2235	126.7	53.80	M_0									211.0	242.0	290.0	290.0	
					M_N									211.0	230.0	230.0	230.0	
					$M_{0,max}$									611.0	711.0	843.0	1001.0	
					M_{max}									611.0	711.0	843.0	1001.0	
					η_{eto}													-

- ▶ I... [A], M... [Nm], n... [r/min], P... [kW]
- ▶ If the motors are operated at a lower switching frequency, please contact your Lenze sales office!
- ▶ When operating at 4 kHz, the motor generates just 95 % of its rated torque with increased noise emissions.

MCA asynchronous servo motors

Technical data

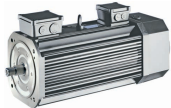

MCA asynchronous servo motors

Technical data



Selection tables, Inverter Drives 8400 TopLine

Non-ventilated motors

- The data applies to a mains connection voltage of 3 x 400 V and an inverter switching frequency of 8 kHz.

					E84AVTC	□5514	□7514	□1124	□1524	□2224	□3024	□4024	□5524	□7524	□1134	□1534	□1834				
					I_N	1.8	2.4	3.2	3.9	5.9	7.3	9.5	13.0	16.5	23.5	32.0	39.0				
					$I_{0,max}$	2.7	3.6	4.8	5.9	8.4	11.0	14.3	19.5	26.4	32.9	43.2	60.0				
MCA	M_N	n_N	I_N	P_N	I_{max}	3.6	4.8	6.4	7.8	11.8	14.6	19.0	26.0	33.0	47.0	64.0	78.0				
10I40	2.0	3950	2.4	0.80	M_0	-	2.3	2.3	2.3	2.3											
					M_N	-	1.9	1.9	1.9	1.9											
					$M_{0,max}$	4.2	5.8	8.0	9.8	10.0											
					M_{max}	4.2	5.8	8.0	9.8	10.0											
					η_{eto}	-	-	-	-	-											
13I41	4.0	4050	4.4	1.70	M_0			-	-	4.6	4.6	4.6									
					M_N			-	-	4.0	4.0	4.0									
					$M_{0,max}$			7.6	9.6	14.3	18.9	22.9									
					M_{max}			7.6	9.6	14.3	18.9	22.9									
					η_{eto}			-	-	-	-	-									
14L20	6.7	2000	3.3	1.40	M_0		-	-	8.0	8.0	8.0										
					M_N		-	-	6.7	6.7	6.7										
					$M_{0,max}$		11.6	16.2	20.1	29.4	34.7										
					M_{max}		11.6	16.2	20.1	29.4	34.7										
					η_{eto}		-	-	-	-	-										
14L41	5.4	4100	5.8	2.30	M_0					-	8.0	8.0	8.0								
					M_N					-	5.4	5.4	5.4								
					$M_{0,max}$					14.1	19.0	25.1	31.0								
					M_{max}					14.1	19.0	25.1	31.0								
					η_{eto}					-	-	-	-								
17N23	10.8	2300	5.5	2.60	M_0				-	12.8	12.8	12.8	12.8								
					M_N				-	10.8	10.8	10.8	10.8								
					$M_{0,max}$				17.1	25.3	33.3	43.8	51.1								
					M_{max}				17.1	25.3	33.3	43.8	51.1								
					η_{eto}				-	-	-	-	-								
17N41	9.5	4110	10.2	4.10	M_0						-	-	12.8	12.8	12.8						
					M_N						-	-	9.5	9.5	9.5						
					$M_{0,max}$						16.5	22.3	31.1	39.9	49.5						
					M_{max}						16.5	22.3	31.1	39.9	49.5						
					η_{eto}						-	-	-	-	-						
19S23	16.3	2340	8.2	4.00	M_0						-	22.5	22.5	22.5							
					M_N					-	16.3	16.3	16.3								
					$M_{0,max}$					32.8	43.6	60.9	77.5								
					M_{max}					32.8	43.7	61.0	77.5								
					η_{eto}					-	-	-	-								
19S42	12.0	4150	14.0	5.20	M_0								-	22.5	22.5	22.5					
					M_N								-	12.0	12.0	12.0					
					$M_{0,max}$								28.5	37.0	53.7	64.7					
					M_{max}								28.5	37.0	53.8	64.7					
					η_{eto}								-	-	-	-					
21X25	24.6	2490	13.5	6.40	M_0								-	-	39.0	39.0	39.0				
					M_N								-	-	24.5	24.5	24.5				
					$M_{0,max}$								33.6	46.7	59.3	85.9	97.3				
					M_{max}								33.6	46.7	59.3	85.9	97.6				
					η_{eto}								-	-	-	-					

- $I...$ [A], $M...$ [Nm], $n...$ [r/min], $P...$ [kW]

MCA asynchronous servo motors

Technical data



Selection tables, Inverter Drives 8400 TopLine

Non-ventilated motors

- The data applies to a mains connection voltage of 3 x 400 V and an inverter switching frequency of 8 kHz.

					E84AVTC	□5514	□7514	□1124	□1524	□2224	□3024	□4024	□5524	□7524	□1134	□1534	□1834	
					I_N	1.8	2.4	3.2	3.9	5.9	7.3	9.5	13.0	16.5	23.5	32.0	39.0	
					$I_{0,max}$	2.7	3.6	4.8	5.9	8.4	11.0	14.3	19.5	26.4	32.9	43.2	60.0	
MCA	M_N	n_N	I_N	P_N	I_{max}	3.6	4.8	6.4	7.8	11.8	14.6	19.0	26.0	33.0	47.0	64.0	78.0	
21X42	17.0	4160	19.8	7.40	M_0									-	39.0	39.0	39.0	
					M_N									-	17.0	17.0	17.0	
					$M_{0,max}$										35.3	52.2	72.1	88.5
					M_{max}										35.3	52.2	72.1	88.5
					η_{eto}													-

- I_N [A], M_N [Nm], n_N [r/min], P_N [kW]

MCA asynchronous servo motors

Technical data



Selection tables, Inverter Drives 8400 TopLine

Forced ventilated IP54 motors

- The data applies to a mains connection voltage of 3 x 400 V and an inverter switching frequency of 8 kHz.

					E84AVTC	□1524	□2224	□3024	□4024	□5524	□7524
					I_N	3.9	5.9	7.3	9.5	13.0	16.5
					$I_{0,max}$	5.9	8.4	11.0	14.3	19.5	26.4
MCA	M_N	n_N	I_N	P_N	I_{max}	7.8	11.8	14.6	19.0	26.0	33.0
13I34	6.3	3410	6.0	2.20	M_0	-	-	7.0	7.0	7.0	-
					M_N	-	-	6.2	6.2	6.2	-
					$M_{0,max}$	-	16.0	21.4	28.2	32.0	-
					M_{max}	-	16.0	21.4	28.2	32.0	-
					η_{eto}	-	-	-	-	-	-
14L16	12.0	1635	4.8	2.10	M_0	-	13.5	13.5	13.5	-	-
					M_N	-	12.3	12.3	12.3	-	-
					$M_{0,max}$	23.4	34.7	45.5	50.8	-	-
					M_{max}	23.4	34.7	45.5	50.8	-	-
					η_{eto}	-	-	-	-	-	-
14L35	10.8	3455	9.1	3.90	M_0	-	-	-	13.5	13.5	13.5
					M_N	-	-	-	10.8	10.8	10.8
					$M_{0,max}$	-	-	21.1	28.4	39.8	51.1
					M_{max}	-	-	21.1	28.4	39.8	51.1
					η_{eto}	-	-	-	-	-	-
17N17	21.5	1680	8.5	3.80	M_0	-	-	-	23.9	23.9	23.9
					M_N	-	-	-	21.6	21.6	21.6
					$M_{0,max}$	-	-	42.1	55.9	77.5	93.3
					M_{max}	-	-	42.2	56.0	77.5	93.3
					η_{eto}	-	-	-	-	-	-
17N35	19.0	3480	15.8	6.90	M_0	-	-	-	-	-	23.9
					M_N	-	-	-	-	-	18.9
					$M_{0,max}$	-	-	-	-	38.0	49.5
					M_{max}	-	-	-	-	38.0	49.5
					η_{eto}	-	-	-	-	-	-
19S17	36.3	1700	13.9	6.40	M_0	-	-	-	-	-	40.0
					M_N	-	-	-	-	-	36.0
					$M_{0,max}$	-	-	-	-	71.6	94.7
					M_{max}	-	-	-	-	71.6	94.7
					η_{eto}	-	-	-	-	-	-
19S35	36.0	3510	28.7	13.20	M_0	-	-	-	-	-	-
					M_N	-	-	-	-	-	-
					$M_{0,max}$	-	-	-	-	-	-
					M_{max}	-	-	-	-	-	-
					η_{eto}	-	-	-	-	-	-
21X17	61.4	1710	22.5	11.00	M_0	-	-	-	-	-	-
					M_N	-	-	-	-	-	-
					$M_{0,max}$	-	-	-	-	-	99.0
					M_{max}	-	-	-	-	-	99.0
					η_{eto}	-	-	-	-	-	-
21X35	55.0	3520	42.5	20.30	M_0	-	-	-	-	-	-
					M_N	-	-	-	-	-	-
					$M_{0,max}$	-	-	-	-	-	-
					M_{max}	-	-	-	-	-	-
					η_{eto}	-	-	-	-	-	-

- $I...$ [A], $M...$ [Nm], $n...$ [r/min], $P...$ [kW]

MCA asynchronous servo motors

Technical data



Selection tables, Inverter Drives 8400 TopLine

Forced ventilated IP54 motors

- The data applies to a mains connection voltage of 3 x 400 V and an inverter switching frequency of 8 kHz.

□1134	□1534	□1834	□2234	□3034	□3734	□4534	E84AVTC							
23.5	32.0	39.0	47.0	61.0	76.0	89.0	I_N	2.20	6.0	3410	6.3	13134		
32.9	43.2	60.0	70.5	91.5	114.0	133.5	$I_{0,max}$							
47.0	64.0	78.0	94.0	122.0	152.0	178.0	I_{max}							
							M_0							
							M_N							
							$M_{0,max}$	2.10	4.8	1635	12.0	14L16		
							M_{max}							
							n_{eto}							
							M_0							
							M_N							
13.5							$M_{0,max}$	3.90	9.1	3455	10.8	14L35		
10.8							M_{max}							
56.5							n_{eto}							
56.6							M_0							
-							M_N							
							$M_{0,max}$	3.80	8.5	1680	21.5	17N17		
							M_{max}							
							n_{eto}							
							M_0							
							M_N							
23.9	23.9						$M_{0,max}$	6.90	15.8	3480	19.0	17N35		
18.9	18.9						M_{max}							
72.5	97.8						n_{eto}							
72.5	97.8						M_0							
-	-						M_N							
40.0	40.0						$M_{0,max}$	6.40	13.9	1700	36.3	19S17		
36.0	36.0						M_{max}							
138.9	165.2						n_{eto}							
139.0	165.3						M_0							
-	-						M_N							
-	40.0	40.0	40.0	40.0			$M_{0,max}$	13.20	28.7	3510	36.0	19S35		
-	35.9	35.9	35.9	35.9			M_{max}							
55.1	78.8	97.8	112.8	146.2			n_{eto}							
55.1	78.8	97.8	112.9	146.2			M_0							
-	-	-	-	-			M_N							
75.0	75.0	75.0	75.0				$M_{0,max}$	11.00	22.5	1710	61.4	21X17		
61.4	61.4	61.4	61.4				M_{max}							
143.7	198.5	242.2	277.2				n_{eto}							
144.0	198.7	242.3	277.2				M_0							
-	-	-	-				M_N							
-	-	-	75.0	75.0	75.0	75.0	$M_{0,max}$	20.30	42.5	3520	55.0	21X35		
-	-	-	55.1	55.1	55.1	55.1	M_{max}							
	97.5	120.6	138.5	177.5	216.7	267.8	n_{eto}							
	97.5	120.6	138.6	178.0	217.5	269.8	M_0							
	-	-	-	-	-	-	M_N							

- $I...$ [A], $M...$ [Nm], $n...$ [r/min], $P...$ [kW]

MCA asynchronous servo motors

Technical data



Selection tables, Inverter Drives 8400 TopLine

Forced ventilated IP54 motors

- The data applies to a mains connection voltage of 3 x 400 V and an inverter switching frequency of 8 kHz.

					E84AVTC	□7524	□1134	□1534	□1834	□2234	□3034	□3734	□4534	
					I_N	16.5	23.5	32.0	39.0	47.0	61.0	76.0	89.0	
					$I_{0,max}$	26.4	32.9	43.2	60.0	70.5	91.5	114.0	133.5	
MCA	M_N	n_N	I_N	P_N	I_{max}	33.0	47.0	64.0	78.0	94.0	122.0	152.0	178.0	
22P08- ...5F□□	110.0	760	22.1	8.80	M_0	-	120.0	120.0	120.0	120.0				
					M_N	-	110.6	110.6	110.6	110.6				
					$M_{0,max}$	157.8	233.4	323.3	396.6	394.3				
					M_{max}	157.8	233.5	323.3	396.6	394.3				
					η_{eto}	-	-	-	-	-				
22P14- ...5F□□	107.0	1425	37.7	16.00	M_0			-	120.0	120.0	120.0	120.0	120.0	
					M_N				-	107.2	107.2	107.2	107.2	107.2
					$M_{0,max}$				186.5	232.5	268.8	345.7	422.7	458.8
					M_{max}				186.7	232.7	269.0	346.3	423.7	460.9
					η_{eto}				-	-	-	-	-	-
22P17- ...5F□□	105.0	1670	42.7	18.50	M_0				-	120.0	120.0	120.0	120.0	
					M_N				-	-	105.8	105.8	105.8	105.8
					$M_{0,max}$				162.7	204.2	236.9	307.8	374.9	461.2
					M_{max}				162.7	204.2	237.1	308.3	377.0	462.4
					η_{eto}				-	-	-	-	-	-
22P29- ...5F□□	100.0	2935	72.1	30.70	M_0						-	120.0	120.0	
					M_N							-	99.9	99.9
					$M_{0,max}$							180.5	224.5	270.5
					M_{max}							180.8	226.0	271.4
					η_{eto}							-	-	-

- $I...$ [A], $M...$ [Nm], $n...$ [r/min], $P...$ [kW]
- If the motors are operated at a lower switching frequency, please contact your Lenze sales office!

MCA asynchronous servo motors

Technical data



Selection tables, Inverter Drives 8400 TopLine

Forced ventilated IP23s motors

- The data applies to a mains connection voltage of 3 x 400 V and an inverter switching frequency of 8 kHz.

					E84AVTC	□7524	□1134	□1534	□1834	□2234	□3034	□3734	□4534
					I_N	16.5	23.5	32.0	39.0	47.0	61.0	76.0	89.0
					$I_{0,max}$	26.4	32.9	43.2	60.0	70.5	91.5	114.0	133.5
MCA	M_N	n_N	I_N	P_N	I_{max}	33.0	47.0	64.0	78.0	94.0	122.0	152.0	178.0
20X14-...2F□□	61.0	1420	23.0	9.10	M_0	-	67.0	68.0	68.0	68.0			
					M_N	-	61.2	61.2	61.2	61.2			
					$M_{0,max}$	94.8	139.9	192.6	235.5	250.0			
					M_{max}	94.9	139.9	192.8	235.7	250.0			
					η_{eto}	-	-	-	-	-			
20X29-...2F□□	53.5	2930	42.4	16.40	M_0			-	-	57.0	68.0	68.0	68.0
					M_N			-	-	53.4	53.4	53.4	53.4
					$M_{0,max}$			96.8	121.2	140.3	182.5	222.1	250.0
					M_{max}			96.8	121.2	140.4	182.6	223.0	250.0
					η_{eto}			-	-	-	-	-	-
22P08-...2F□□	120.0	760	23.5	9.60	M_0	-	135.0	135.0	135.0	135.0			
					M_N	-	120.6	120.6	120.6	120.6			
					$M_{0,max}$	157.8	234.2	325.4	401.4	400.9			
					M_{max}	157.8	234.8	325.8	401.4	400.9			
					η_{eto}	-	-	-	-	-			
22P14-...2F□□	115.0	1425	40.0	17.20	M_0			-	-	135.0	135.0	135.0	135.0
					M_N			-	-	115.3	115.3	115.3	115.3
					$M_{0,max}$			188.4	235.1	270.8	350.2	425.8	493.6
					M_{max}			188.7	235.1	271.0	350.3	428.1	496.1
					η_{eto}			-	-	-	-	-	-
22P17-...2F□□	112.0	1670	44.5	19.60	M_0			-	-	135.0	135.0	135.0	135.0
					M_N			-	-	112.1	112.1	112.1	112.1
					$M_{0,max}$			163.1	204.6	237.9	309.7	376.9	463.1
					M_{max}			163.1	204.6	238.2	310.6	379.0	465.2
					η_{eto}			-	-	-	-	-	-
22P29-...2F□□	110.0	2935	77.8	33.80	M_0					-	-	-	135.0
					M_N					-	-	-	110.0
					$M_{0,max}$					180.0	224.4	268.2	
					M_{max}					180.7	225.0	269.4	
					η_{eto}					-	-	-	

- $I...$ [A], $M...$ [Nm], $n...$ [r/min], $P...$ [kW]
- If the motors are operated at a lower switching frequency, please contact your Lenze sales office!

MCA asynchronous servo motors

Technical data



Selection tables, Servo Drives ECS

Non-ventilated motors

- The data applies to a mains connection voltage of 3 x 400 V and an inverter switching frequency of 4 kHz.

					ECS□□	008C□B	016C□B	032C□B	048C□B	064C□B
					I_N	4.0	8.0	12.7	17.0	20.0
					$I_{0,max}$	4.6	9.1	18.1	27.2	36.3
MCA	M_N	n_N	I_N	P_N	I_{max}	8.0	16.0	32.0	48.0	64.0
10I40	2.0	3950	2.4	0.80	M_0	2.3				
					M_N	2.0				
					$M_{0,max}$	5.6				
					M_{max}	8.1				
					η_{eto}	-				
13I41	4.0	4050	4.4	1.70	M_0	3.0	4.6			
					M_N	3.0	4.0			
					$M_{0,max}$	4.3	11.0			
					M_{max}	9.4	18.2			
					η_{eto}	-	-			
14L20	6.7	2000	3.3	1.40	M_0	8.0	8.0			
					M_N	6.7	6.7			
					$M_{0,max}$	10.7	25.3			
					M_{max}	21.6	42.8			
					η_{eto}	-	-			
14L41	5.4	4100	5.8	2.30	M_0		8.0	8.0		
					M_N		5.4	5.4		
					$M_{0,max}$		11.0	24.0		
					M_{max}		20.7	29.1		
					η_{eto}		-	-		
17N23	10.8	2300	5.5	2.60	M_0		12.8	12.8		
					M_N		10.8	10.8		
					$M_{0,max}$		20.5	43.5		
					M_{max}		40.2	63.7		
					η_{eto}		-	-		
17N41	9.5	4110	10.2	4.10	M_0		6.1	12.8	12.8	
					M_N		6.1	9.5	9.5	
					$M_{0,max}$		7.8	21.5	33.5	
					M_{max}		17.4	29.6	57.7	
					η_{eto}		-	-	-	
19S23	16.3	2340	8.2	4.00	M_0		15.1	22.5		
					M_N		15.1	16.3		
					$M_{0,max}$		18.7	43.5		
					M_{max}		38.5	67.9		
					η_{eto}		-	-		
19S42	12.0	4150	14.0	5.20	M_0			9.8	16.7	
					M_N			9.8	12.0	
					$M_{0,max}$			18.4	31.9	
					M_{max}			29.9	58.2	
					η_{eto}			-	-	
21X25	24.6	2490	13.5	6.40	M_0			21.0	39.0	
					M_N			21.0	24.6	
					$M_{0,max}$			41.0	64.5	
					M_{max}			64.4	120.5	
					η_{eto}			-	-	

- $I...$ [A], $M...$ [Nm], $n...$ [r/min], $P...$ [kW]

6.11

MCA asynchronous servo motors

Technical data



Selection tables, Servo Drives ECS

Non-ventilated motors

- The data applies to a mains connection voltage of 3 x 400 V and an inverter switching frequency of 4 kHz.

					ECS□□	008C□B	016C□B	032C□B	048C□B	064C□B
					I_N	4.0	8.0	12.7	17.0	20.0
					$I_{0,max}$	4.6	9.1	18.1	27.2	36.3
MCA	M_N	n_N	I_N	P_N	I_{max}	8.0	16.0	32.0	48.0	64.0
21X42	17.0	4160	19.8	7.40	M_0				13.0	17.0
					M_N				13.0	17.0
					$M_{0,max}$				30.0	45.0
					M_{max}				59.4	83.0
					η_{eto}				-	-

- $I...$ [A], $M...$ [Nm], $n...$ [r/min], $P...$ [kW]

MCA asynchronous servo motors

Technical data



Selection tables, Servo Drives ECS

Forced ventilated IP54 motors

- The data applies to a mains connection voltage of 3 x 400 V and an inverter switching frequency of 4 kHz.

					ECS□□	008C□B	016C□B	032C□B	048C□B	064C□B
					I_N	4.0	8.0	12.7	17.0	20.0
					$I_{0,max}$	4.6	9.1	18.1	27.2	36.3
MCA	M_N	n_N	I_N	P_N	I_{max}	8.0	16.0	32.0	48.0	64.0
13I34	6.3	3410	6.0	2.20	M_0		7.0			
					M_N		6.3			
					$M_{0,max}$		10.7			
					M_{max}		20.8			
					η_{eto}		-			
14L16	12.0	1635	4.8	2.10	M_0	8.9	13.5			
					M_N	8.9	12.0			
					$M_{0,max}$	11.5	25.4			
					M_{max}	21.6	46.7			
					η_{eto}	-	-			
14L35	10.8	3455	9.1	3.90	M_0		8.3	13.5	13.5	
					M_N		8.3	10.8	10.8	
					$M_{0,max}$		11.0	27.0	41.0	
					M_{max}		22.2	42.0	60.0	
					η_{eto}		-	-	-	
17N17	21.5	1680	8.5	3.80	M_0		19.5	23.9		
					M_N		19.5	21.5		
					$M_{0,max}$		23.0	53.0		
					M_{max}		44.8	80.0		
					η_{eto}		-	-		
17N35	19.0	3480	15.8	6.90	M_0			12.7	23.0	
					M_N			12.7	19.0	
					$M_{0,max}$			23.0	37.5	
					M_{max}			37.7	64.4	
					η_{eto}			-	-	
19S17	36.3	1700	13.9	6.40	M_0			28.3	40.0	40.0
					M_N			28.3	36.3	36.3
					$M_{0,max}$			46.5	72.0	98.0
					M_{max}			75.4	130.8	158.9
					η_{eto}			-	-	-
21X17	61.4	1710	22.5	11.00	M_0					52.5
					M_N					52.5
					$M_{0,max}$					107.0
					M_{max}					190.0
					η_{eto}					-

- I... [A], M... [Nm], n... [r/min], P... [kW]

MCA asynchronous servo motors

Technical data



Selection tables, Servo Inverter 9300

Non-ventilated motors

- The data applies to a mains connection voltage of 3 x 400 V and an inverter switching frequency of 8 kHz.

					EVS	9322-E□	9323-E□	9324-E□	9325-E□	9326-E□	9327-E□	9328-E□	9329-E□
					I_N	2.5	3.9	7.0	13.0	23.5	32.0	47.0	59.0
					$I_{0,max}$	3.8	5.9	10.5	19.5	23.5	32.0	47.0	52.0
MCA	M_N	n_N	I_N	P_N	I_{max}	3.8	5.9	10.5	19.5	35.3	48.0	70.5	88.5
10I40	2.0	3950	2.4	0.80	M_0	2.2	2.3						
					M_N	2.0	2.0						
					$M_{0,max}$	4.4	7.3						
					M_{max}	4.4	7.3						
					η_{eto}	-	-						
13I41	4.0	4050	4.4	1.70	M_0			4.6	4.6				
					M_N			4.0	4.0				
					$M_{0,max}$			12.6	19.5				
					M_{max}			12.6	19.5				
					η_{eto}			-	-				
14L20	6.7	2000	3.3	1.40	M_0		8.0	8.0					
					M_N		6.7	6.7					
					$M_{0,max}$		15.1	29.3					
					M_{max}		15.1	29.3					
					η_{eto}		-	-					
14L41	5.4	4100	5.8	2.30	M_0			7.0	8.0				
					M_N			5.4	5.4				
					$M_{0,max}$			13.2	26.0				
					M_{max}			13.2	26.0				
					η_{eto}			-	-				
17N23	10.8	2300	5.5	2.60	M_0			12.8	12.8				
					M_N			10.8	10.8				
					$M_{0,max}$			24.4	46.2				
					M_{max}			24.4	46.2				
					η_{eto}			-	-				
17N41	9.5	4110	10.2	4.10	M_0			12.8	12.8	12.8			
					M_N			9.5	9.5	9.5			
					$M_{0,max}$			23.4	37.0	54.0			
					M_{max}			23.4	43.7	59.4			
					η_{eto}			-	-	-			
19S23	16.3	2340	8.2	4.00	M_0			22.5	22.5				
					M_N			16.3	16.3				
					$M_{0,max}$			47.2	78.0				
					M_{max}			47.2	88.2				
					η_{eto}			-	-				
19S42	12.0	4150	14.0	5.20	M_0			10.0	22.5	22.5			
					M_N			10.0	12.0	12.0			
					$M_{0,max}$			20.7	33.5	51.0			
					M_{max}			20.7	43.3	60.7			
					η_{eto}			-	-	-			
21X25	24.6	2490	13.5	6.40	M_0			23.7	39.0	39.0			
					M_N			23.7	24.6	24.6			
					$M_{0,max}$			46.2	66.0	84.0			
					M_{max}			46.2	78.0	92.4			
					η_{eto}			-	-	-			

- $I...$ [A], $M...$ [Nm], $n...$ [r/min], $P...$ [kW]

MCA asynchronous servo motors

Technical data



Selection tables, Servo Inverter 9300

Non-ventilated motors

- The data applies to a mains connection voltage of 3 x 400 V and an inverter switching frequency of 8 kHz.

					EVS	9322-E□	9323-E□	9324-E□	9325-E□	9326-E□	9327-E□	9328-E□	9329-E□
					I_N	2.5	3.9	7.0	13.0	23.5	32.0	47.0	59.0
					$I_{0,max}$	3.8	5.9	10.5	19.5	23.5	32.0	47.0	52.0
MCA	M_N	n_N	I_N	P_N	I_{max}	3.8	5.9	10.5	19.5	35.3	48.0	70.5	88.5
21X42	17.0	4160	19.8	7.40	M_0					24.0	39.0	39.0	39.0
					M_N					17.0	17.0	17.0	17.0
					$M_{0,max}$					24.0	47.0	84.0	94.0
					M_{max}					43.9	63.3	96.8	123.0
					n_{eto}					-	-	-	-

- $I...$ [A], $M...$ [Nm], $n...$ [r/min], $P...$ [kW]

MCA asynchronous servo motors

Technical data



Selection tables, Servo Inverter 9300

Forced ventilated IP54 motors

- The data applies to a mains connection voltage of 3 x 400 V and an inverter switching frequency of 8 kHz.

					EVS	9324-E□	9325-E□	9326-E□	9327-E□	9328-E□	9329-E□	9330-E□	9331-E□
					I_N	7.0	13.0	23.5	32.0	47.0	59.0	89.0	110.0
					$I_{0,max}$	10.5	19.5	23.5	32.0	47.0	52.0	80.0	110.0
MCA	M_N	n_N	I_N	P_N	I_{max}	10.5	19.5	35.3	48.0	70.5	88.5	133.5	165.0
13I34	6.3	3410	6.0	2.20	M_0	7.0	7.0						
					M_N	6.3	6.3						
					$M_{0,max}$	13.0	25.0						
					M_{max}	13.0	25.0						
					η_{eto}	-	-						
14L16	12.0	1635	4.8	2.10	M_0	13.5							
					M_N	12.0							
					$M_{0,max}$	29.6							
					M_{max}	29.6							
					η_{eto}	-							
14L35	10.8	3455	9.1	3.90	M_0		13.5	13.5					
					M_N		10.8	10.8					
					$M_{0,max}$		29.3	47.0					
					M_{max}		29.3	53.8					
					η_{eto}		-	-					
17N17	21.5	1680	8.5	3.80	M_0		23.9						
					M_N		21.5						
					$M_{0,max}$		57.2						
					M_{max}		57.2						
					η_{eto}		-						
17N35	19.0	3480	15.8	6.90	M_0			23.9	23.9	23.9			
					M_N			19.0	19.0	19.0			
					$M_{0,max}$			27.5	57.0	89.0			
					M_{max}			50.7	69.2	100.2			
					η_{eto}			-	-	-			
19S17	36.3	1700	13.9	6.40	M_0		34.0	40.0	40.0				
					M_N		34.0	36.3	36.3				
					$M_{0,max}$		50.1	76.0	112.0				
					M_{max}		50.1	95.9	130.8				
					η_{eto}		-	-	-				
19S35	36.0	3510	28.7	13.20	M_0			21.0	39.0	40.0	40.0	40.0	
					M_N			21.0	36.0	36.0	36.0	36.0	
					$M_{0,max}$			21.0	39.0	73.0	80.0	161.5	
					M_{max}			45.7	67.6	104.3	132.9	180.0	
					η_{eto}			-	-	-	-	-	
21X17	61.4	1710	22.5	11.00	M_0			65.5	75.0	75.0	75.0		
					M_N			61.4	61.4	61.4	61.4		
					$M_{0,max}$			65.5	102.0	178.0	200.0		
					M_{max}			104.1	143.3	210.7	257.3		
					η_{eto}			-	-	-	-		
21X35	55.0	3520	42.5	20.30	M_0					68.0	75.0	75.0	75.0
					M_N					55.0	55.0	55.0	55.0
					$M_{0,max}$					68.0	88.0	156.0	219.0
					M_{max}					107.7	135.9	205.0	250.1
					η_{eto}					-	-	-	-

- $I...$ [A], $M...$ [Nm], $n...$ [r/min], $P...$ [kW]

MCA asynchronous servo motors



Technical data

Selection tables, Servo Inverter 9300

Forced ventilated IP54 motors

- The data applies to a mains connection voltage of 3 x 400 V and an inverter switching frequency of 8 kHz.

					EVS	9326-E□	9327-E□	9328-E□	9329-E□	9330-E□	9331-E□	9332-E□
					I_N	23.5	32.0	47.0	59.0	89.0	110.0	145.0
					$I_{0,max}$	23.5	32.0	47.0	52.0	80.0	110.0	126.0
MCA	M_N	n_N	I_N	P_N	I_{max}	35.3	48.0	70.5	88.5	133.5	165.0	217.5
22P08-...5F□□	110.0	760	22.1	8.80	M_0	115.0	120.0	120.0	120.0			
					M_N	108.0	110.0	110.0	110.0			
					$M_{0,max}$	115.0	166.0	242.0	267.0			
					M_{max}	185.0	247.0	338.8	345.8			
					η_{eto}	-	-	-	-			
22P14-...5F□□	107.0	1425	37.7	16.00	M_0			120.0	120.0	120.0		
					M_N			107.0	107.0	107.0		
					$M_{0,max}$			146.0	160.0	264.0		
					M_{max}			230.1	292.9	341.8		
					η_{eto}			-	-	-		
22P17-...5F□□	105.0	1670	42.7	18.50	M_0			120.0	120.0	120.0	120.0	
					M_N			106.0	106.0	106.0	106.0	
					$M_{0,max}$			124.0	140.0	240.0	335.0	
					M_{max}			180.5	227.7	342.1	378.3	
					η_{eto}			-	-	-	-	
22P29-...5F□□	100.0	2935	72.1	30.70	M_0					118.0	120.0	120.0
					M_N					100.0	100.0	100.0
					$M_{0,max}$					122.0	171.0	200.0
					M_{max}					215.6	273.1	355.1
					η_{eto}					-	-	-
26T05-...5F□□	216.0	550	34.9	12.40	M_0		191.0	220.0	220.0	220.0		
					M_N		191.0	216.0	216.0	216.0		
					$M_{0,max}$		191.0	303.0	333.0	615.0		
					M_{max}		313.0	482.0	612.0	751.0		
					η_{eto}		-	-	-	-		
26T10-...5F□□	210.0	1030	61.5	22.70	M_0				159.0	220.0	220.0	
					M_N				197.0	210.0	210.0	
					$M_{0,max}$				159.0	300.0	440.0	
					M_{max}				343.0	552.0	671.0	
					η_{eto}				-	-	-	
26T12-...5F□□	207.0	1200	75.1	26.00	M_0					207.0	220.0	220.0
					M_N					255.0	207.0	207.0
					$M_{0,max}$					258.0	327.0	397.0
					M_{max}					424.0	512.0	663.0
					η_{eto}					-	-	-
26T22-...5F□□	195.0	2235	112.9	45.60	M_0						177.0	220.0
					M_N						177.0	195.0
					$M_{0,max}$						203.0	220.0
					M_{max}						315.0	432.0
					η_{eto}						-	-

- $I...$ [A], $M...$ [Nm], $n...$ [r/min], $P...$ [kW]
- If the motors are operated at a lower switching frequency, please contact your Lenze sales office!

MCA asynchronous servo motors

Technical data



Selection tables, Servo Inverter 9300

Forced ventilated IP23s motors

- The data applies to a mains connection voltage of 3 x 400 V and an inverter switching frequency of 8 kHz.

					EVS	9326-E□	9327-E□	9328-E□	9329-E□	9330-E□	9331-E□	9332-E□
					I_N	23.5	32.0	47.0	59.0	89.0	110.0	145.0
					$I_{0,max}$	23.5	32.0	47.0	52.0	80.0	110.0	126.0
MCA	M_N	n_N	I_N	P_N	I_{max}	35.3	48.0	70.5	88.5	133.5	165.0	217.5
20X14-...2F□□	61.0	1420	23.0	9.10	M_0	61.0	68.0	68.0				
					M_N	61.0	61.0	61.0				
					$M_{0,max}$	61.0	93.0	153.0				
					M_{max}	109.3	156.7	232.1				
					η_{eto}	-	-	-				
20X29-...2F□□	53.5	2930	42.4	16.40	M_0		28.0	66.3	68.0	68.0		
					M_N		28.0	53.5	53.5	53.5		
					$M_{0,max}$		28.0	66.3	72.0	129.0		
					M_{max}		68.5	112.5	146.4	226.7		
					η_{eto}		-	-	-	-		
22P08-...2F□□	120.0	760	23.5	9.60	M_0	115.0	135.0	135.0	135.0			
					M_N	115.0	120.0	120.0	120.0			
					$M_{0,max}$	115.0	166.0	242.0	267.0			
					M_{max}	185.0	247.0	338.8	345.8			
					η_{eto}	-	-	-	-			
22P14-...2F□□	115.0	1425	40.0	17.20	M_0			135.0	135.0	135.0		
					M_N			115.0	115.0	115.0		
					$M_{0,max}$			146.0	160.0	264.0		
					M_{max}			230.1	292.9	341.8		
					η_{eto}			-	-	-		
22P17-...2F□□	112.0	1670	44.5	19.60	M_0			124.0	134.0	135.0	135.0	
					M_N			112.0	112.0	112.0	112.0	
					$M_{0,max}$			124.0	140.0	240.0	335.0	
					M_{max}			180.5	227.7	342.1	378.3	
					η_{eto}			-	-	-	-	
22P29-...2F□□	110.0	2935	77.8	33.80	M_0					118.0	135.0	135.0
					M_N					110.0	110.0	110.0
					$M_{0,max}$					122.0	171.0	200.0
					M_{max}					215.6	273.1	355.1
					η_{eto}					-	-	-
26T05-...2F□□	280.0	550	42.4	16.10	M_0		191.0	290.0	290.0	290.0		
					M_N		191.0	280.0	280.0	280.0		
					$M_{0,max}$		191.0	303.0	333.0	615.0		
					M_{max}		313.0	482.0	612.0	751.0		
					η_{eto}		-	-	-	-		
26T10-...2F□□	260.0	1030	69.6	28.00	M_0				159.0	290.0	290.0	
					M_N				197.0	260.0	260.0	
					$M_{0,max}$				159.0	300.0	440.0	
					M_{max}				343.0	552.0	671.0	
					η_{eto}				-	-	-	

- $I...$ [A], $M...$ [Nm], $n...$ [r/min], $P...$ [kW]
- If the motors are operated at a lower switching frequency, please contact your Lenze sales office!

MCA asynchronous servo motors

Technical data



Selection tables, Servo Inverter 9300

Forced ventilated IP23s motors

- The data applies to a mains connection voltage of 3 x 400 V and an inverter switching frequency of 8 kHz.

					EVS	9326-E□	9327-E□	9328-E□	9329-E□	9330-E□	9331-E□	9332-E□
					I_N	23.5	32.0	47.0	59.0	89.0	110.0	145.0
					$I_{0,max}$	23.5	32.0	47.0	52.0	80.0	110.0	126.0
MCA	M_N	n_N	I_N	P_N	I_{max}	35.3	48.0	70.5	88.5	133.5	165.0	217.5
26T12- ...2F□□	255.0	1200	83.3	32.00	M_0					232.0	290.0	290.0
					M_N					255.0	255.0	255.0
					$M_{0,max}$					258.0	327.0	397.0
					M_{max}					424.0	512.0	663.0
					η_{eto}					-	-	-
26T22- ...2F□□	230.0	2235	126.7	53.80	M_0						177.0	222.0
					M_N						177.0	230.0
					$M_{0,max}$						203.0	220.0
					M_{max}						315.0	432.0
					η_{eto}						-	-

- $I...$ [A], $M...$ [Nm], $n...$ [r/min], $P...$ [kW]
- If the motors are operated at a lower switching frequency, please contact your Lenze sales office!

MCA asynchronous servo motors

Technical data



Torque characteristics

- ▶ The data applies to a mains connection voltage of 3 x 400 V.
- ▶ You can find further torque characteristics at www.lenze.de/dsc.

MCA10I40 (non-ventilated)

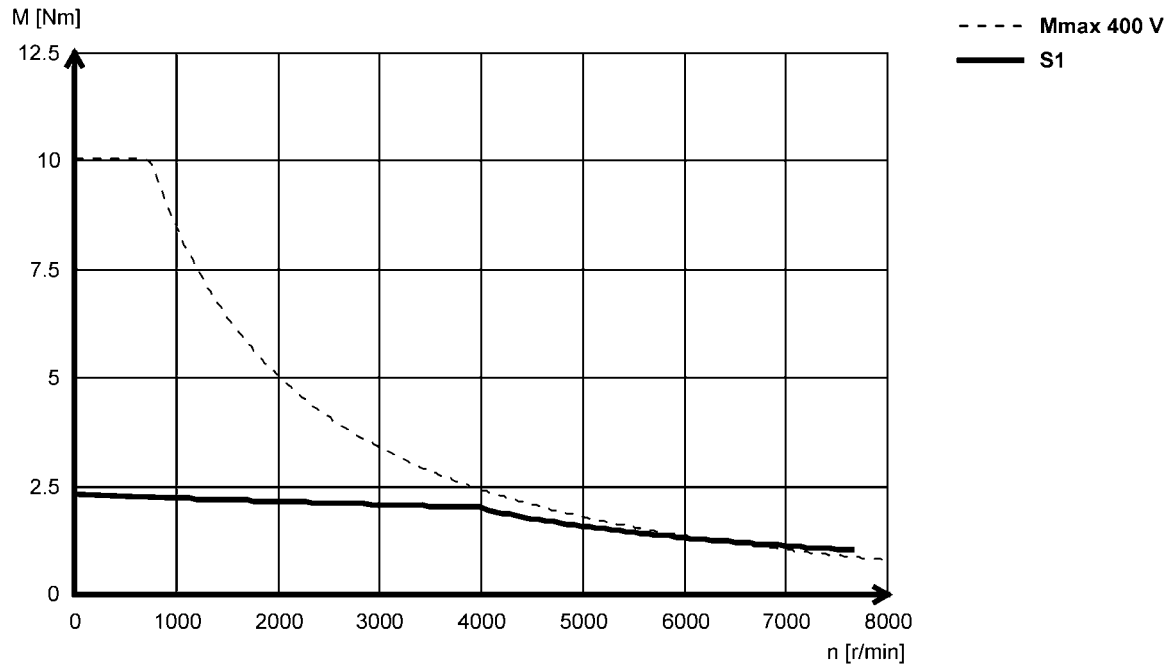

MCA asynchronous servo motors



Technical data

Torque characteristics

- ▶ The data applies to a mains connection voltage of 3 x 400 V.
- ▶ You can find further torque characteristics at www.lenze.de/dsc.

MCA13134 (forced ventilated)

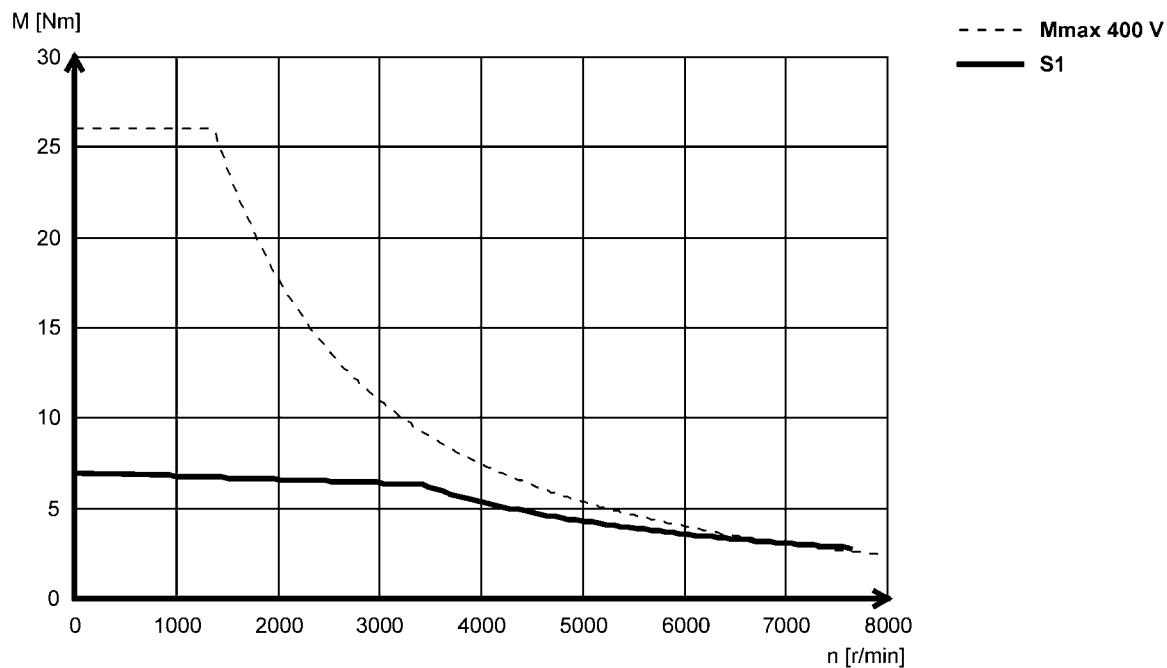

MCA13141 (non-ventilated)

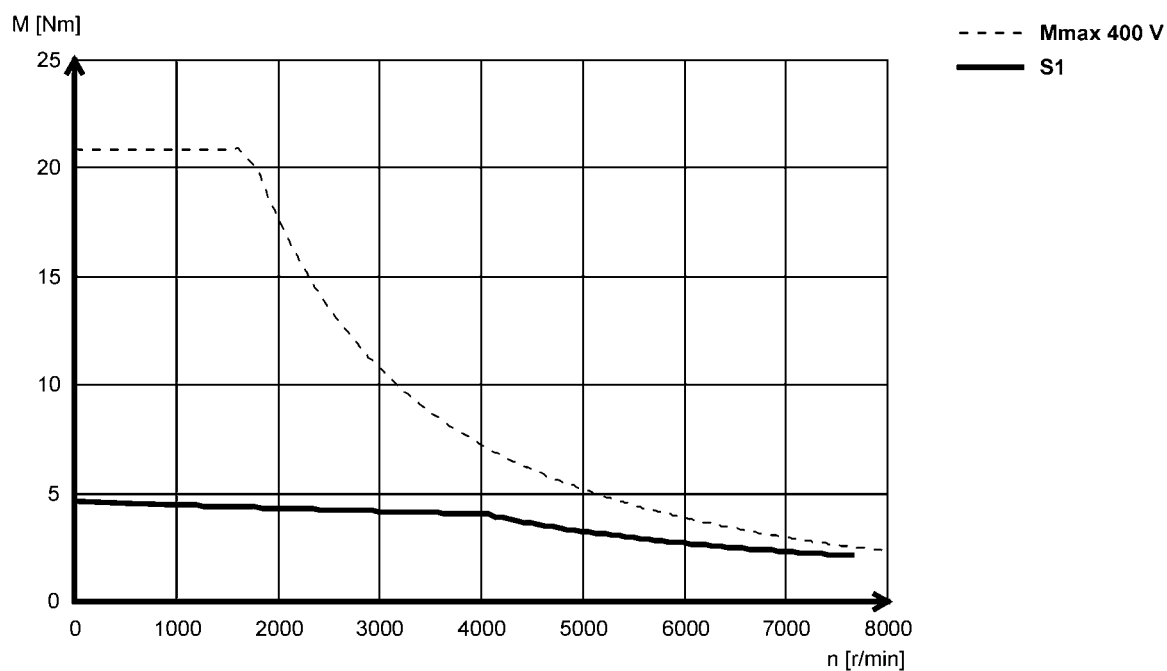

MCA asynchronous servo motors



Technical data

Torque characteristics

- ▶ The data applies to a mains connection voltage of 3 x 400 V.
- ▶ You can find further torque characteristics at www.lenze.de/dsc.

MCA14L16 (forced ventilated)

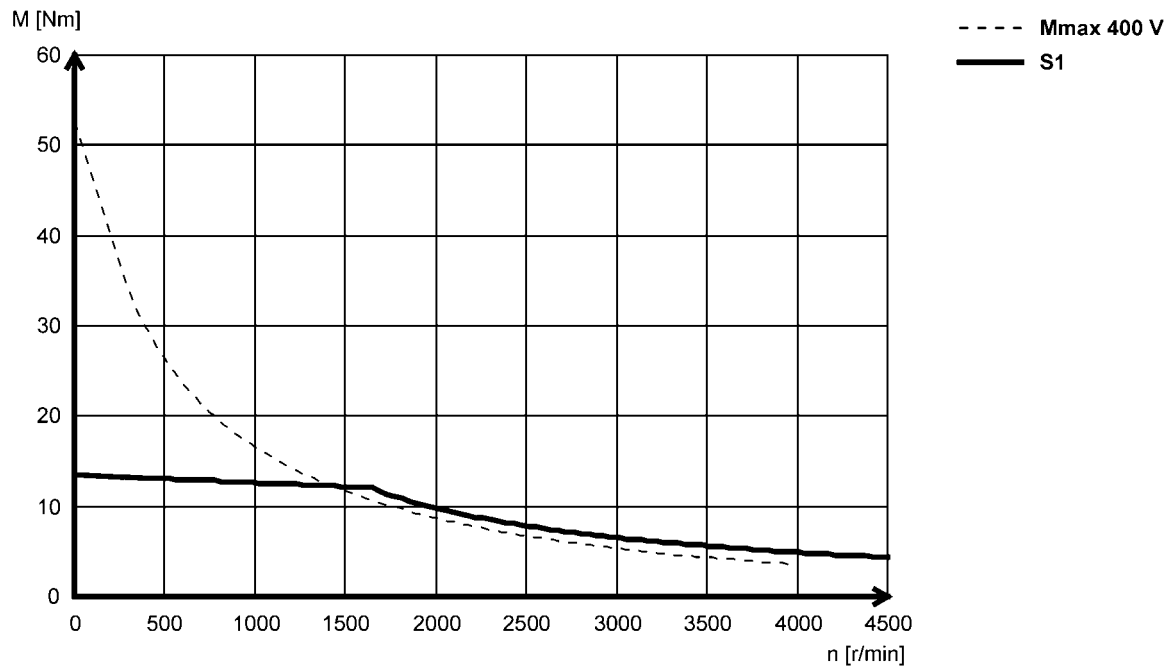

MCA14L20 (non-ventilated)

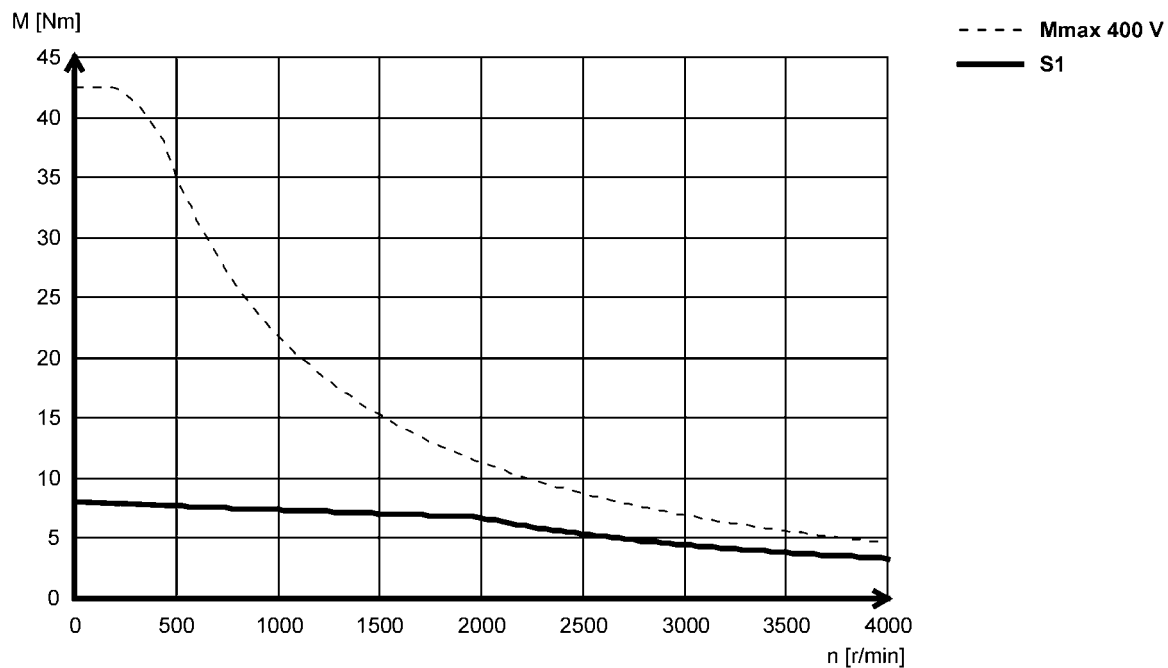

MCA asynchronous servo motors



Technical data

Torque characteristics

- ▶ The data applies to a mains connection voltage of 3 x 400 V.
- ▶ You can find further torque characteristics at www.lenze.de/dsc.

MCA14L35 (forced ventilated)

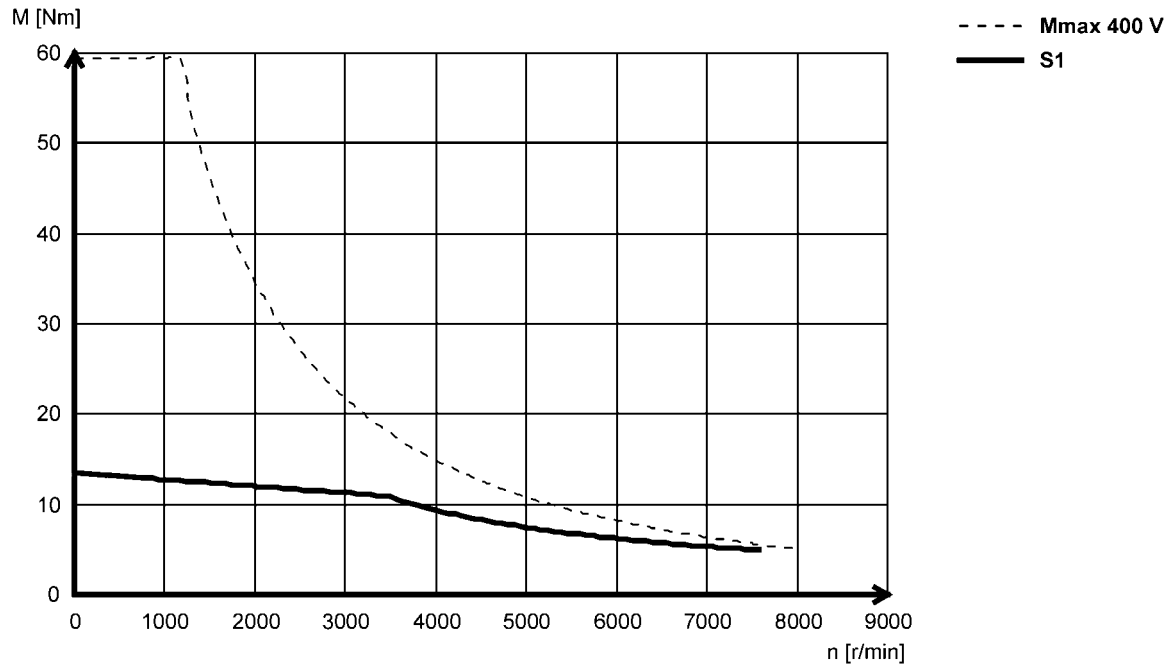

MCA14L41 (non-ventilated)

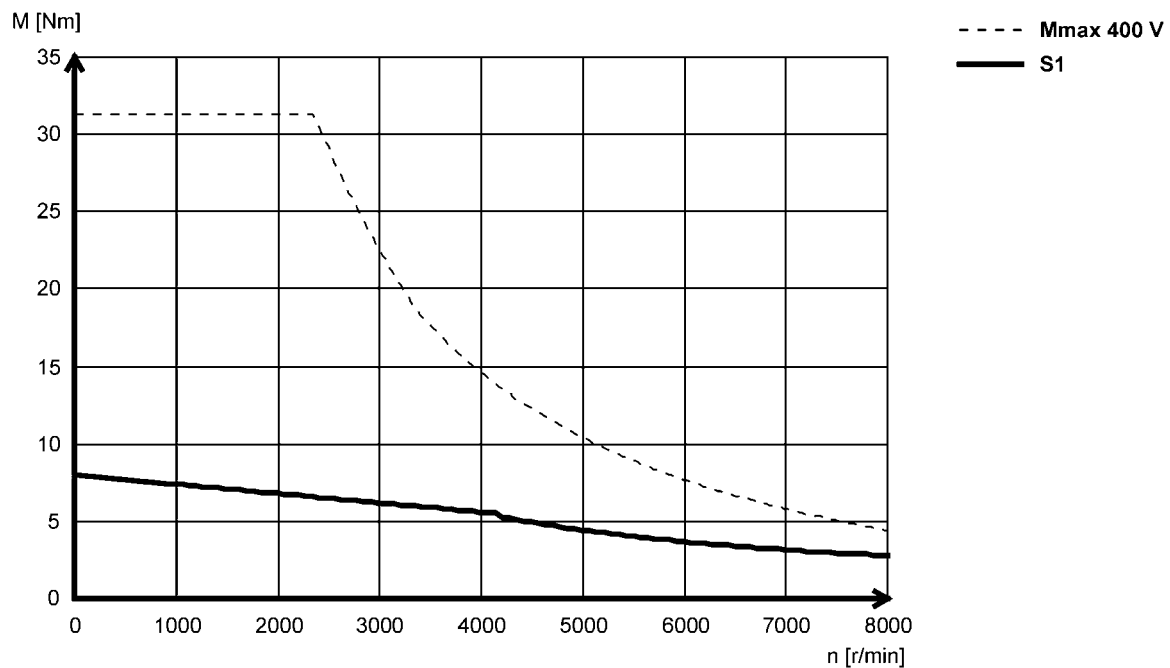

MCA asynchronous servo motors



Technical data

Torque characteristics

- ▶ The data applies to a mains connection voltage of 3 x 400 V.
- ▶ You can find further torque characteristics at www.lenze.de/dsc.

MCA17N17 (forced ventilated)

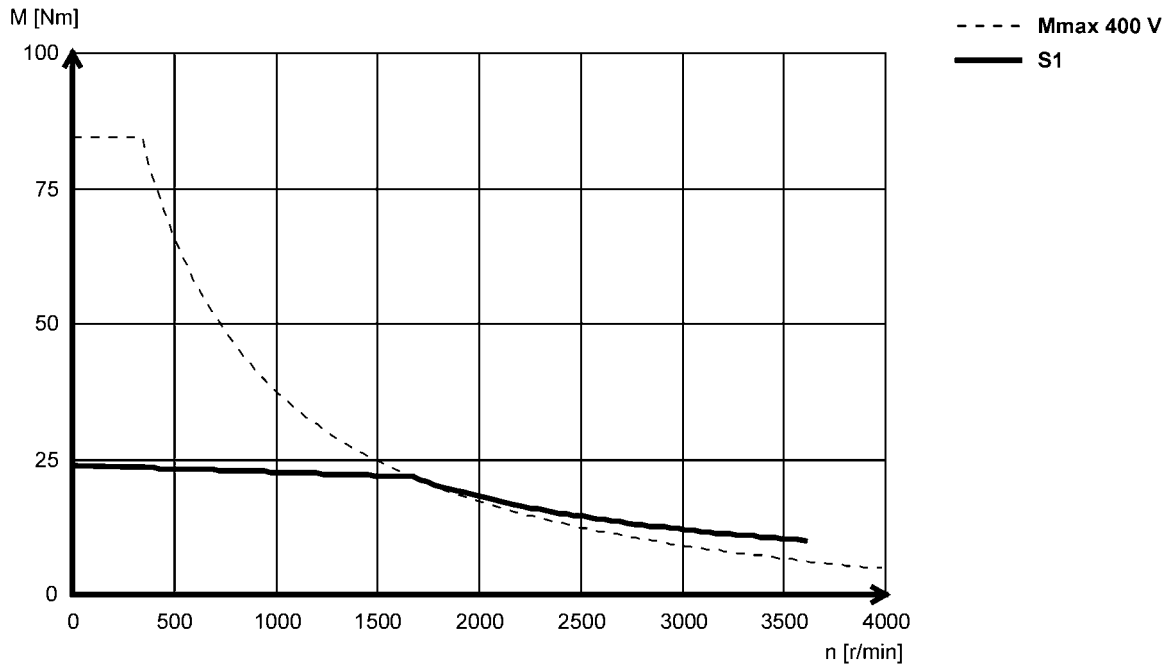

MCA17N23 (non-ventilated)

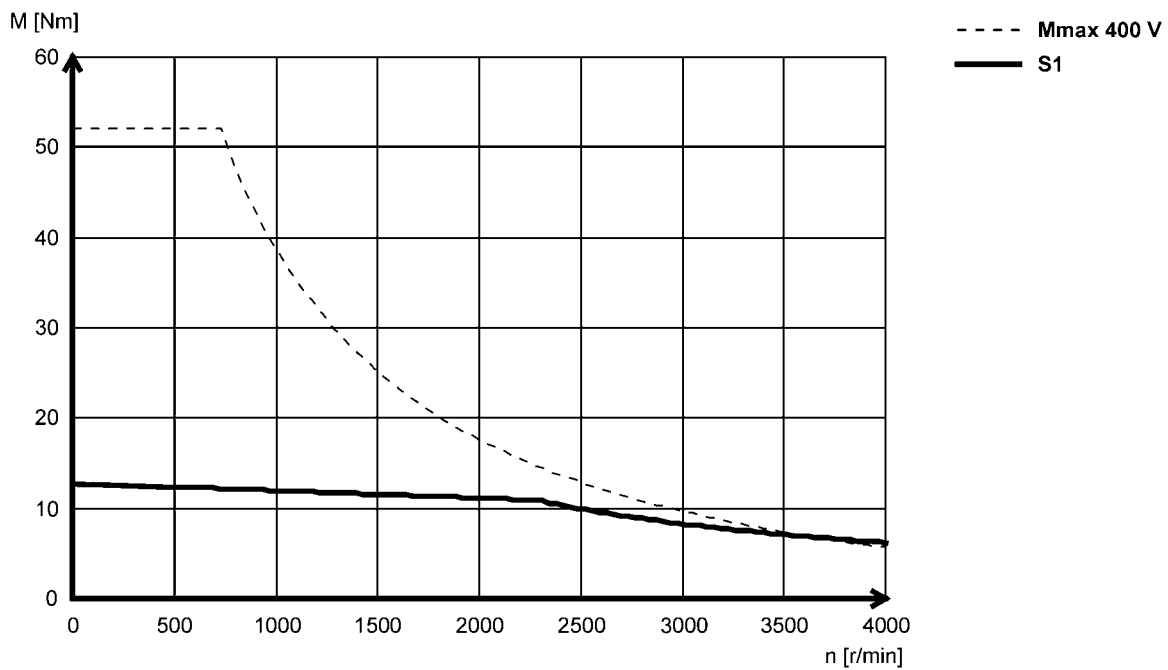

MCA asynchronous servo motors

Technical data



Torque characteristics

- ▶ The data applies to a mains connection voltage of 3 x 400 V.
- ▶ You can find further torque characteristics at www.lenze.de/dsc.

MCA17N35 (forced ventilated)

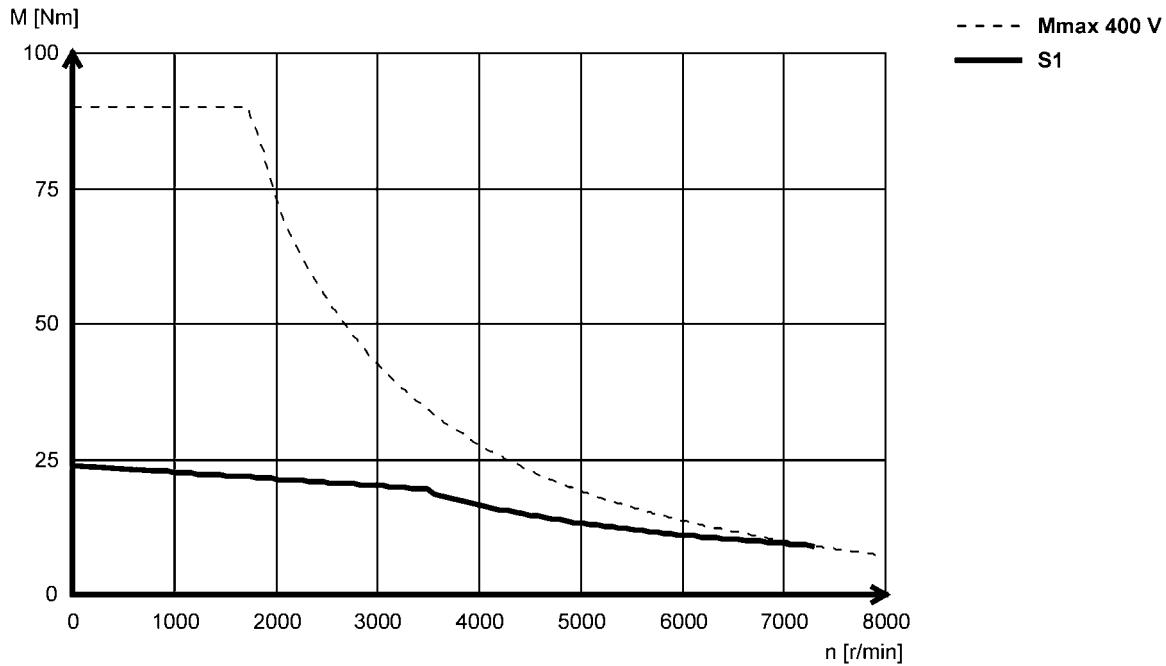

MCA17N41 (non-ventilated)

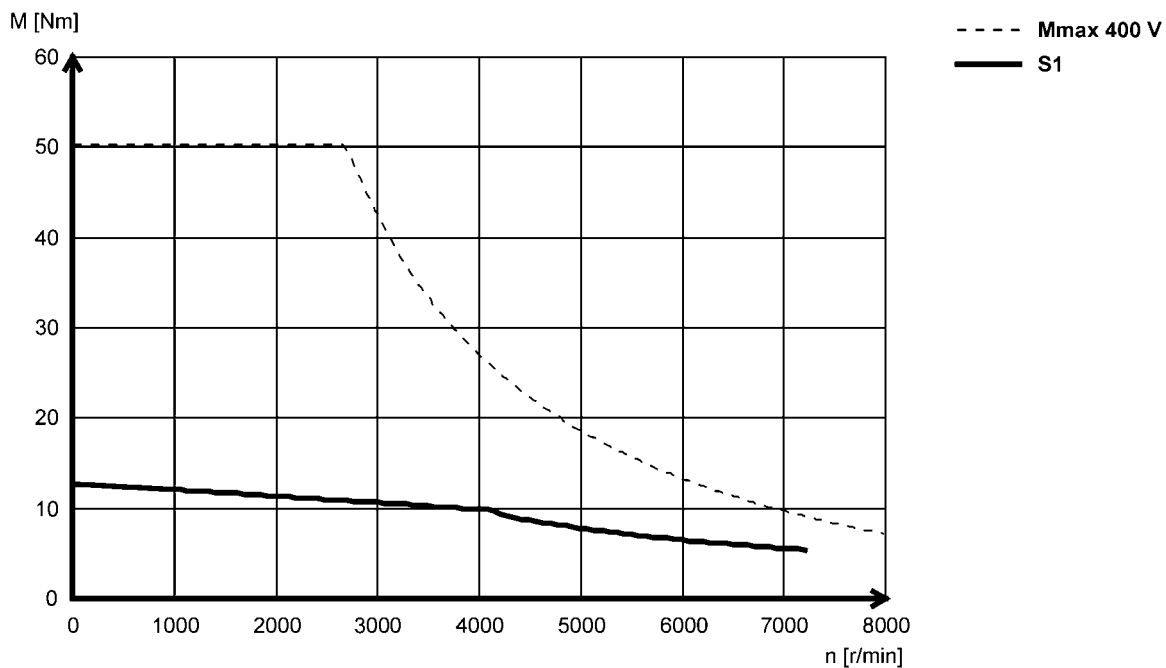

6.11

MCA asynchronous servo motors

Technical data



Torque characteristics

- ▶ The data applies to a mains connection voltage of 3 x 400 V.
- ▶ You can find further torque characteristics at www.lenze.de/dsc.

MCA19S17 (forced ventilated)

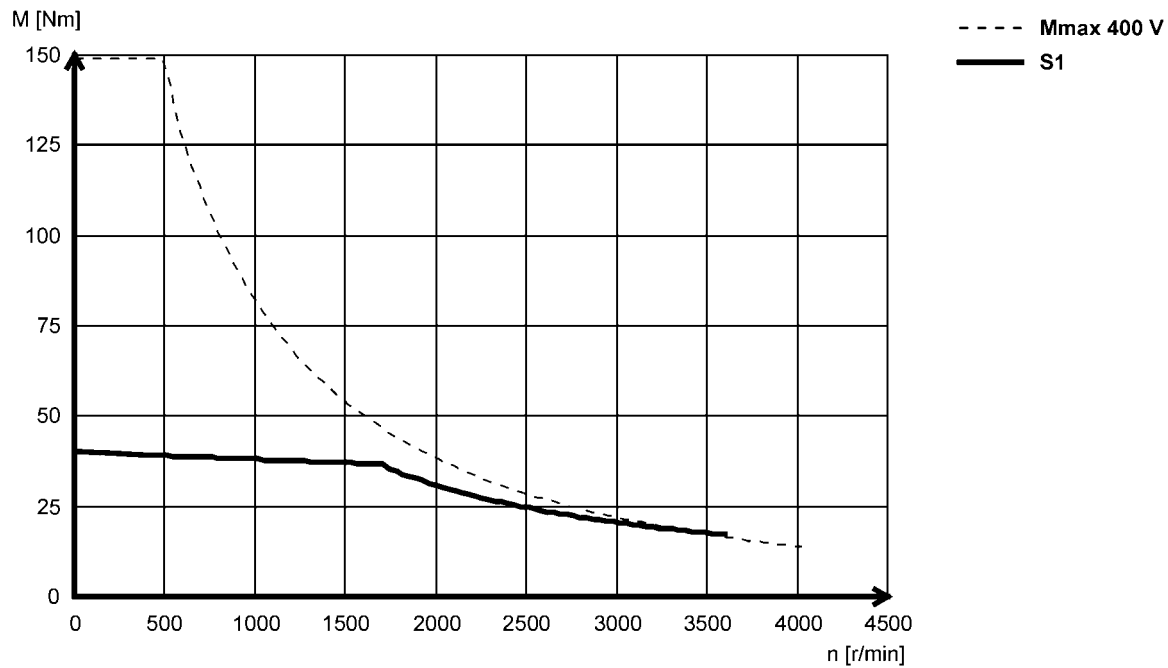

MCA19S23 (non-ventilated)

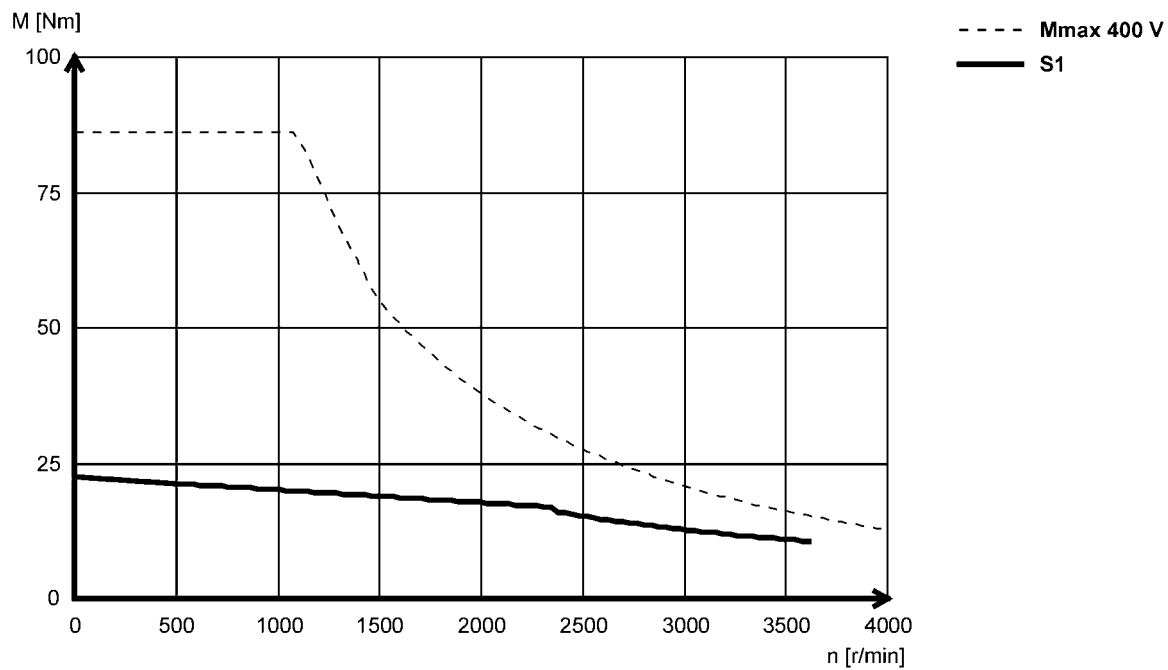

6.11

MCA asynchronous servo motors

Technical data



Torque characteristics

- ▶ The data applies to a mains connection voltage of 3 x 400 V.
- ▶ You can find further torque characteristics at www.lenze.de/dsc.

MCA19S35 (forced ventilated)

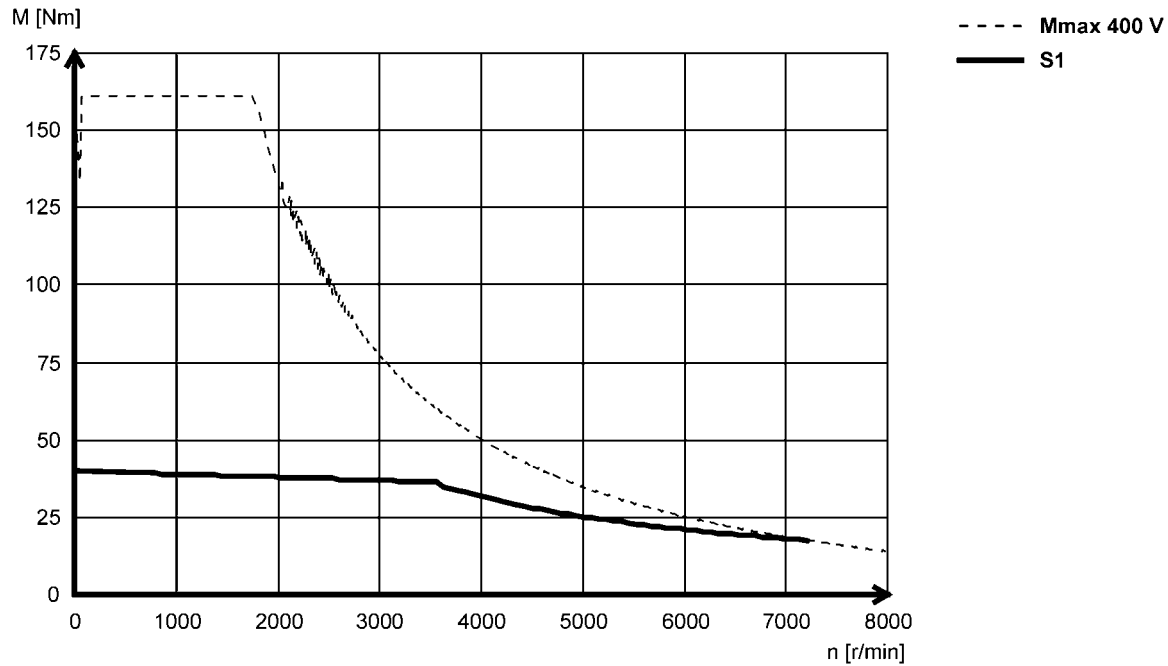

MCA19S42 (non-ventilated)

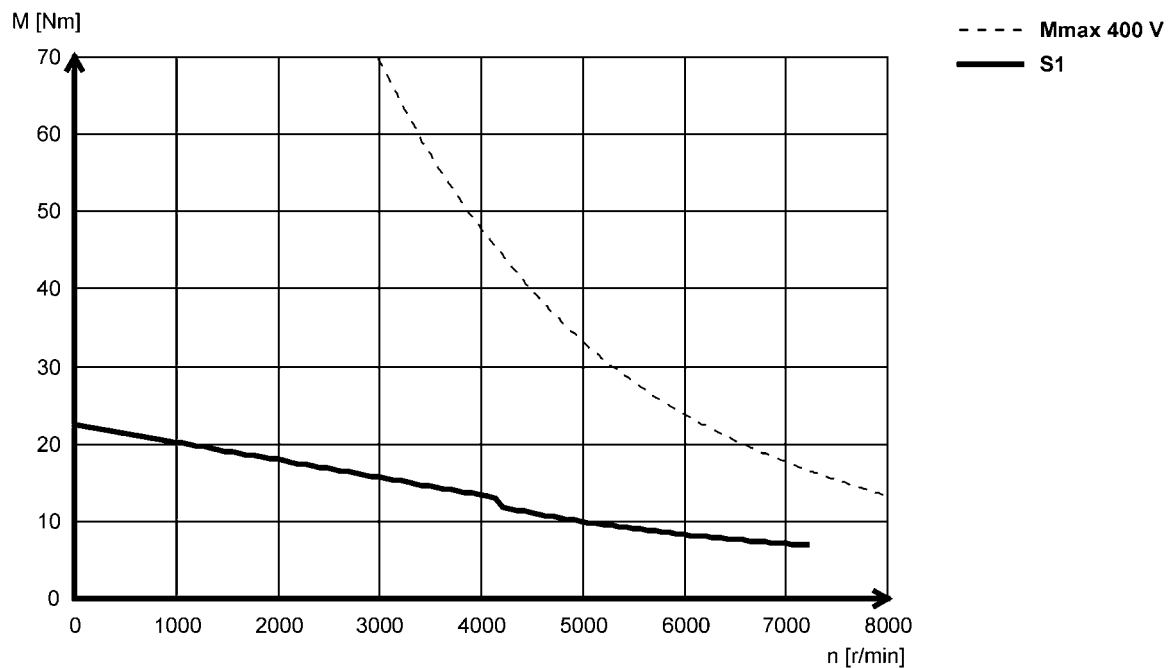

6.11

MCA asynchronous servo motors



Technical data

Torque characteristics

- ▶ The data applies to a mains connection voltage of 3 x 400 V.
- ▶ You can find further torque characteristics at www.lenze.de/dsc.

MCA20X14...2F□□ (forced ventilated)

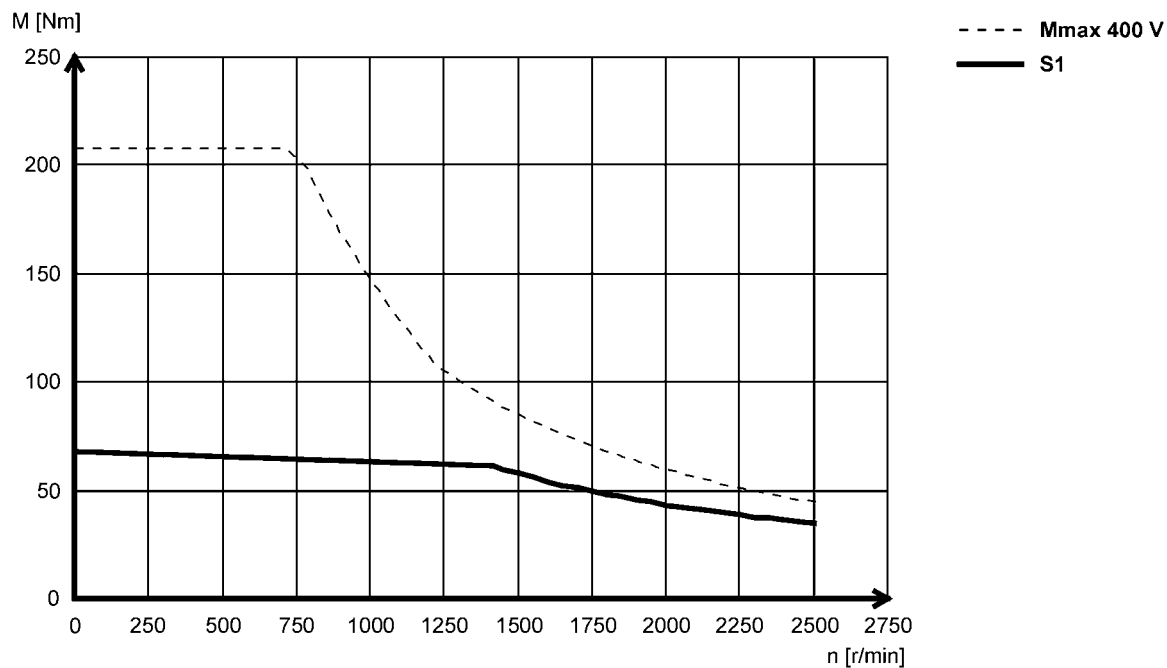

MCA20X29...2F□□ (forced ventilated)

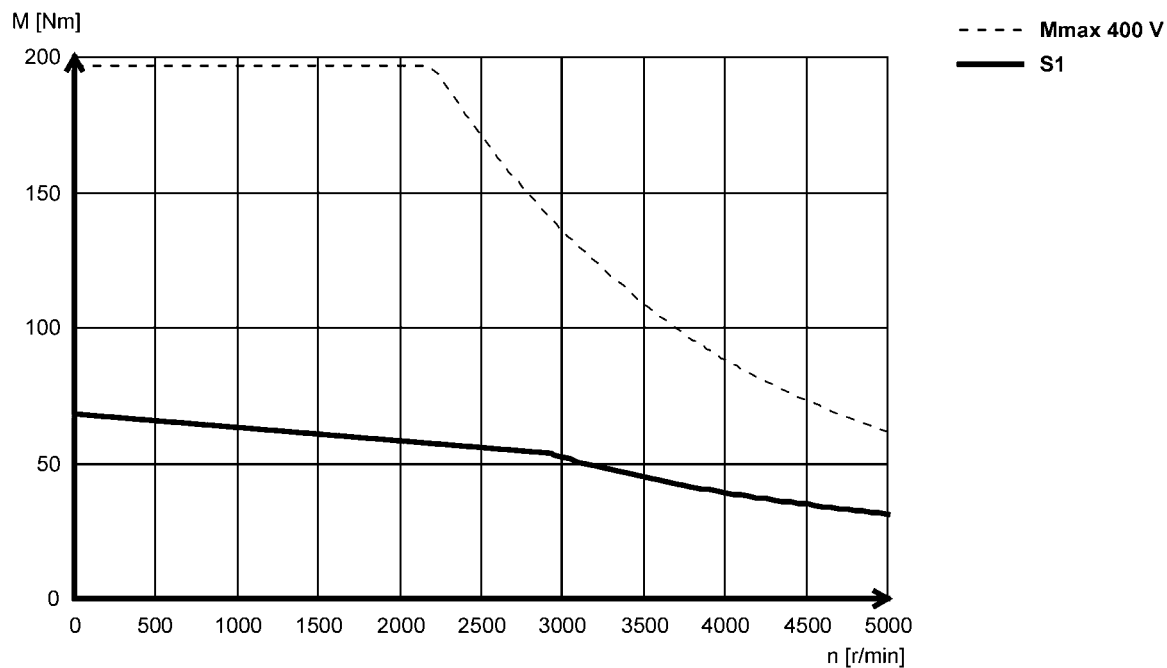

MCA asynchronous servo motors

Technical data



Torque characteristics

- ▶ The data applies to a mains connection voltage of 3 x 400 V.
- ▶ You can find further torque characteristics at www.lenze.de/dsc.

MCA21X17 (forced ventilated)

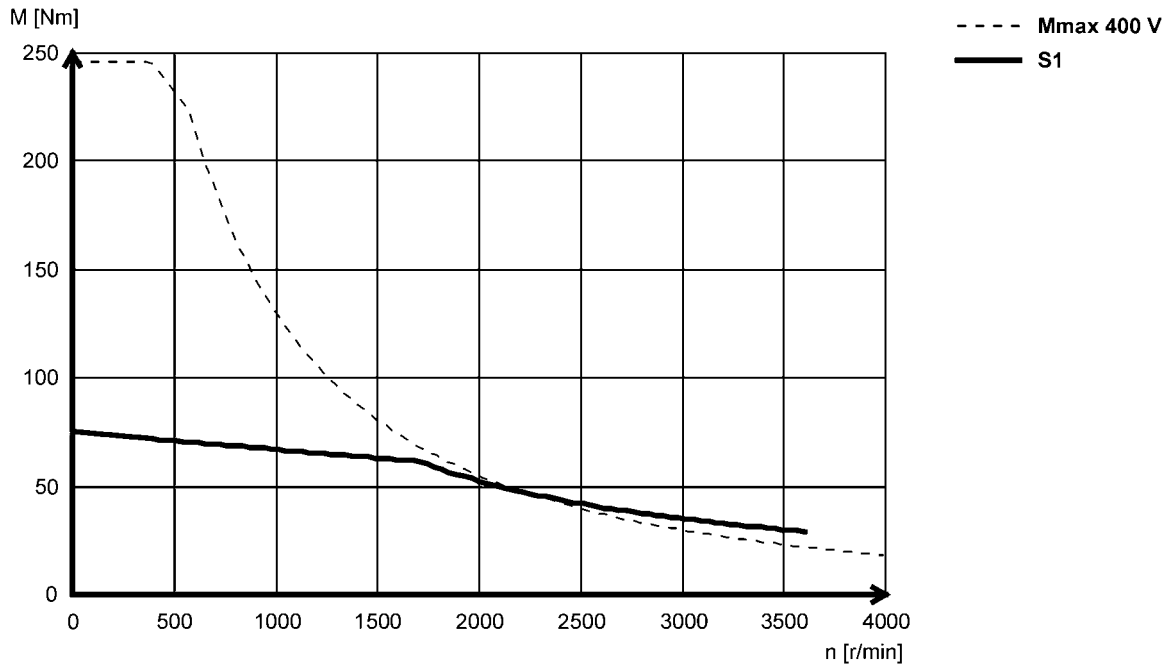

MCA21X25 (non-ventilated)

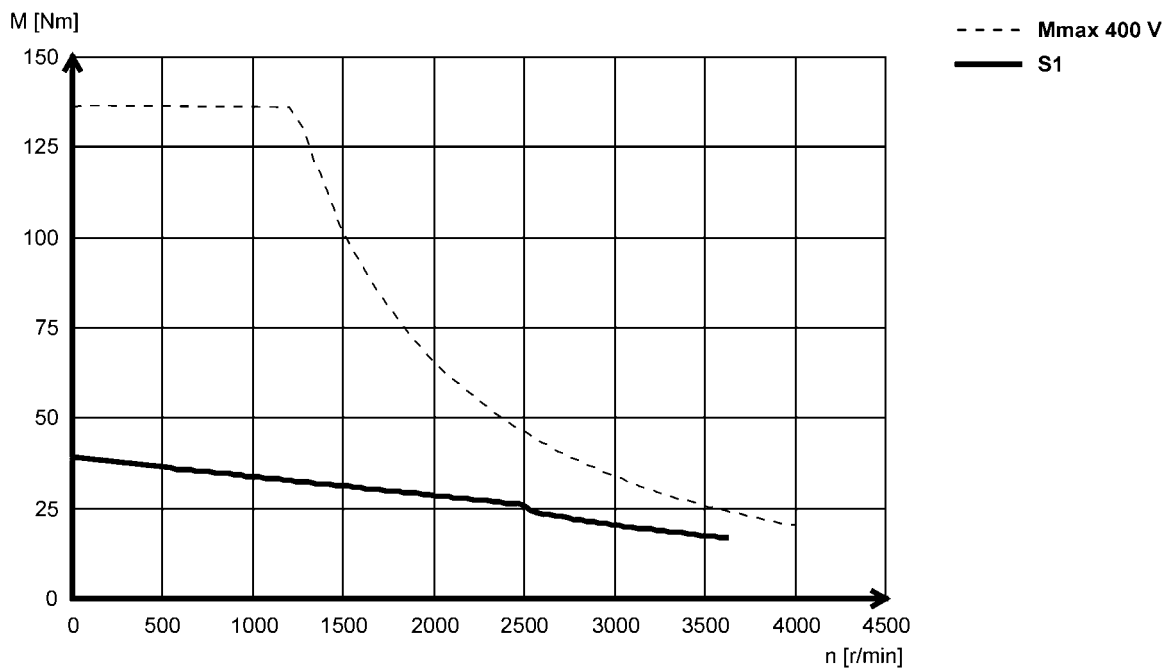

6.11

MCA asynchronous servo motors

Technical data



Torque characteristics

- ▶ The data applies to a mains connection voltage of 3 x 400 V.
- ▶ You can find further torque characteristics at www.lenze.de/dsc.

MCA21X35 (forced ventilated)

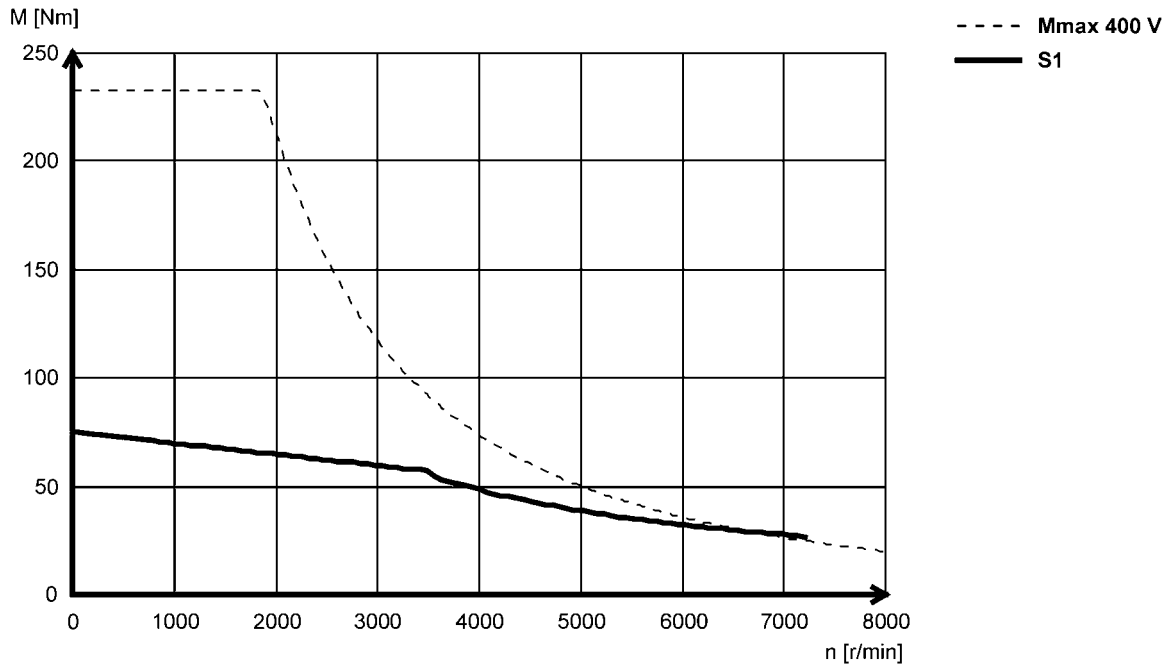

MCA21X42 (non-ventilated)

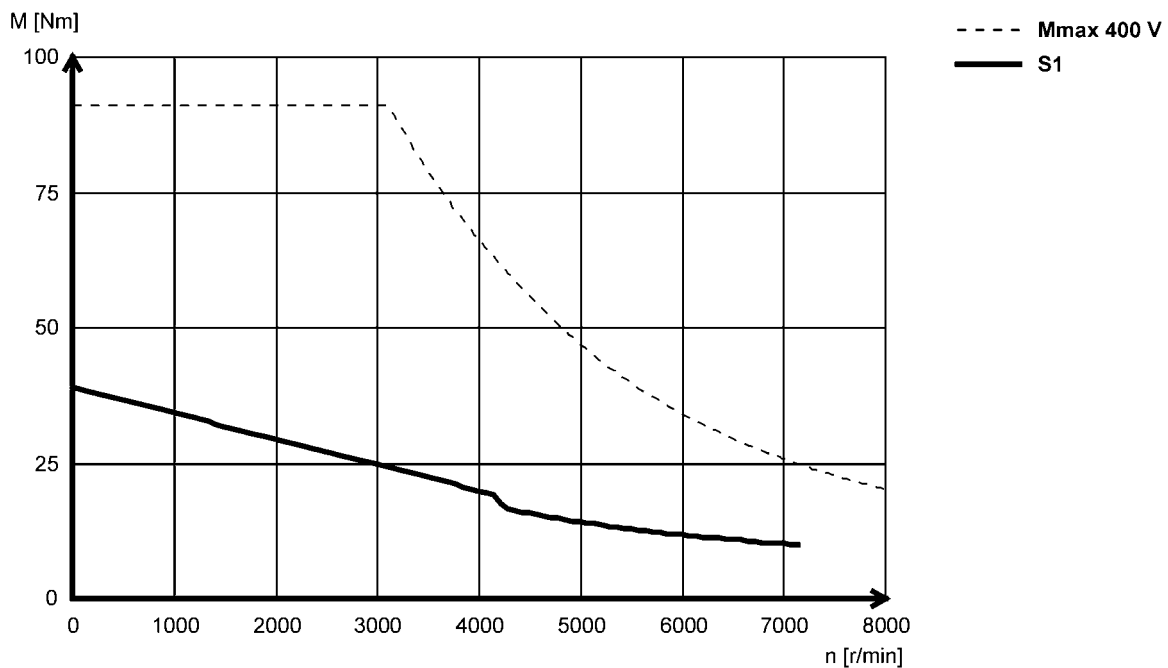

MCA asynchronous servo motors

Technical data



Torque characteristics

- ▶ The data applies to a mains connection voltage of 3 x 400 V.
- ▶ You can find further torque characteristics at www.lenze.de/dsc.

MCA22P08...5F□□ (forced ventilated)

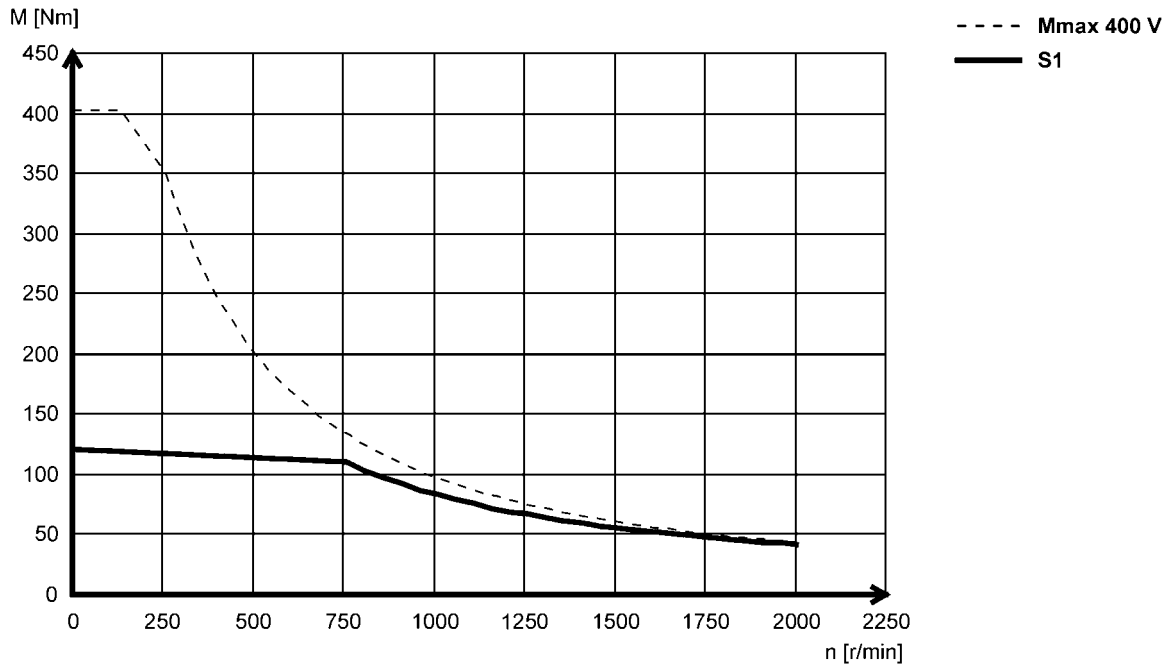

MCA22P08...2F□□ (forced ventilated)

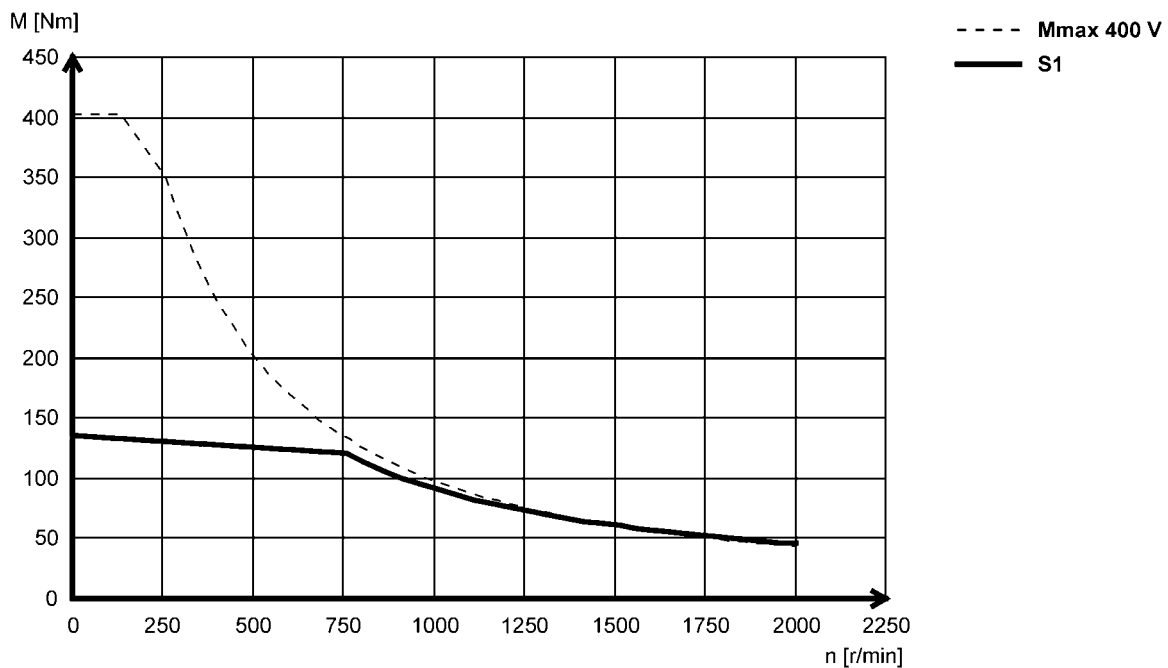

6.11

MCA asynchronous servo motors

Technical data



Torque characteristics

- ▶ The data applies to a mains connection voltage of 3 x 400 V.
- ▶ You can find further torque characteristics at www.lenze.de/dsc.

MCA22P14...5F□□ (forced ventilated)

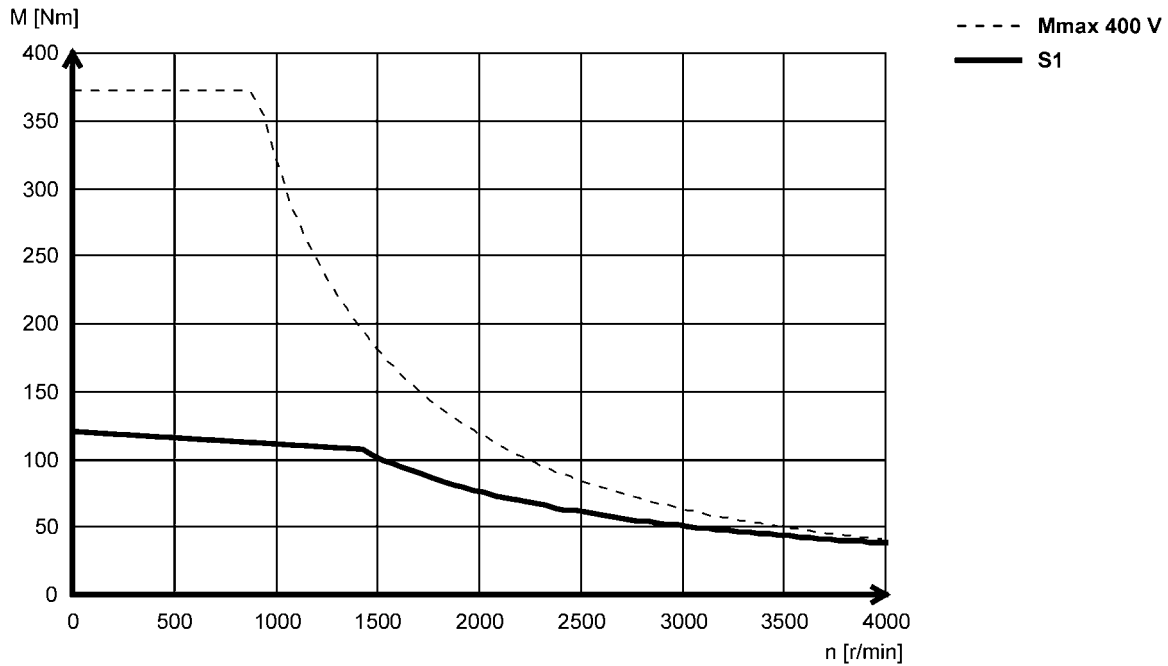

MCA22P14...2F□□ (forced ventilated)

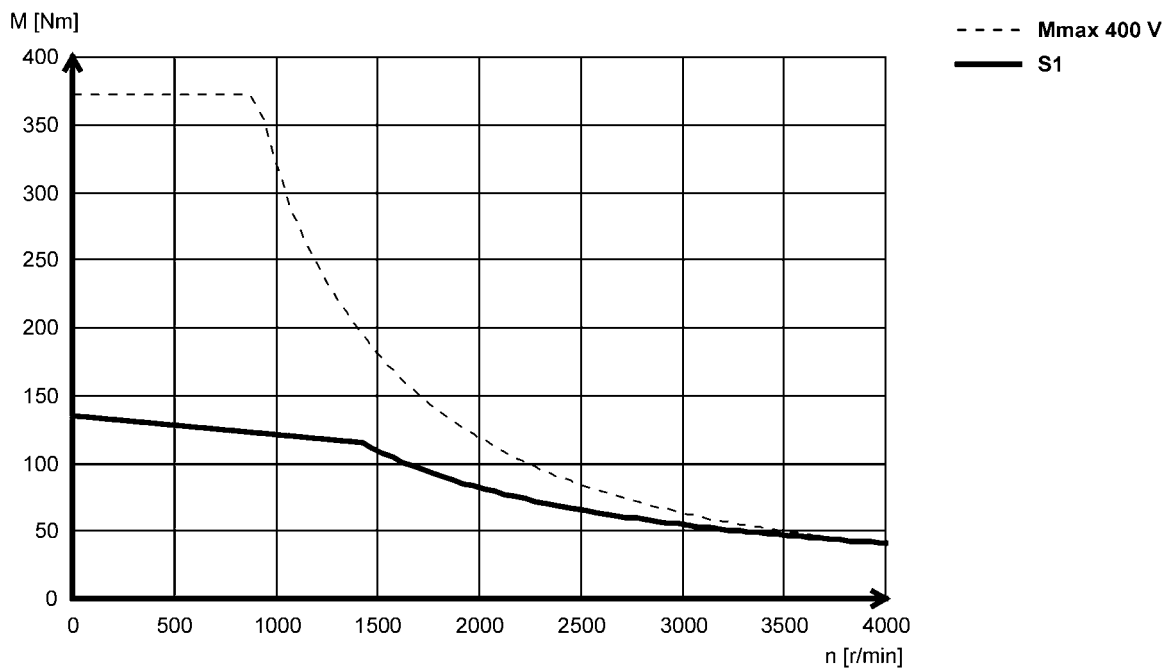

MCA asynchronous servo motors



Technical data

Torque characteristics

- ▶ The data applies to a mains connection voltage of 3 x 400 V.
- ▶ You can find further torque characteristics at www.lenze.de/dsc.

MCA22P17...5F□□ (forced ventilated)

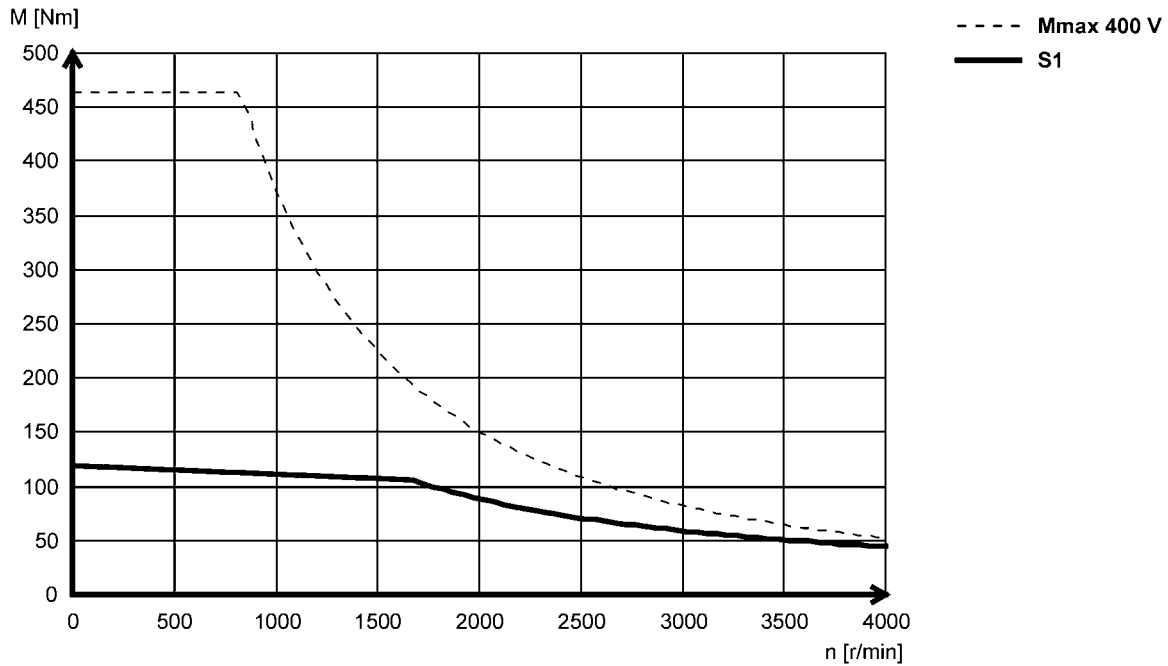

MCA22P17...2F□□ (forced ventilated)

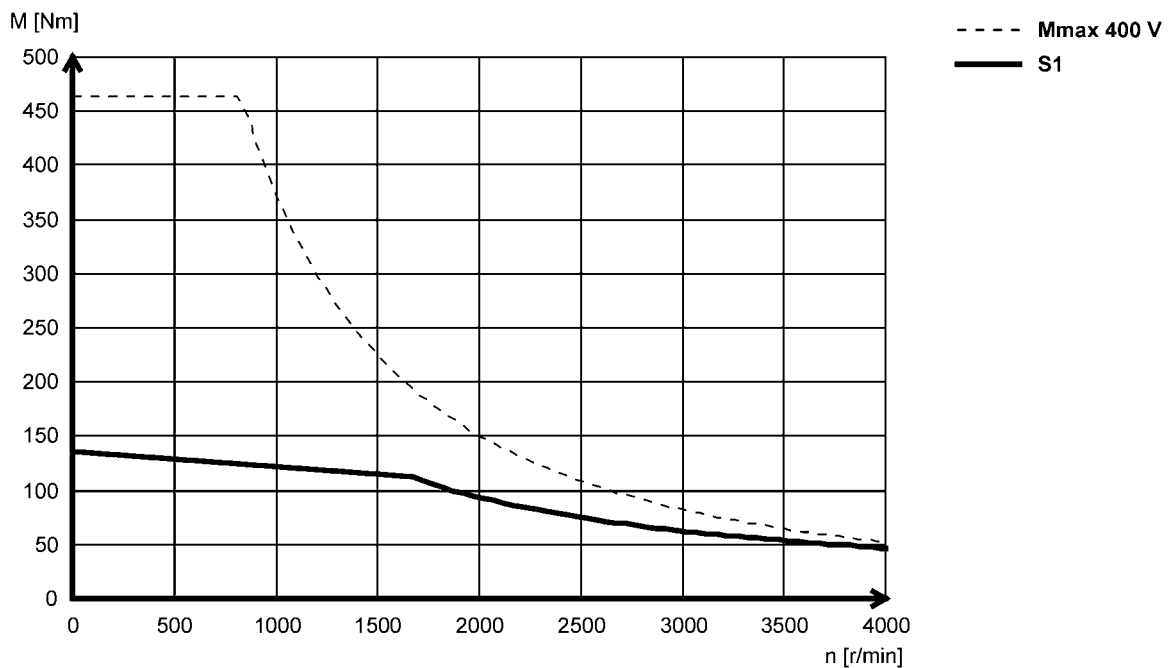

MCA asynchronous servo motors

Technical data



Torque characteristics

- ▶ The data applies to a mains connection voltage of 3 x 400 V.
- ▶ You can find further torque characteristics at www.lenze.de/dsc.

MCA22P29...5F□□ (forced ventilated)

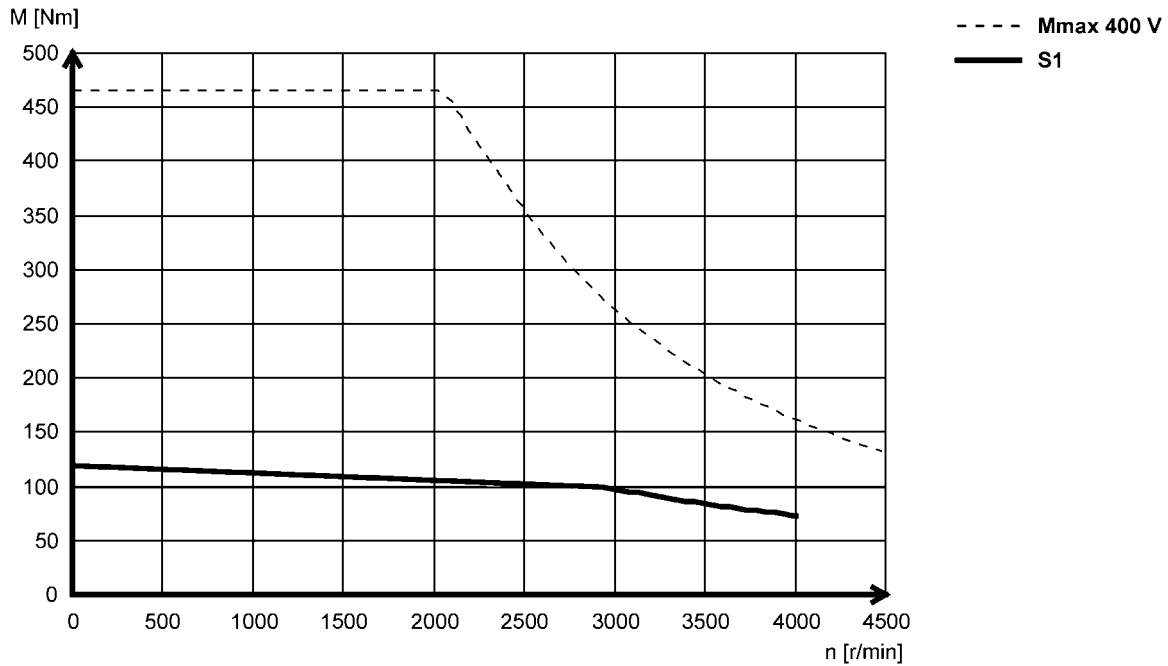

MCA22P29...2F□□ (forced ventilated)

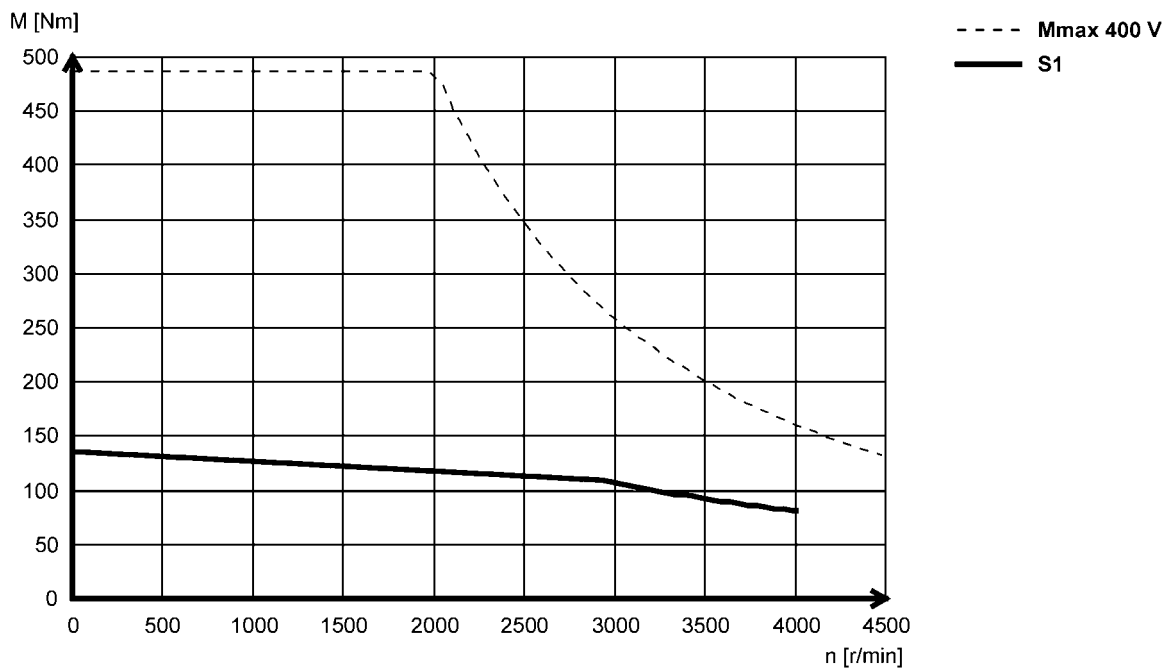

6.11

MCA asynchronous servo motors



Technical data

Torque characteristics

- ▶ The data applies to a mains connection voltage of 3 x 400 V.
- ▶ You can find further torque characteristics at www.lenze.de/dsc.

MCA26T05...5F□□ (forced ventilated)

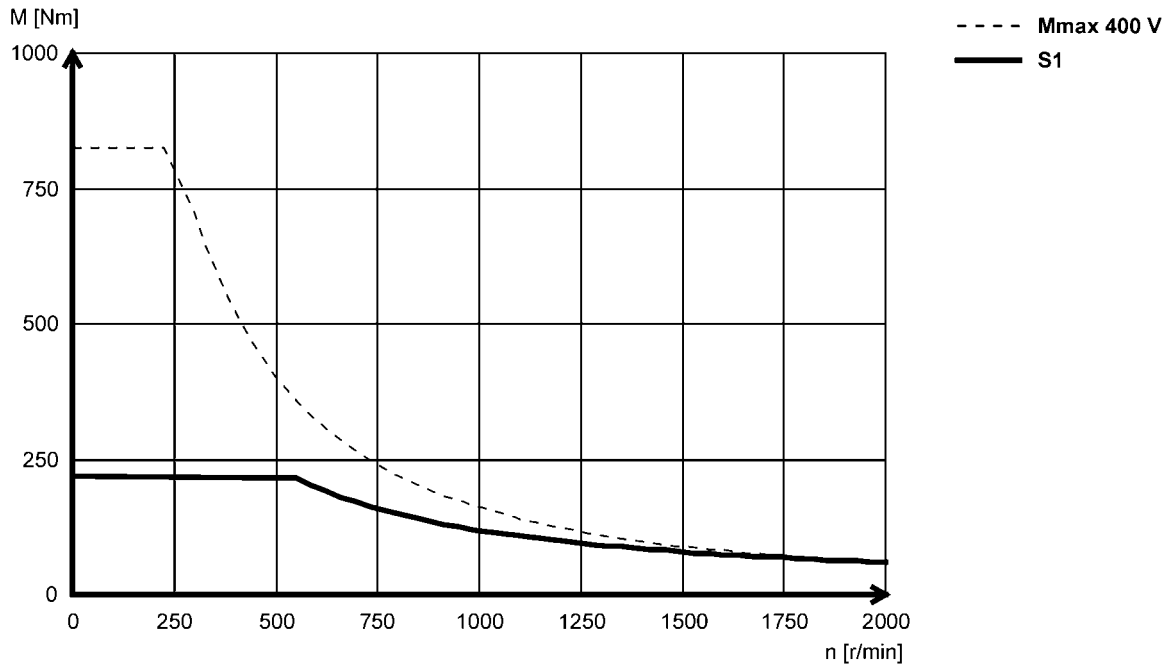

MCA26T05...2F□□ (forced ventilated)

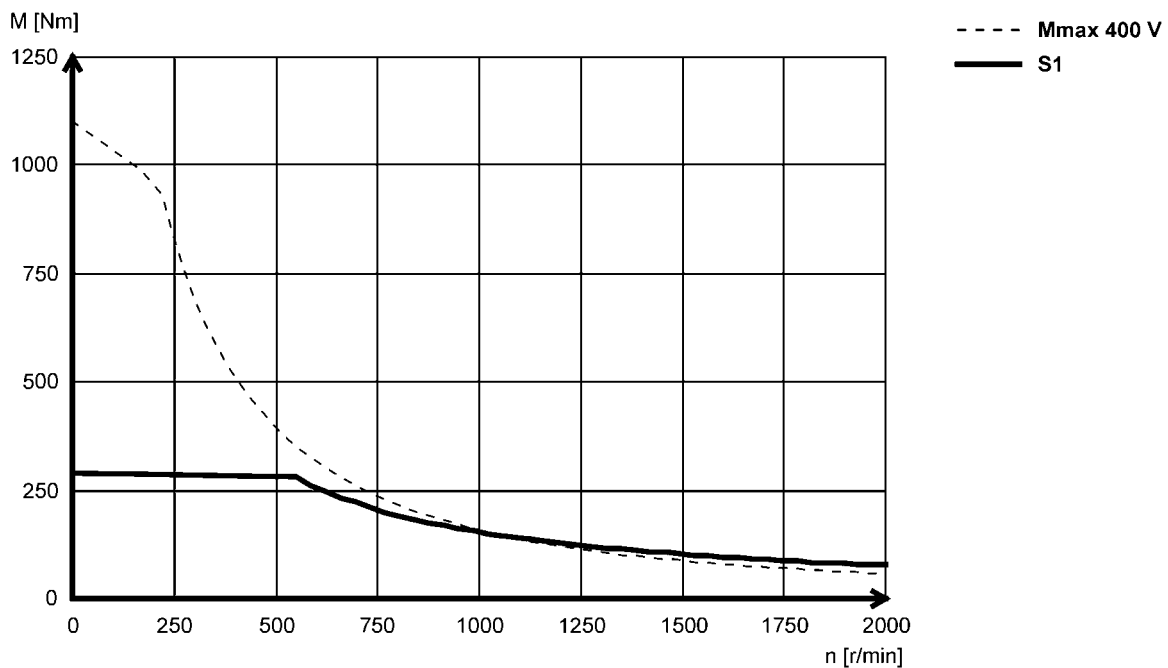

MCA asynchronous servo motors



Technical data

Torque characteristics

- ▶ The data applies to a mains connection voltage of 3 x 400 V.
- ▶ You can find further torque characteristics at www.lenze.de/dsc.

MCA26T10...5F□□ (forced ventilated)

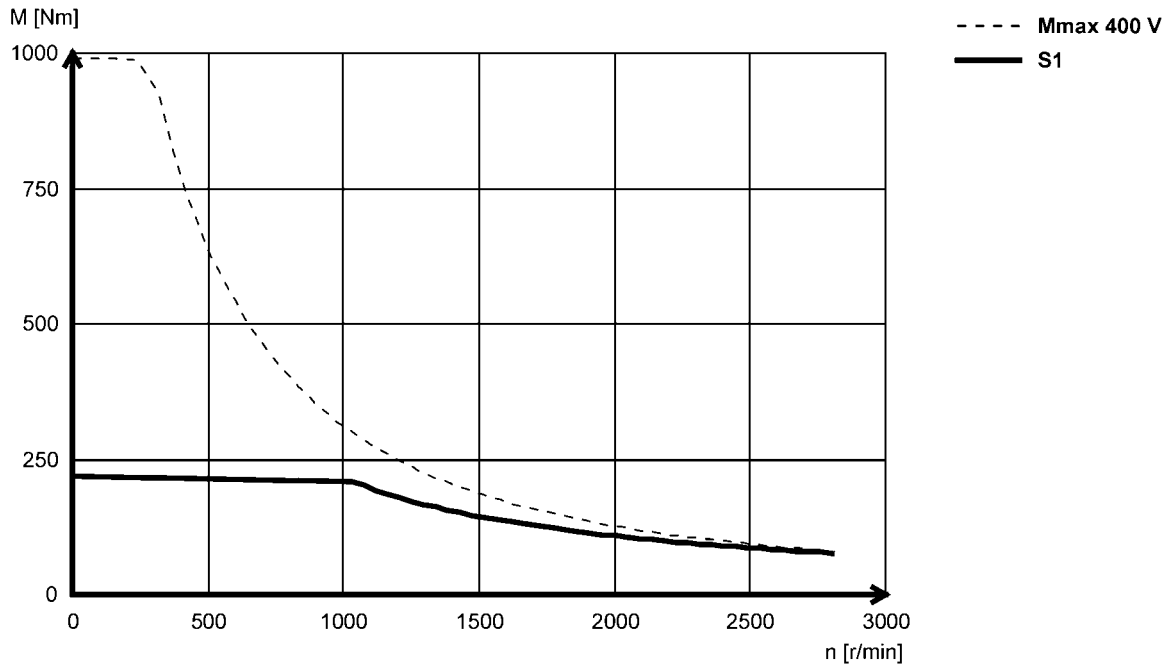

MCA26T10...2F□□ (forced ventilated)

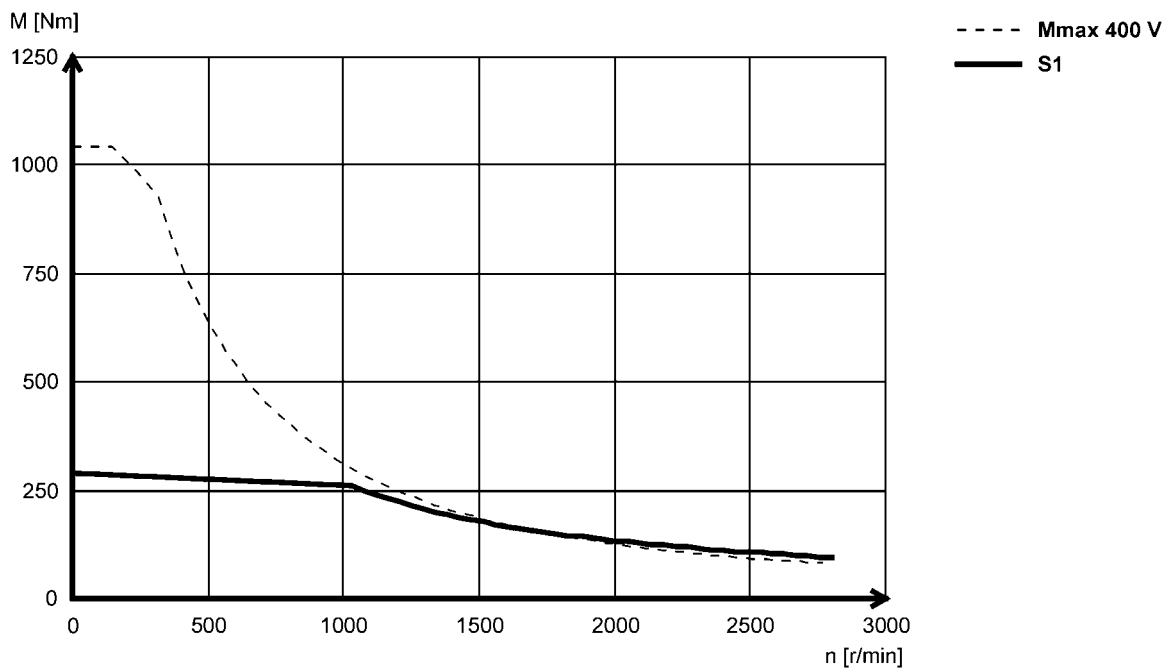

MCA asynchronous servo motors

Technical data

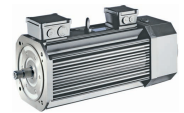

Torque characteristics

- ▶ The data applies to a mains connection voltage of 3 x 400 V.
- ▶ You can find further torque characteristics at www.lenze.de/dsc.

MCA26T12...5F□□ (forced ventilated)

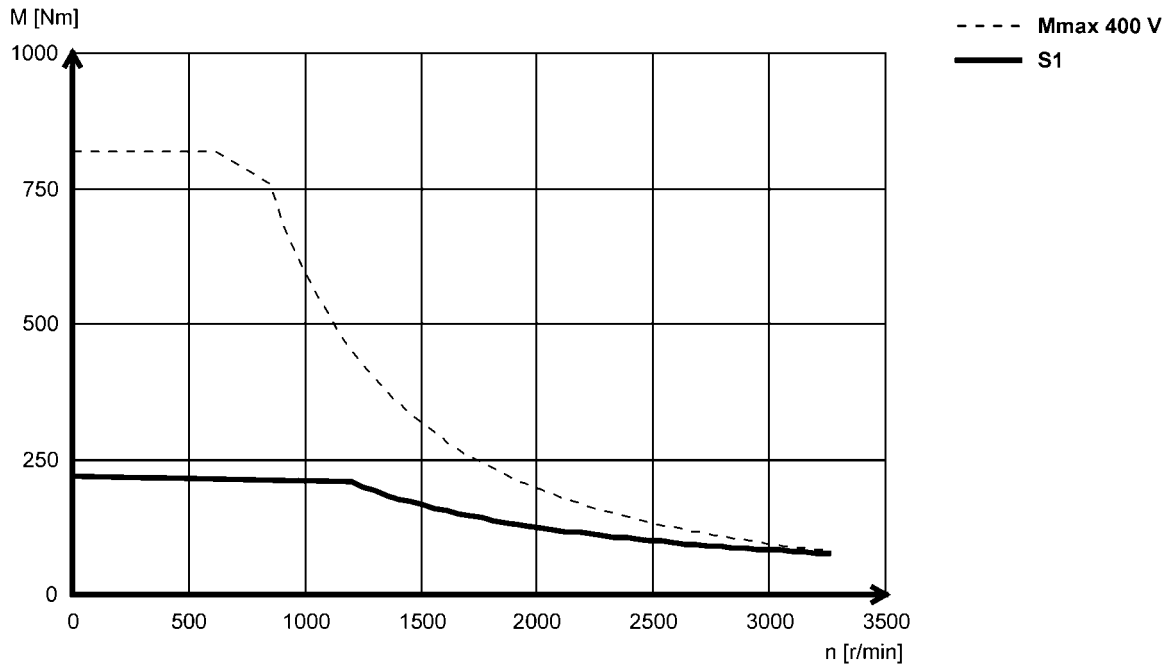

MCA26T12...2F□□ (forced ventilated)

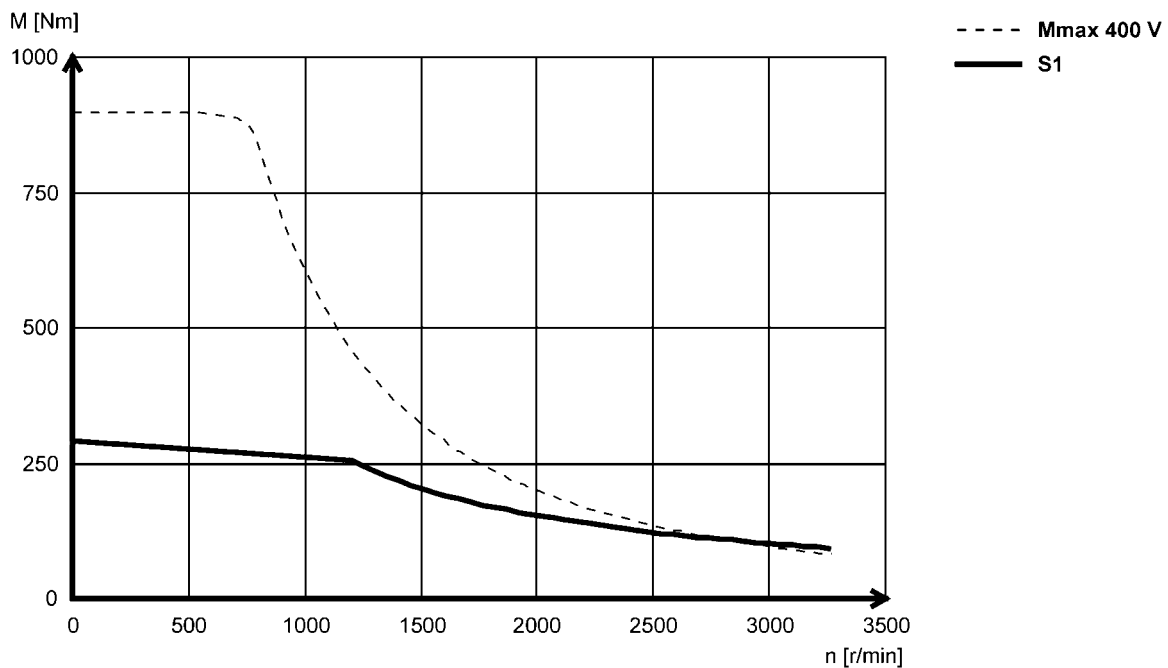

6.11

MCA asynchronous servo motors



Technical data

Torque characteristics

- ▶ The data applies to a mains connection voltage of 3 x 400 V.
- ▶ You can find further torque characteristics at www.lenze.de/dsc.

MCA26T22...5F□□ (forced ventilated)

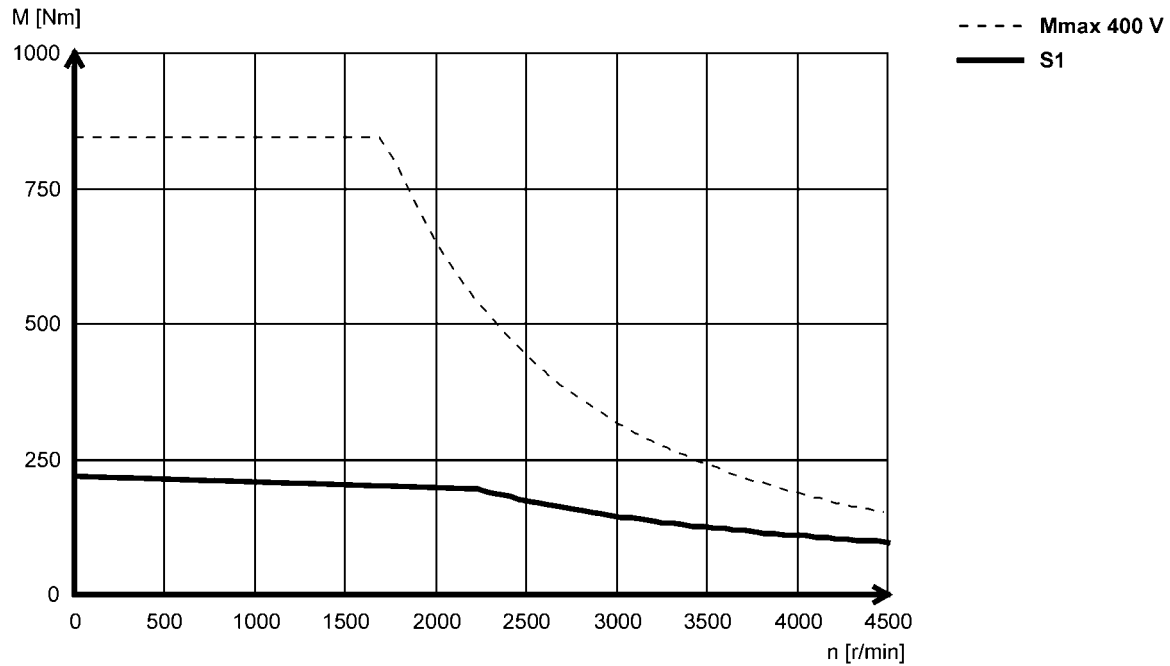

MCA26T22...2F□□ (forced ventilated)

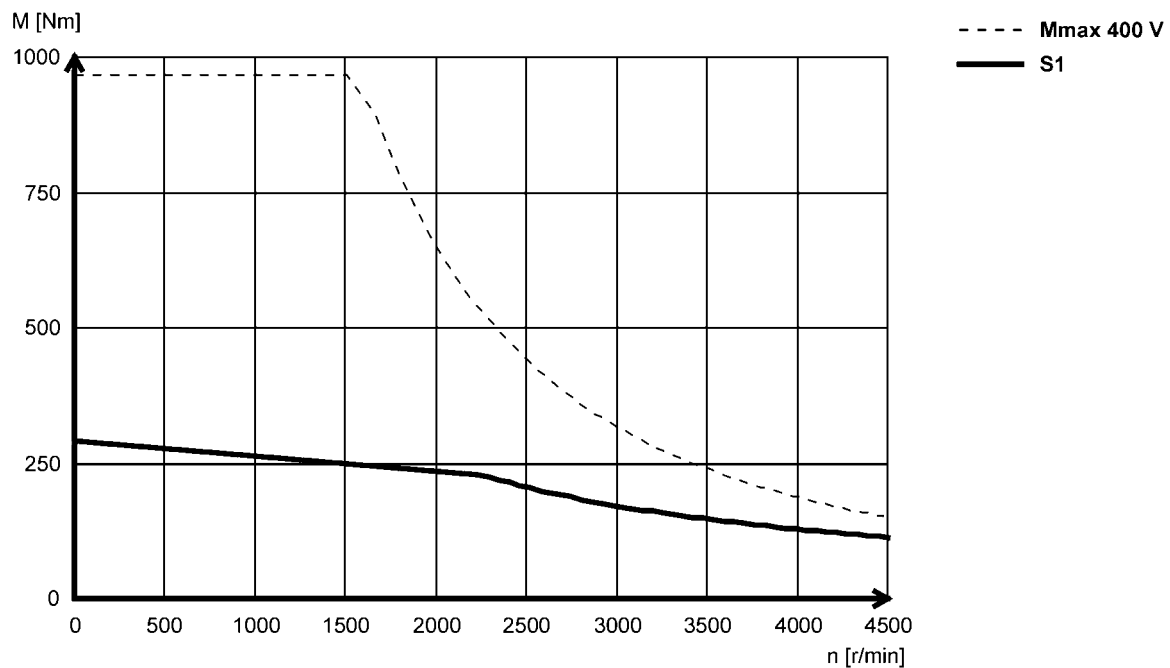

MCA asynchronous servo motors

Technical data



Dimensions, self-ventilated

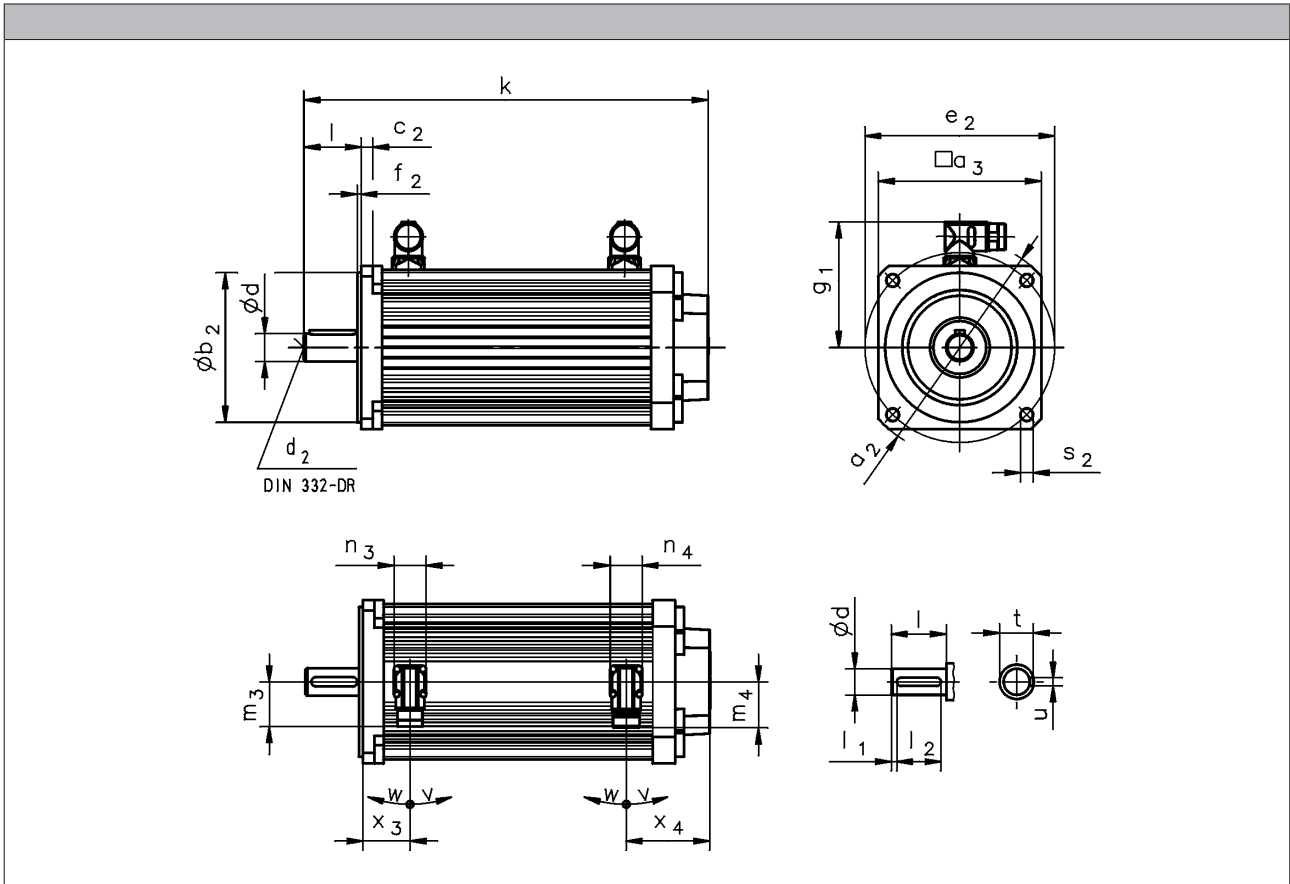

			MCA10I40	MCA13I41	MCA14L20	MCA17N23	MCA19S23	MCA21X25
					MCA14L41	MCA17N41	MCA19S42	MCA21X42
R□O B□	k	[mm]	292	311	352	390	461	550
	x ₃	[mm]	37	45	41	43	56	62
	x ₄	[mm]	61	65	73			78
R□O P□	k	[mm]	317	346	385	425	499	592
	x ₃	[mm]	59	72	68	75	91	102
	x ₄	[mm]	61	65	73			78
S□□ / E□□ / T20 / B□	k	[mm]	346	365	407	444	511	599
	x ₃	[mm]	37	45	41	43	56	62
	x ₄	[mm]	115	119	128	127	123	127
S□□ / E□□ / T20 / P□	k	[mm]	371	400	440	479	549	641
	x ₃	[mm]	59	72	68	75	91	102
	x ₄	[mm]	115	119	128	127	123	127

- ▶ Speed/angle sensor: RS□ / S□□ / E□□ / T20
- ▶ Brake: B□ / P□

MCA asynchronous servo motors

Technical data



Dimensions, self-ventilated

	g_1	n_3	n_4	m_3	m_4	v	w
	[mm]	[mm]	[mm]	[mm]	[mm]	[°]	[°]
MCA10I40	90	28	28	40	40	195	80
MCA13I41	102						
MCA14L20	109						
MCA14L41							
MCA17N23	118	40	71				
MCA17N41							
MCA19S23	151	40	71				
MCA19S42							
MCA21X25	162	40	71				
MCA21X42							

	d	d_2	l	l_1	l_2	u	t
	k_6						
	[mm]	[mm]	[mm]	[mm]	[mm]	[mm]	[mm]
MCA10	14	M5	30	2.5	25	5.0	16.0
MCA13	19	M6	40	2.0	36	6.0	21.5
MCA14	24	M8	50	5.0	40	8.0	27.0
MCA17							
MCA19	28	M10	60		50	31.0	
MCA21	38	M12	80		70	10.0	41.0

	a_2	a_3	b_2	c_2	e_2	f_2	s_2
			j_6				
	[mm]	[mm]	[mm]	[mm]	[mm]	[mm]	[mm]
MCA10	120	102	80	8	100	3.0	7
			70		85	2.5	M6
MCA13	160	130	110	9	130	3.5	9.0
							M8
MCA14	188	142	130	10	165	3.5	11.0
			110				130
MCA17	200	165	130	12	165	3.5	11.0
			110				130
MCA19	250	192	180	11	215	4.0	13.0
			110		130	3.5	M8
MCA21	300	250	230	12	215	4.0	13.0
			110		130		
MCA21	250	214	110	11	130	3.5	M8

MCA asynchronous servo motors

Technical data



Dimensions, forced ventilated

Motors MCA13 to 19/21

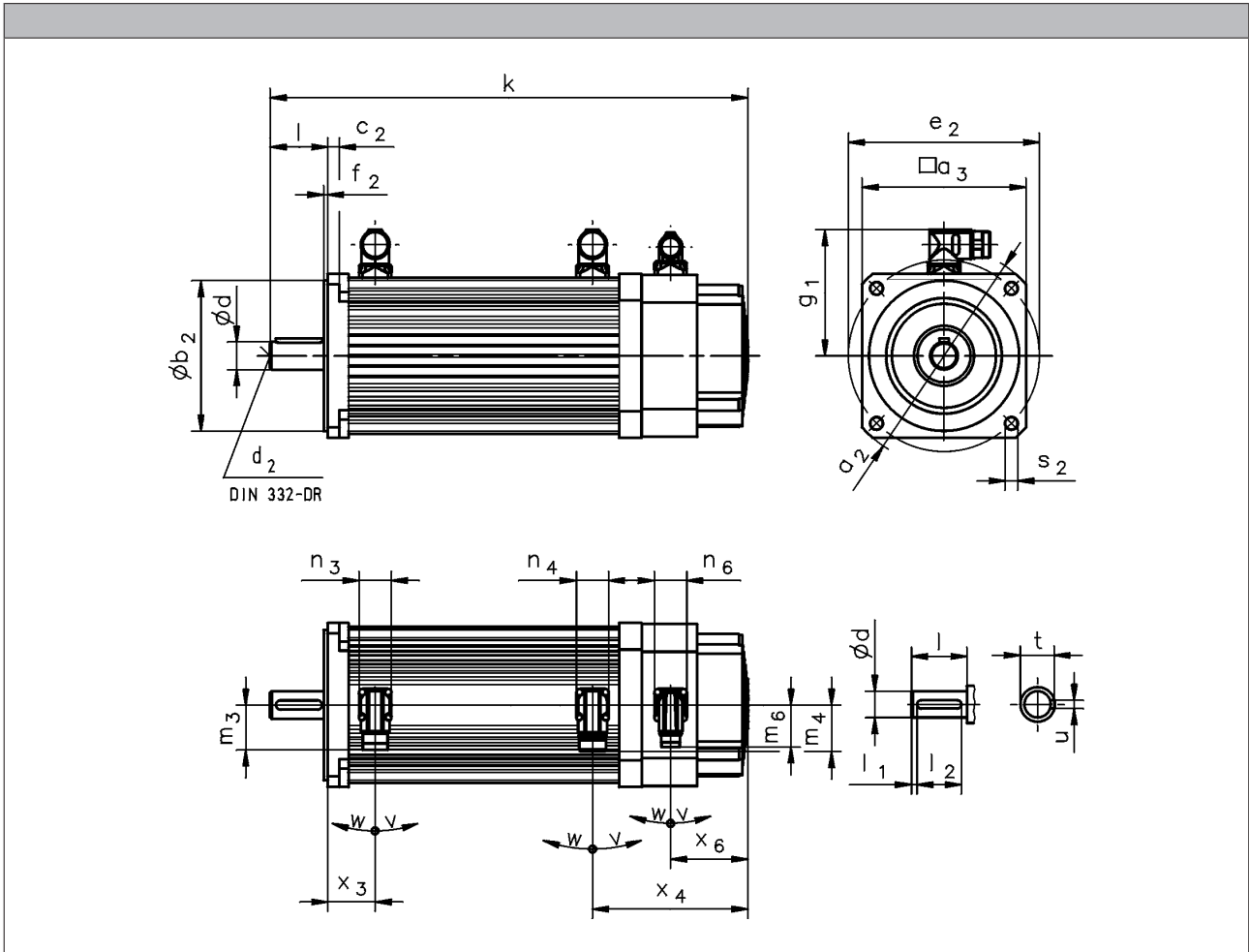

			MCA13I34	MCA14L16	MCA17N17	MCA19S17	MCA21X17
				MCA14L35	MCA17N35	MCA19S35	MCA21X35
R□0 B0	k	[mm]	379	414	476	558	646
	x ₃	[mm]	45	41	43	56	62
	x ₄	[mm]	133	135	159	170	174
R□0 P□	k	[mm]	414	447	511	596	688
	x ₃	[mm]	72	68	75	91	102
	x ₄	[mm]	133	135	159	170	174
S□□ / E□□ / T20 / B0	k	[mm]	433	469	530	608	695
	x ₃	[mm]	45	41	43	56	62
	x ₄	[mm]	187	190	213	220	223
S□□ / E□□ / T20 / P□	k	[mm]	468	502	565	646	737
	x ₃	[mm]	72	68	75	91	102
	x ₄	[mm]	187	190	213	220	223
	x ₆	[mm]	73	67	94	103	96

- ▶ Speed/angle sensor: RS0 / S□□ / E□□ / T20
- ▶ Brake: B0 / P□

MCA asynchronous servo motors

Technical data



Dimensions, forced ventilated

Motors MCA13 to 19/21

	g ₁	n ₃	n ₄	n ₆	m ₃	m ₄	m ₆	v	w
	[mm]	[mm]	[mm]	[mm]	[mm]	[mm]	[mm]	[°]	[°]
MCA13I34	102	28	28	28	40	40	37	195	80
MCA14L16	109								
MCA14L35	118								
MCA17N17	118								
MCA17N35	151	40			71				
MCA19S17	151								
MCA19S35	162								
MCA21X17	162								
MCA21X35	162								

	d	d ₂	l	l ₁	l ₂	u	t
	k6						
	[mm]	[mm]	[mm]	[mm]	[mm]	[mm]	[mm]
MCA13	19	M6	40	2.0	36	6.0	21.5
MCA14	24	M8	50	5.0	40	8.0	27.0
MCA17					50		31.0
MCA19	28	M10	60		70	10.0	41.0
MCA21	38	M12	80				

	a ₂	a ₃	b ₂	c ₂	e ₂	f ₂	s ₂
			j6				
	[mm]	[mm]	[mm]	[mm]	[mm]	[mm]	[mm]
MCA13	160	130	110	9	130	3.5	9.0
			M8				
MCA14	188	142	130	10	165		11.0
			110		130		M8
MCA17	200	165	130	12	165	11.0	
			110		130	M8	
MCA19	250	192	180	11	215	4.0	13.0
			110		130	3.5	M8
MCA21		214	180		215	4.0	13.0
	300	250	230	12	265		
	250	214	110	11	130	3.5	M8

MCA asynchronous servo motors

Technical data



Dimensions, forced ventilated

MCA20/22/26 motors in B3 design

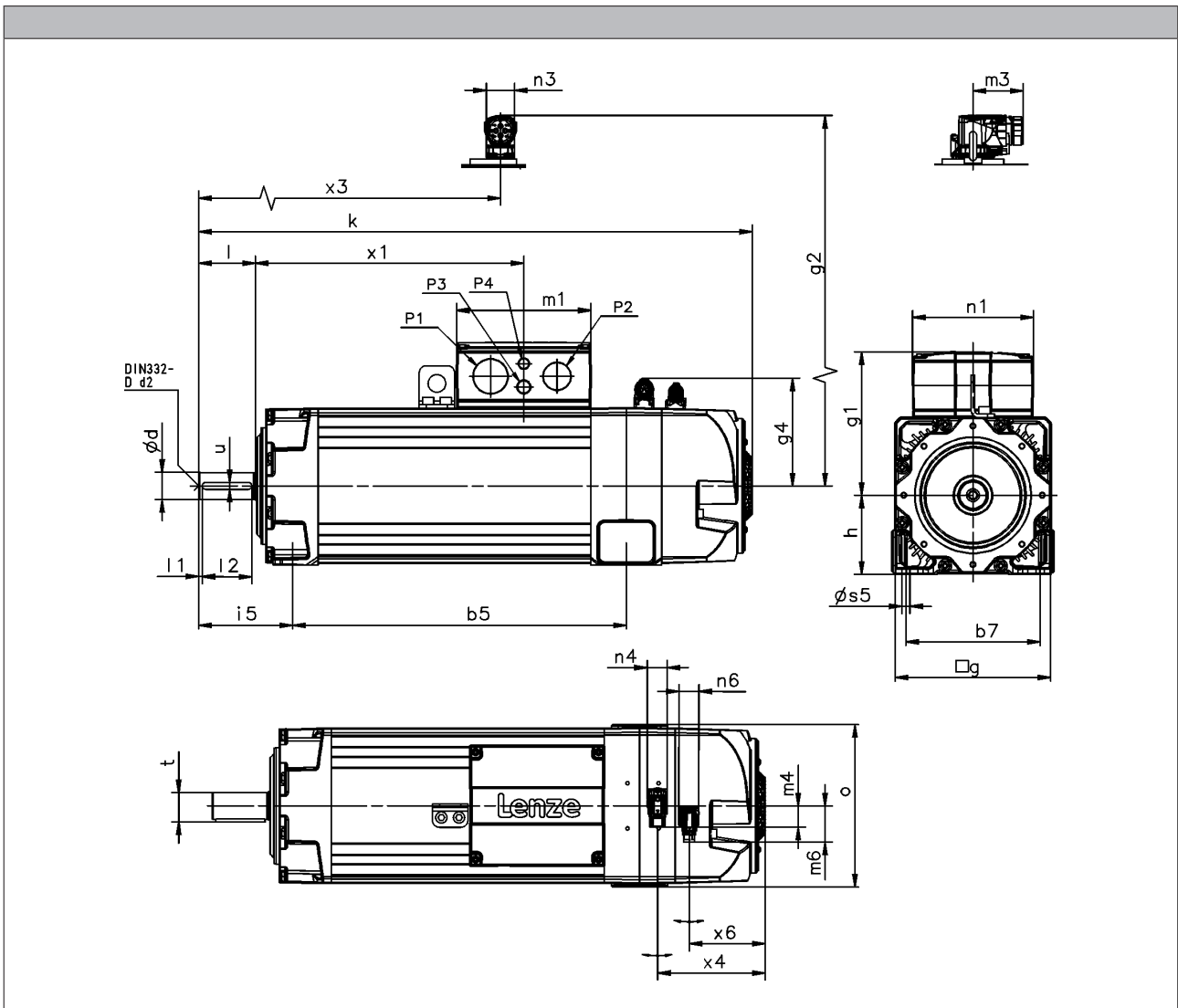

			MCA20	MCA22	MCA26
R□□ / E□□ / T□□ / S□□ / B0...F10	k	[mm]	666	783	970
R□□ / E□□ / T□□ / S□□ / B0...F1F	k	[mm]	754	865	1022
R□□ / E□□ / T□□ / S□□ / B0	x ₄	[mm]	146	153	194
	m ₄	[mm]	25.0	31.0	25.0
R□□ F1...F10	k	[mm]	753	878	1125
R□□ F1...F1F	k	[mm]	842	959	1177
R□□ F1	x ₄	[mm]	151	157	201
	m ₄	[mm]		31.0	
E□□ / T□□ / S□□ / F1...F10	k	[mm]	797	916	1163
E□□ / T□□ / S□□ / F1...F1F	k	[mm]	885	998	1215
E□□ / T□□ / S□□ / F1	x ₄	[mm]	146	162	200
	m ₄	[mm]		31.0	
R□□ / E□□ / T□□ / S□□ / F2...F10	k	[mm]	822	948	1163
R□□ / E□□ / T□□ / S□□ / F2...F1F	k	[mm]	910	1030	1215
R□□ / E□□ / T□□ / S□□ / F2	x ₄	[mm]	146	162	200
	m ₄	[mm]		31.0	

6.11

MCA asynchronous servo motors

Technical data



Dimensions, forced ventilated

MCA20/22/26 motors in B3 design

	g	g ₁	g ₂	g ₄	m ₁	m ₃	m ₆	n ₁	n ₃	n ₄	n ₆
	[mm]	[mm]	[mm]	[mm]	[mm]	[mm]	[mm]	[mm]	[mm]	[mm]	[mm]
MCA20	200	171	168	141	154	72	51	128	40	28	28
MCA22	220	203		153	190			171			
MCA26	260	256		173	234			212			

	o	P ₁	P ₂	P ₃	P ₄	x ₁	x ₃	x ₆
	[mm]	[mm]	[mm]	[mm]	[mm]	[mm]	[mm]	[mm]
MCA20	206	M32x1.5	M25x1.5	M20x1.5	M16x1.5	299	422	101
MCA22	230	M50x1.5	M40x1.5			380		108
MCA26	269	M63x1.5	M50x1.5			465		152

	d	d	d ₂	l	l ₁	l ₂	u	t
	k6	m6		-0.7 ... 0.3				
	[mm]	[mm]	[mm]		[mm]	[mm]	[mm]	[mm]
MCA20	38		M12	80	5.0	70	10.0	41.0
MCA22								
MCA26		55	M20	110			100	16.0

	h	b ₅	b ₇	s ₅	i ₅
	[mm]	[mm]	[mm]	[mm]	[mm]
MCA20	100	366	160	11.5	134
MCA22	112	472	190		133
MCA26	132	581	215	14.0	165

- ▶ Speed/angle sensor: RS0 / S□□ / E□□ / T□□
- ▶ Brake: B0 / F1 / F2
- ▶ Blower: F10 / F1F

MCA asynchronous servo motors

Technical data



Dimensions, forced ventilated

MCA20/22/26 motors in B35 design

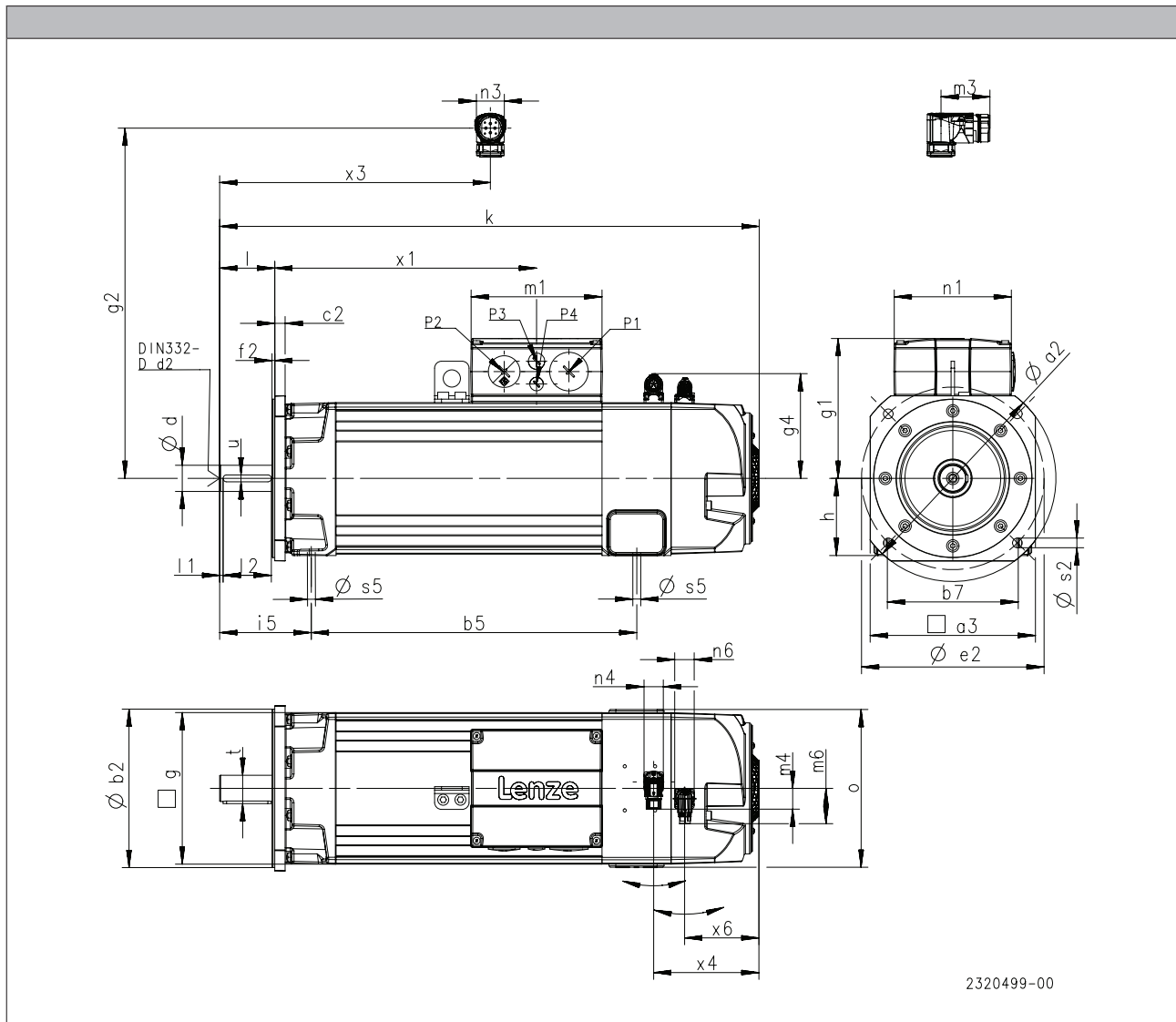

			MCA20	MCA22	MCA26
R□□ / E□□ / T□□ / S□□ / B0...F10	k	[mm]	666	783	970
R□□ / E□□ / T□□ / S□□ / B0...F1F	k	[mm]	754	865	1022
R□□ / E□□ / T□□ / S□□ / B0	x ₄	[mm]	146	153	194
	m ₄	[mm]	25.0	31.0	25.0
R□□ F1...F10	k	[mm]	753	878	1125
R□□ F1...F1F	k	[mm]	842	959	1177
R□□ F1	x ₄	[mm]	151	157	201
	m ₄	[mm]		31.0	
E□□ / T□□ / S□□ / F1...F10	k	[mm]	797	916	1163
E□□ / T□□ / S□□ / F1...F1F	k	[mm]	885	998	1215
E□□ / T□□ / S□□ / F1	x ₄	[mm]	146	162	200
	m ₄	[mm]		31.0	
R□□ / E□□ / T□□ / S□□ / F2...F10	k	[mm]	822	948	1163
R□□ / E□□ / T□□ / S□□ / F2...F1F	k	[mm]	910	1030	1215
R□□ / E□□ / T□□ / S□□ / F2	x ₄	[mm]	146	162	200
	m ₄	[mm]		31.0	

6.11

MCA asynchronous servo motors

Technical data



Dimensions, forced ventilated

MCA20/22/26 motors in B35 design

	g	g ₁	g ₂	g ₄	m ₁	m ₃	m ₆	n ₁	n ₃	n ₄	n ₆
	[mm]	[mm]	[mm]	[mm]	[mm]	[mm]	[mm]	[mm]	[mm]	[mm]	[mm]
MCA20	200	171	168	141	154	72	51	128	40	28	28
MCA22	220	203		153	190			171			
MCA26	260	256		173	234			212			

	o	P ₁	P ₂	P ₃	P ₄	x ₁	x ₃	x ₆
	[mm]	[mm]	[mm]	[mm]	[mm]	[mm]	[mm]	[mm]
MCA20	206	M32x1.5	M25x1.5	M20x1.5	M16x1.5	299	422	101
MCA22	230	M50x1.5	M40x1.5			380		108
MCA26	269	M63x1.5	M50x1.5			465		152

	d	d	d ₂	l	l ₁	l ₂	u	t
	k6	m6		-0.7 ... 0.3				
	[mm]	[mm]	[mm]		[mm]	[mm]	[mm]	[mm]
MCA20	38		M12	80	5.0	70	10.0	41.0
MCA22								
MCA26		55	M20	110		100	16.0	59.0

	h	b ₅	b ₇	s ₅	i ₅
	[mm]	[mm]	[mm]	[mm]	[mm]
MCA20	100	366	160	11.5	134
MCA22	112	472	190		133
MCA26	132	581	215	14.0	165

	a ₂	a ₃	b ₂	b ₂	c ₂	e ₂	f ₂	s ₂
			j6	h6				
	[mm]	[mm]	[mm]	[mm]	[mm]	[mm]	[mm]	[mm]
MCA20	250	196	180		15	215	4.0	14
MCA22	300	240	230			265		
MCA26	400	320				300	350	5.0

- ▶ Speed/angle sensor: RS0 / S□□ / E□□ / T□□
- ▶ Brake: B0 / F1 / F2
- ▶ Blower: F10 / F1F

MCA asynchronous servo motors

Technical data





Permanent magnet holding brake

The asynchronous servo motors MCA10 to 19 and 21 can be fitted with integral permanent magnet holding brakes. In the case of permanent magnet brakes, the rated torque applies solely as holding torque at standstill. This is due to the nature of their design. During braking from full motor speed, e.g. in the event of emergency stops, the braking torque is significantly reduced. As such, they may not be used as safety elements (particularly with lifting axes) without additional measures being implemented. The brakes are activated when the supply voltage is disconnected (closed-circuit principle). When using the brakes purely as holding brakes, virtually no wear occurs on the friction surfaces.

For traversing axes, adherence to the permissible load/brake motor (J_L / J_{MB}) moment of inertia ensures that the permissible maximum switching rate of the brake will not be exceeded and at least 2,000 emergency stop functions can be performed from a speed of 3,000 rpm.

For lifting axes, the load torque resulting from the weight acts additionally. In this case the specifications for J_L / J_{MB} do not apply.

Caution:

The brakes used are not safety brakes in the sense that a reduction in torque may arise as a result of disruptive factors that cannot be influenced, e.g. oil ingress.

The ohmic voltage drop along the cable must be taken into consideration in long motor supply cables and must be compensated for by a higher voltage at the line input.

The following applies for Lenze system cables:

$$U[V] = U_B[V] + 0.08 \frac{[V]}{[A] \cdot [m]} \cdot l_{lg}[m] \cdot I_B[A]$$

If no suitable voltage (incorrect value, incorrect polarity) is applied to the brake, the brake will be applied and can be overheated and destroyed by the motor continuing to rotate.

The shortest switching times of the brakes are achieved by DC switching of the voltage. A spark suppressor is required to suppress interference and to increase the service life of the relay contacts here.



Permanent magnet holding brake



Permanent magnet holding brake

Rated data with standard braking torque

- The figures stated apply to servo motors. They only apply to geared servo motors when the servo motor is connected via a mounting flange.

	$U_{N,DC}^{3,4,7)}$	$U_{N,AC}^{5,7)}$	M_N	M_N	M_{av}	$I_N^{2)}$	J	$t_1^{1)}$	$t_2^{1)}$	$Q_E^{6)}$	m	J_{MB}	J_L/J_{MB}
	[V]	[V]	20 °C	120 °C	120 °C	[A]	[kgcm ²]	[ms]	[ms]	[J]	[kg]	[kgcm ²]	
MCA10	24		3.30	2.50	1.20	0.50	0.38	10.0	20.0	350	0.90	2.78	24.5
	205					0.060							
MCA13	24		12.0	11.0	5.50	0.67	1.06	20.0	29.0	400	0.80	9.36	7.70
	205					0.080							
MCA14	24		15.0	12.0	6.00	0.75	3.60	13.0	30.0	700	1.50	22.8	5.20
	205					0.090							
MCA17	24		24.0	22.0	11.0	0.75	9.50	25.0	50.0	1200	2.70	81.5	3.70
	205					0.090							
MCA19	24		46.0	40.0	18.0	1.00	31.8	53.0	97.0	2800	5.00	212	1.70
	205					0.12							
MCA21	24		88.0	80.0	35.0	1.46	31.8	53.0	97.0	2800	5.00	212	1.70
	205					0.18							

- ¹⁾ Engagement and disengagement times are valid for rated voltage ($\pm 0\%$) and protective circuit for brakes with varistor for DC switching. The times may increase without a protective circuit.
- ²⁾ The currents are the maximum values when the brake is cold (value used for dimensioning the current supply). The values for a motor at operating temperature are considerably lower.
- ³⁾ With 24 V DC brake: smoothed DC voltage, ripple $\leq 1\%$.
With 205 V DC brake: connection to 230 V AC through rectifier.
- ⁴⁾ UR not possible in the case of a brake with a 205 V supply voltage.
- ⁵⁾ UR not possible in the case of a brake with 230 V supply voltage.
- ⁶⁾ Maximum switching energy per emergency stop at $n = 3000$ r/min for at least 2000 emergency stops.
- ⁷⁾ Voltage tolerance: permanent magnet brakes -10% to $+5\%$
spring-applied brakes $\pm 10\%$



Permanent magnet holding brake

Rated data with increased braking torque

- These ratings apply only for geared servo motors with integrated servo motor (without mounting flange).

	U _{N,DC} ^{3,4,7)}	M _N	M _N	M _{av}	I _N ²⁾	J	t ₁ ¹⁾	t ₂ ¹⁾	Q _E ⁶⁾	m	J _{MB}	J _L /J _{MB}
		20 °C	120 °C	120 °C								
	[V]	[Nm]	[Nm]	[Nm]	[A]	[kgcm ²]	[ms]	[ms]	[J]	[kg]	[kgcm ²]	
MCA10	24	6.00	5.00	2.50	0.67	1.06	20.0	29.0	400	0.80	3.46	22.4
	205				0.80							
MCA13	24	15.0	12.0	6.00	0.75	3.60	13.0	30.0	700	1.50	11.9	8.40
	205				0.090							
MCA14	24	23.0	20.0	20.0	0.92	9.50	18.0	55.0	1350	2.40	22.8	6.60
	205				0.12							
MCA17	24				0.92						45.5	5.00
	205											
MCA19	24	48.0	40.0	31.8	1.46	30.0	100	2800	4.80	104	4.50	
	205				0.18							
MCA21	24	88.0	80.0	35.0	1.46	53.0	97.0	2800	5.00	212	1.70	
	205				0.18							

- 1) Engagement and disengagement times are valid for rated voltage ($\pm 0\%$) and protective circuit for brakes with varistor for DC switching. The times may increase without a protective circuit.
- 2) The currents are the maximum values when the brake is cold (value used for dimensioning the current supply). The values for a motor at operating temperature are considerably lower.
- 3) With 24 V DC brake: smoothed DC voltage, ripple $\leq 1\%$.
With 205 V DC brake: connection to 230 V AC through rectifier.
- 4) UR not possible in the case of a brake with a 205 V supply voltage.
- 5) UR not possible in the case of a brake with 230 V supply voltage.
- 6) Maximum switching energy per emergency stop at $n = 3000$ r/min for at least 2000 emergency stops.
- 7) Voltage tolerance: permanent magnet brakes -10% to +5%
spring-applied brakes $\pm 10\%$



Spring-applied holding brake

Spring-operated holding brakes are available for the asynchronous servo motors MCA20, 22 and 26.

The brakes are activated when the supply voltage is disconnected (closed-circuit principle). When using the brakes purely as holding brakes, virtually no wear occurs on the friction surfaces.

Caution:

The brakes used are not safety brakes in the sense that a reduction in torque may arise as a result of disruptive factors that cannot be influenced, e.g. oil ingress.

The ohmic voltage drop along the cable must be taken into consideration in long motor supply cables and must be compensated for by a higher voltage at the line input.

The following applies for Lenze system cables:

$$U[V] = U_B[V] + 0.08 \frac{[V]}{[A] \cdot [m]} \cdot l_{lg}[m] \cdot I_B[A]$$

If no suitable voltage (incorrect value, incorrect polarity) is applied to the brake, the brake will be applied and can be overheated and destroyed by the motor continuing to rotate.

The shortest switching times of the brakes are achieved by DC switching of the voltage. A spark suppressor is required to suppress interference and to increase the service life of the relay contacts here.



Spring-applied holding brake



Spring-applied holding brake

Rated data with standard braking torque

- The figures stated apply to servo motors. They only apply to geared servo motors when the servo motor is connected via a mounting flange.

	$U_{N,DC}^{3,4,7)}$	$U_{N,AC}^{5,7)}$	M_N	M_N	M_{av}	$I_N^{2)}$	J	$t_1^{1)}$	$t_2^{1)}$	$Q_E^{6)}$	m	J_{MB}	J_L/J_{MB}
	[V]	[V]	[Nm]	[Nm]	[Nm]	[A]	[kgcm ²]	[ms]	[ms]	[J]	[kg]	[kgcm ²]	
MCA20	24	230	90.0	80.0	50.0	3.13	6.88	70.0	220	18000	13.0	177	19.6
	0.37												
MCA22	24	230	150	130	80.0	3.75	18.1	50.0	260	23000	20.5	505	8.20
	0.44					130							
MCA26	24	230	300	260	160	3.75	36.3	175	320	39000	26.0	1405	12.7
	0.37				70.4	360			51000				

Rated data with increased braking torque

- The figures stated apply to servo motors. They only apply to geared servo motors when the servo motor is connected via a mounting flange.

	$U_{N,DC}^{3,4,7)}$	$U_{N,AC}^{5,7)}$	M_N	M_N	M_{av}	$I_N^{2)}$	J	$t_1^{1)}$	$t_2^{1)}$	$Q_E^{6)}$	m	J_{MB}	J_L/J_{MB}
	[V]	[V]	[Nm]	[Nm]	[Nm]	[A]	[kgcm ²]	[ms]	[ms]	[J]	[kg]	[kgcm ²]	
MCA20	24	230	150	130	100	2.58	14.1	70.0	240	31000	15.4	189	33.0
	0.30												
MCA22	24	230	300	260	160	3.75	36.3	175	320	39000	26.0	523	14.1
	0.44					130		310					
MCA26	24	230	500	430	260	3.75	70.4	175	390	51000	30.8	1405	12.7
	0.44												

- Engagement and disengagement times are valid for rated voltage ($\pm 0\%$) and protective circuit for brakes with varistor for DC switching. The times may increase without a protective circuit.
- The currents are the maximum values when the brake is cold (value used for dimensioning the current supply). The values for a motor at operating temperature are considerably lower.
- With 24 V DC brake: smoothed DC voltage, ripple $\leq 1\%$.
With 205 V DC brake: connection to 230 V AC through rectifier.
- UR not possible in the case of a brake with a 205 V supply voltage.
- UR not possible in the case of a brake with 230 V supply voltage.
- Maximum switching energy per emergency stop at $n = 3000$ r/min for at least 2000 emergency stops.
- Voltage tolerance: permanent magnet brakes -10% to +5%
spring-applied brakes $\pm 10\%$



Resolver

Stator-fed resolver with two stator windings offset by 90° and one rotor winding with transformer winding.

Speed/angle sensor				RS0	RV0
	1)				
Product key				RS0	RV03
Resolution					
Angle			[°]	0.80	
Accuracy					
			[°]	-10 ... 10	
Absolute positioning					
				1 revolution	
Max. speed					
	n_{max}		[r/min]	8000	
Max. input voltage					
DC	$U_{in,max}$		[V]	10.0	
Max. input frequency					
	$f_{in,max}$		[kHz]	4.00	
Ratio					
Stator / rotor			± 5 %	0.30	
Rotor impedance					
	Z_{ro}		[Ω]	51 + j90	
Stator impedance					
	Z_{so}		[Ω]	102 + j150	
Impedance					
	Z_{rs}		[Ω]	44 + j76	
Min. insulation resistance					
At DC 500 V	R		[MΩ]	10.0	
Number of pole pairs					
				1	
Max. angle error					
			[°]	-10 ... 10	
Inverter assignment					
				E84AVTC E94A ECS EVS93	

1) 6 - Product key > speed/angle sensor

Speed-dependent safety functions

Suitable for safety function				No	Yes
Max. permissible angular acceleration					
MCA10 ... MCA19 ²⁾	α		[rad/s ²]		22 000
MCA20 ... MCA26 ²⁾	α		[rad/s ²]		22 000
Functional safety					
IEC 61508					SIL3
EN 13849-1					Up to Performance Level e

2) 1 - Single encoder concepts with resolvers



Incremental encoder and SinCos absolute value encoder

Encoder type			TTL incremental		SinCos incremental	
Speed/angle sensor			T20	T40	S20	S15
Product key			IG2048-5V-T	IG4096-5V-T	IG2048-5V-S	IG1024-5V-V3
Encoder type			Single-turn			
Pulses			2048	4096	2048	1024
Output signals			TTL		1 V _{ss}	
Interfaces			A, B, N track and inverted			
Absolute revolutions			0			
Resolution						
Angle ²⁾		[°]	2.60	1.30	0.40	
Accuracy		[°]	-2 ... 2		-0.8 ... 0.8	
Min. input voltage						
DC	U _{in,min}	[V]	4.75		4.50	4.75
Max. input voltage						
DC	U _{in,max}	[V]	5.25		5.50	5.25
Max. speed						
	n _{max}	[r/min]	8789		5273	8000
Max. current consumption						
	I _{max}	[A]	0.15		0.10	0.070
Limit frequency						
	f _{max}	[kHz]	300		180	200
Inverter assignment			E84AVTC E94A ECS EVS93			E94A

¹⁾ 6 - Product key > speed/angle sensor

²⁾ Inverter-dependent.



Speed-dependent safety functions

Suitable for safety function			No	No	No	Yes
Max. permissible angular acceleration						
MQA20 ... MQA26	α	[rad/s ²]				73 000
Functional safety						
IEC 61508						SIL3
EN 13849-1						Up to Performance Level e



Incremental encoder and SinCos absolute value encoder

Encoder type			SinCos absolute value				
Speed/angle sensor			EQI	SRS	SRM	ECN	EQN
Product key			AM32-5V-E	AS1024-8V-H	AM1024-8V-H	AS2048-5V-E	AM2048-5V-E
Encoder type			Multi-turn	Single-turn	Multi-turn	Single-turn	Multi-turn
Pulses			32	1024		2048	
Output signals			1 Vss				
Interfaces			EnDat	Hiperface		EnDat	
Absolute revolutions			4096	1	4096	1	4096
Resolution							
Angle		[°]	0.40				
Accuracy							
		[°]	-5 ... 5	-0.8 ... 0.8		-0.6 ... 0.6	
Min. input voltage							
DC	$U_{in,min}$	[V]	4.75	7.00		4.75	
Max. input voltage							
DC	$U_{in,max}$	[V]	5.25	12.0		5.25	
Max. speed							
	n_{max}	[r/min]	12000	6000		12000	
Max. current consumption							
	I_{max}	[A]	0.17	0.080		0.15	0.25
Limit frequency							
	f_{max}	[kHz]	6.00	200			
Inverter assignment							
			E94A	E84AVTC E94A ECS EVS93		E94A	

1)   6 - Product key > speed/angle sensor

MCA asynchronous servo motors

Accessories



Blowers

Rated data for 50 Hz

		Enclosure	Number of phases	U_{\min} [V]	U_{\max} [V]	$U_{N, AC}$ [V]	P_N [kW]	I_N [A]
MCA13	F10	IP54	1	210	240	230	0.019	0.12
MCA14							0.040	0.25
MCA17							0.17	0.73
MCA19							0.060	0.26
MCA20	F10 F1F	IP23s			250		0.24	1.05
MCA21	F10	IP54			240		0.40	1.75
MCA22	F10	IP23s			250			
MCA26	F1F	IP54						

Rated data for 60 Hz

		Enclosure	Number of phases	U_{\min} [V]	U_{\max} [V]	$U_{N, AC}$ [V]	P_N [kW]	I_N [A]
MCA13	F10	IP54	1	210	240	230	0.019	0.12
MCA14							0.040	0.25
MCA17							0.20	0.90
MCA19							0.060	0.26
MCA20	F10 F1F	IP23s			250		0.28	1.23
MCA21	F10	IP54			240		0.41	1.82
MCA22	F10	IP23s			250			
MCA26	F1F	IP54						



Temperature monitoring

The thermal sensors (1x KTY 83-110) used continuously monitor the motor temperature. The temperature signal is transmitted over the system cable of the feedback system to the servo controller. This means that the temperature of the motor is determined with great accuracy in the permitted operating range and at the same time the overtemperature response configured in the controller is executed in the event of overtemperature in one of the winding phases.

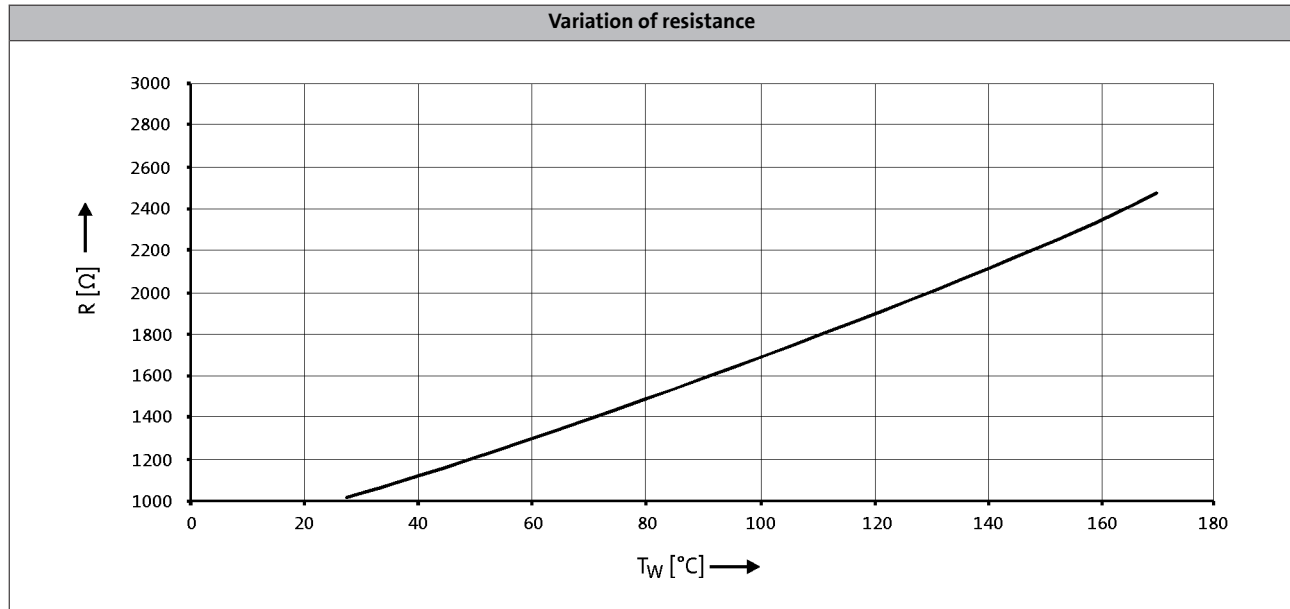

- ▶ If the detector is supplied with a measured current of 1 mA, the above relationship between the temperature and the resistance applies.

MCA asynchronous servo motors

Accessories



Terminal box

Motors MCA10 to 19/21

If a servo motor is to be connected to an existing cable or plug connectors are not to be used for other reasons, the connection can also be made via a terminal box.

The motor can either be fitted with a terminal box for the power connection and motor holding brake or a second terminal box provided to connect the motor feedback and blower (if applicable).

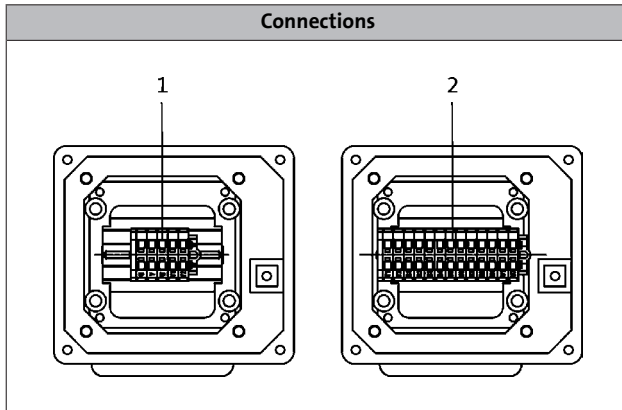

1: Power connection + brake connection + PE connection.

2: Angle/speed sensor connection + thermal sensor connection

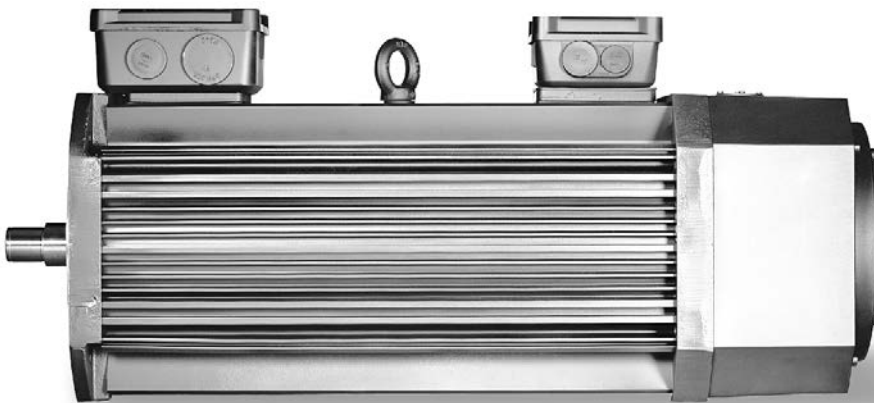

MCA asynchronous servo motors with blower and terminal box

MCA asynchronous servo motors

Accessories



Terminal box

Motors MCA10 to 19/21

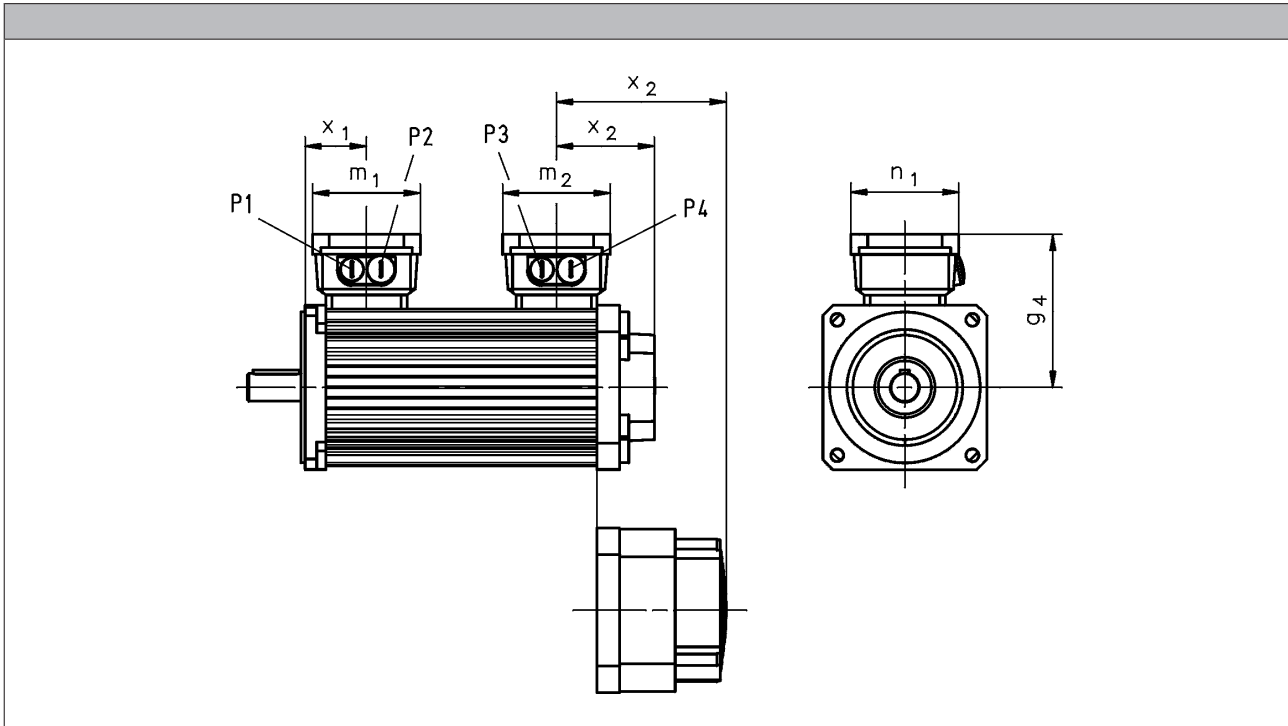

			MCA10I40	MCA13I41	MCA14L20	MCA17N23	MCA19S23	MCA21X25
					MCA14L41	MCA17N41	MCA19S42	MCA21X42
R□0 B0	x ₂	[mm]	78	77	85		93	97
R□0 P□	x ₂	[mm]	78	77	85		93	97
S□□ / E□□ / T20 / B0	x ₂	[mm]	132	131	140	139	143	147
S□□ / E□□ / T20 / P□	x ₂	[mm]	132	131	140	139	143	147

			MCA13I34	MCA14L16	MCA17N17	MCA19S17	MCA21X17
				MCA14L35	MCA17N35	MCA19S35	MCA21X35
R□0 B0	x ₂	[mm]	145	147	171	190	193
R□0 P□	x ₂	[mm]	145	147	171	190	193
S□□ / E□□ / T20 / B0	x ₂	[mm]	199	202	225	240	243
S□□ / E□□ / T20 / P□	x ₂	[mm]	199	202	225	240	243

- ▶ Speed/angle sensor: R50 / S□□ / E□□ / T20
- ▶ Brake: B0 / P□

	g ₄	m ₁	m ₂	n ₁	x ₁	P ₁	P ₂	P ₃	P ₄
	[mm]	[mm]	[mm]	[mm]	[mm]	[mm]	[mm]	[mm]	[mm]
MCA10	113	93	93	93	54	M20x1.5	M20x1.5	M20x1.5	M20x1.5
MCA13	125				57				
MCA14	133				53				
MCA17	141				55				
MCA19	158	115	115	115	64	M25x1.5	M32x1.5	M25x1.5	M20x1.5
MCA21	169				70				

6.11

MCA asynchronous servo motors



Accessories

ICN connector

Servo motors MCA10 to 21 provide ICN connectors as standard for electrical connection. Servo motors MCA22 and MCA26 provide a terminal box for electrical connection.

A connector is used for the connection of motor and brake. The connections to the feedback system/temperature monitoring and the blower each employ a separate connector.

The connectors can be rotated through 270° and are fitted with a bayonet catch for SpeedTec connectors. As the connector fixing is also compatible with conventional union nuts. Existing mating connectors can therefore still be used without difficulty.

Connection for power and brake

► MCA10 to 17

Pin assignment			
Contact	Designation	Meaning	
1	BD1	Holding brake +	
2	BD2	Holding brake -	
PE	PE	PE conductor	
4	U	Phase U power	
5	V	Phase V power	
6	W	Phase W power	

► MCA19 to 21

Pin assignment			
Contact	Designation	Meaning	
1		Not assigned	
2			
+	BD1	Holding brake +	
-	BD2	Holding brake -	
PE	PE	PE conductor	
U	U	Phase U power	
V	V	Phase V power	
W	W	Phase W power	

MCA asynchronous servo motors



Accessories

ICN connector

Feedback connection

► Resolver

Pin assignment		
Contact	Designation	Meaning
1	+Ref	Transformer windings
2	-Ref	
3	+VCC ETS	Supply: Electronic nameplate
4	+COS	Cosine stator windings
5	-COS	
6	+SIN	Sine stator windings
7	-SIN	
8		Not assigned
9		
10		
11	+KTY	KTY temperature sensor
12	-KTY	

► Hiperface incremental encoder and SinCos absolute value encoder

Pin assignment		
Contact	Designation	Meaning
1	B	Track B/+SIN
2	A ⁻	Track A inverse/-COS
3	A	Track A/+COS
4	+U _B	Supply +
5	GND	Mass
6	Z ⁻	Zero track inverse/-RS485
7	Z	Zero track/+RS485
8		Not assigned
9	B ⁻	Track B inverse/-SIN
10		Not assigned
11	+KTY	KTY temperature sensor
12	-KTY	



ICN connector

Feedback connection

- SinCos absolute value encoder with EnDat interface

Pin assignment		
Contact	Designation	Meaning
1	U _p sensor	Supply: UP sensor
2		Not assigned
3		
4	0 V sensor	Supply: 0 V sensor
5	+KTY	KTY temperature sensor
6	-KTY	
7	+U _B	Supply +
8	Cycle	EnDat interface cycle
9	Cycle ⁻	EnDat interface inverse cycle
10	GND	Mass
11	Shield	Encoder housing screen
12	B	Track B
13	B ⁻	Track B inverse/-SIN
14	Data	EnDat interface data
15	A	Track A
16	A ⁻	Track A inverse
17	Data ⁻	EnDat interface inverse data

Blower connection

Pin assignment		
Contact	Designation	Meaning
PE	PE	PE conductor
1	U1	Fan
2	U2	
3		Not assigned
4		
5		
6		

MCA asynchronous servo motors

Technical data



MCA asynchronous servo motors

Technical data



MCA asynchronous servo motors

Technical data



13449919

Lenze SE
Hans-Lenze-Straße 1
D-31855 Aenzen
Phone: +49 (0)5154 82-0
Telefax: +49 (0)5154 82 28 00

www.Lenze.com

Lenze